

Unit **1**

# Area and Surface Area

The area of a shape is the amount of space the shape covers. You know the names of many two-dimensional and three-dimensional shapes, and have calculated the areas of rectangles.

How can you use what you have learned to cover other two-dimensional shapes? And what does it mean to cover a three-dimensional shape?

## Essential Questions

- What does it mean for two shapes to have the same area?
- How are the areas of rectangles, parallelograms, and triangles related?
- How are the surface area of polyhedra and the area of polygons related?

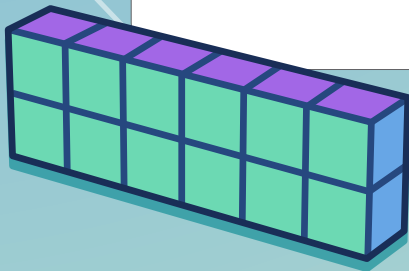
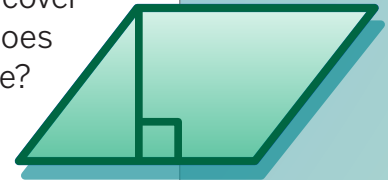
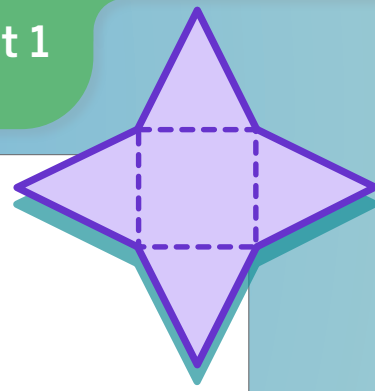

Area measures the space inside a two-dimensional figure and is expressed in square units.

Here are two possible strategies to determine the area of the same shape.

**Break the shape into non-overlapping rectangles and triangles.**

We can break this shape into a 2-by-3 rectangle, two unit squares, and two triangles to calculate an area of  $6 + 2 + 0.5 + 0.5 = 9$  square units.

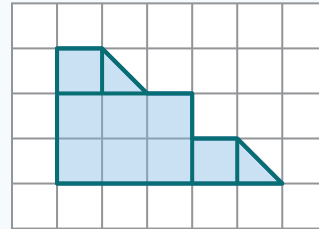

**Draw a rectangle around the shape and subtract the empty space.**

We can draw a 3-by-5 rectangle around this shape and subtract the empty squares to calculate an area of  $15 - 6 = 9$  square units.

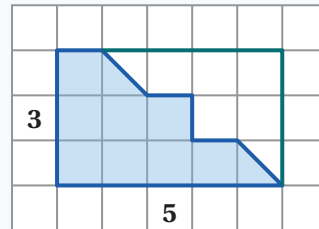

## Try This

Determine the area of the shape. Show or explain your thinking.

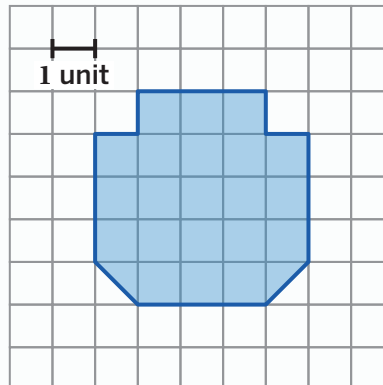

We can use shapes like rectangles, squares, and triangles to help us determine the area of more complex shapes. Here's how!

- *Decompose* the shape into two or more smaller shapes that have areas you know how to calculate.
- Add the smaller areas together.

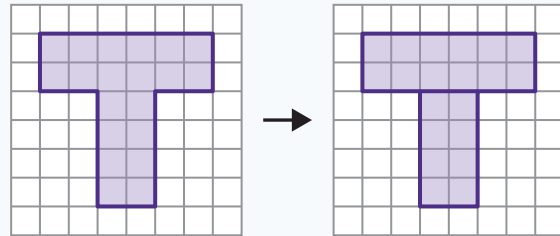

- Decompose the shape and *rearrange* the pieces to form one or more other shapes that have areas you know how to calculate.
- Calculate the area of the new, simpler shape(s).

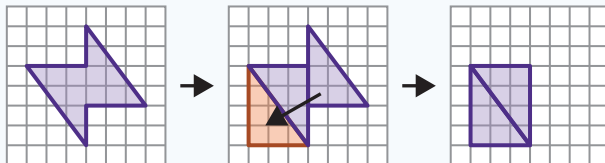

- If your shape has empty areas in it, determine its area as if it were a solid shape.
- Calculate the area of the empty space and subtract it from the total area.

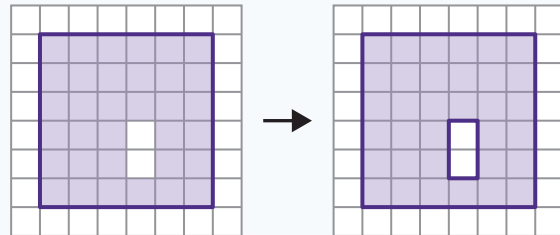

## Try This

Determine the area of the shape. Show or explain your thinking.

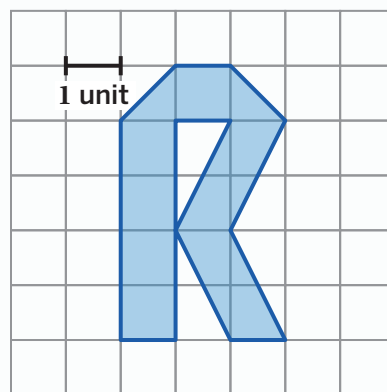

A *quadrilateral* is any shape that has four sides. A *parallelogram* is a type of quadrilateral that has two pairs of parallel sides, such as rectangles and squares.

We can use different strategies to determine the area of a parallelogram.

**Cut the parallelogram into two pieces** and rearrange the pieces to form a rectangle.

The parallelogram's area is equal to the area of the rectangle.

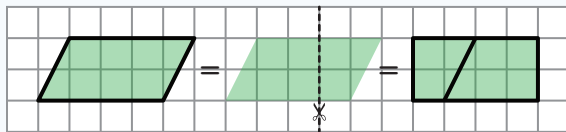

**Draw a rectangle around the parallelogram** so that it includes two right triangles. Rearrange the two triangles to form a smaller rectangle.

The parallelogram's area is equal to the difference between the areas of the larger rectangle and the smaller rectangle.

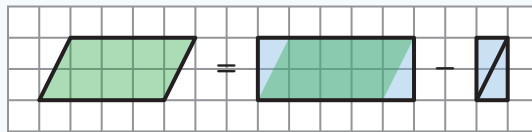

## Try This

Here are two parallelograms.

- Determine the area of parallelogram *A*.
- Determine the area of parallelogram *B*.

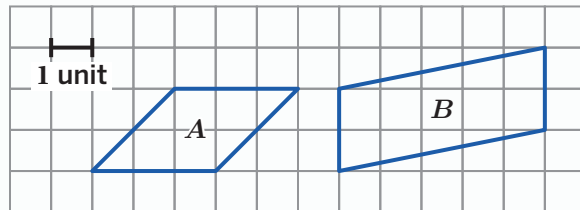

We can use a ruler to determine the lengths of the **base** and **height** of a parallelogram when it is not presented on a grid with lengths that we can count. No matter which side of a parallelogram you choose as the base, its area will be equal to the product of the length of the base and the length of its matching height.

Here's an example of the same parallelogram with different sides selected as the base and different points used to measure the height. Each set of measurements will produce the same area.

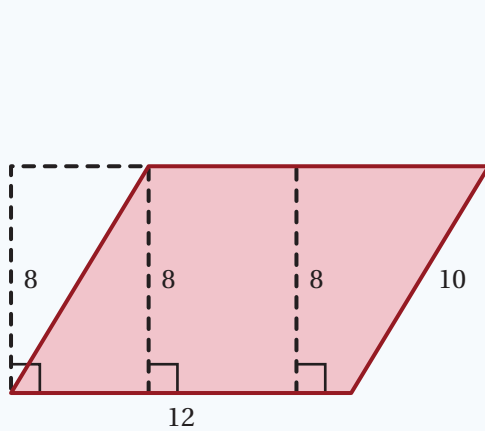

Area = base • height

$$A = 12 \cdot 8$$

$$A = 96 \text{ square units}$$

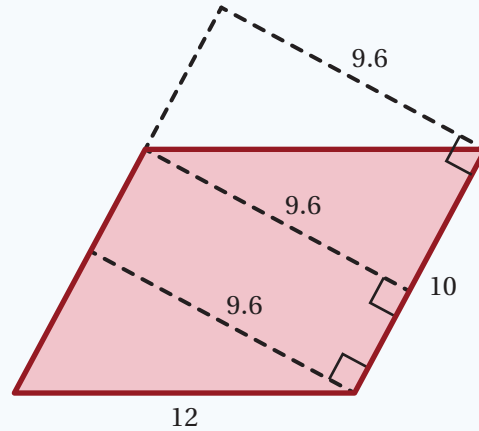

Area = base • height

$$A = 10 \cdot 9.6$$

$$A = 96 \text{ square units}$$

## Try This

Andrea and Elena are exploring this parallelogram.

- a** Andrea says that 9 inches is the base and 6 inches is the height. Elena says that 7.5 inches is the base and 7.2 inches is the height.

Who do you agree with? Explain your reasoning.

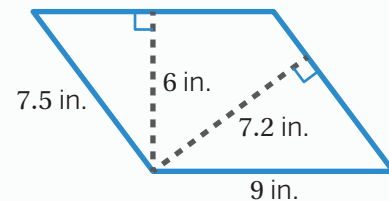

- b** Calculate the area of the parallelogram.

You can use what you know about the area of quadrilaterals to help you determine the area of triangles. Here are two ways of doing so using a grid.

**Strategy 1**

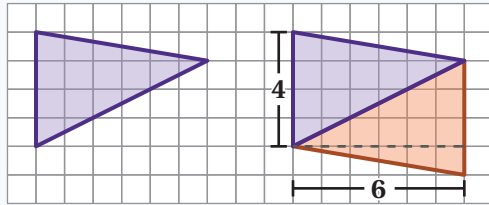

- Make a copy of the triangle and rearrange the two triangles to form a parallelogram.
- Determine the area of the parallelogram by multiplying its base by its height.  
 $4 \cdot 6 = 24$  square units
- The area of the triangle is half the area of the parallelogram.  $\frac{24}{2} = 12$  square units

**Strategy 2**

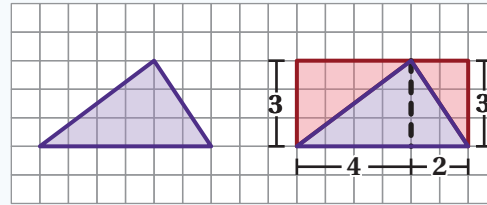

- Draw a rectangle around the triangle.
- Cut the rectangle into two smaller rectangles. This also cuts the triangle into two smaller triangles.
- Determine the area of each rectangle.  
 $4 \cdot 3 = 12$  square units  
 $2 \cdot 3 = 6$  square units
- The area of each triangle is half the area of its matching rectangle.  
 $\frac{12}{2} = 6$  square units  
 $\frac{6}{2} = 3$  square units
- Add the two smaller triangle areas together.  
 $6 + 3 = 9$  square units

**Try This**

Determine the area of this triangle. Show or explain your thinking.

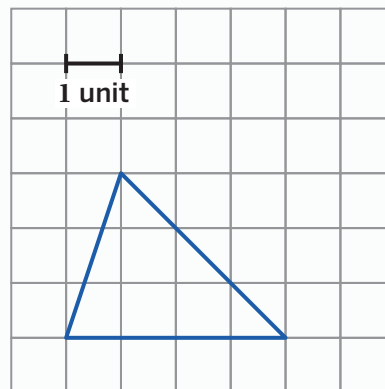

You can arrange two identical copies of any triangle to create a parallelogram with the same base and height measurements. This shows us that the area of a triangle is equal to half the area of its related parallelogram.

Here are two ways to form a parallelogram using two identical triangles with a base of 6 centimeters and a height of 5 centimeters.

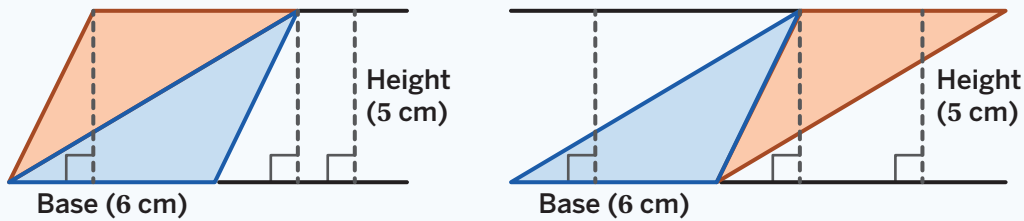

The area of the parallelogram is  $A = 6 \cdot 5 = 30$  square centimeters. Since the area of the triangle is half the area of the parallelogram, the area of the triangle is 15 square centimeters. In general, the formula for the area of a triangle is

$$\text{Area} = \frac{1}{2} \cdot \text{base} \cdot \text{height}.$$

### Try This

Here are three shapes. Fill in the table with the base, height, and area of each shape.

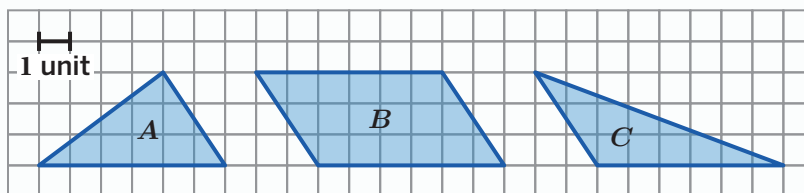

Shape	Base (units)	Height (units)	Area (sq. units)
<i>A</i>			
<i>B</i>			
<i>C</i>			

The area of any triangle is equal to half of the product of its base and height. You can select any side of the triangle to be the base. The height of a triangle is the *perpendicular* distance between a point on the base and the opposite corner of the triangle. The height is often shown with a dotted line.

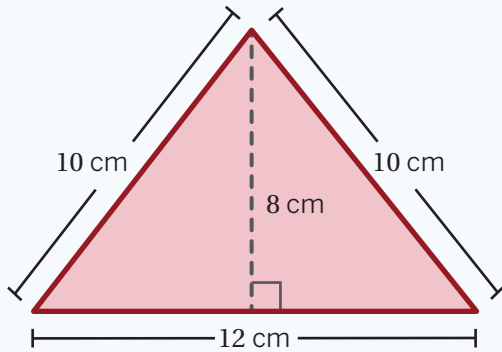

$$A = \frac{1}{2}bh$$

$$A = \frac{1}{2}(12)(8)$$

$$A = 48 \text{ square centimeters}$$

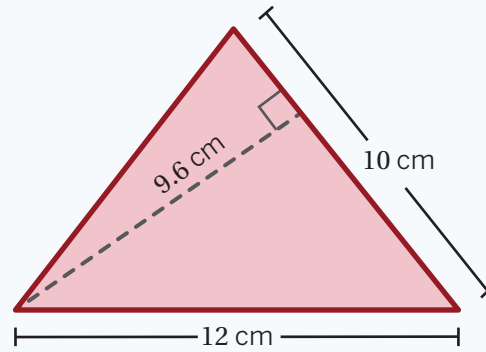

$$A = \frac{1}{2}bh$$

$$A = \frac{1}{2}(10)(9.6)$$

$$A = 48 \text{ square centimeters}$$

All sides of the triangle can be a base, but some base-height pairs are easier to measure and calculate with.

## Try This

Calculate the area of this triangle. Show or explain your thinking.

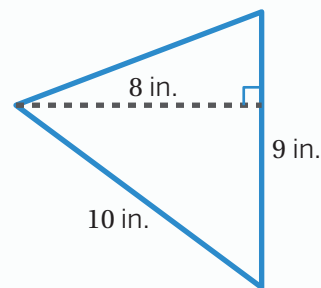

A **polygon** is a closed two-dimensional shape. For any polygon:

- The end of every side connects to the end of another side.
- All sides are straight, not curved.
- The sides do not cross each other.

You can use shapes that have areas you know how to calculate, like triangles and parallelograms, to help you determine the area of polygons.

Here are two ways a polygon can be cut into triangles and parallelograms to help determine its area.

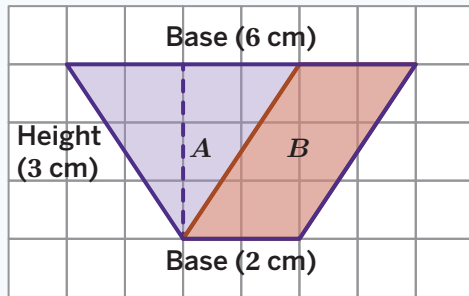

Area of  
Triangle *A*

$$A = \frac{1}{2} \cdot 4 \cdot 3$$

$$A = 6$$

Area of  
Parallelogram *B*

$$A = 2 \cdot 3$$

$$A = 6$$

$$\text{Area} = 6 + 6$$

$$\text{Area} = 12 \text{ square centimeters}$$

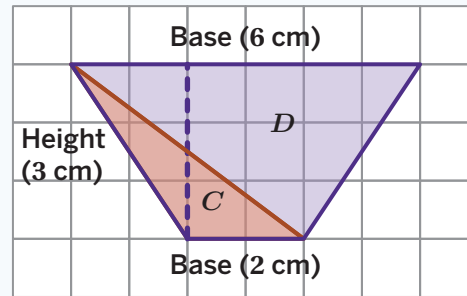

Area of  
Triangle *C*

$$A = \frac{1}{2} \cdot 2 \cdot 3$$

$$A = 3$$

Area of  
Triangle *D*

$$A = \frac{1}{2} \cdot 6 \cdot 3$$

$$A = 9$$

$$\text{Area} = 3 + 9$$

$$\text{Area} = 12 \text{ square centimeters}$$

## Try This

Calculate the area of each polygon.

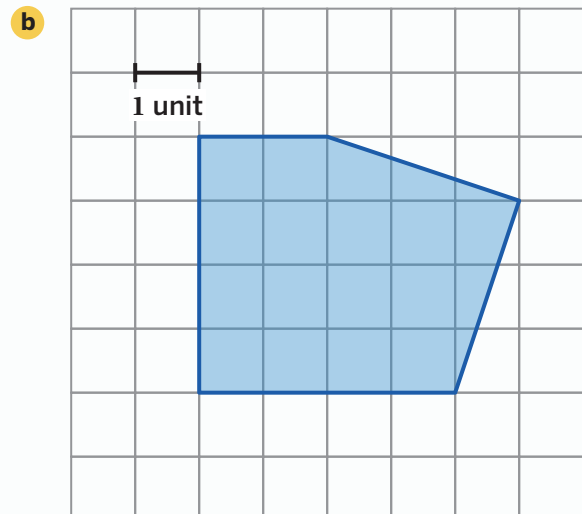
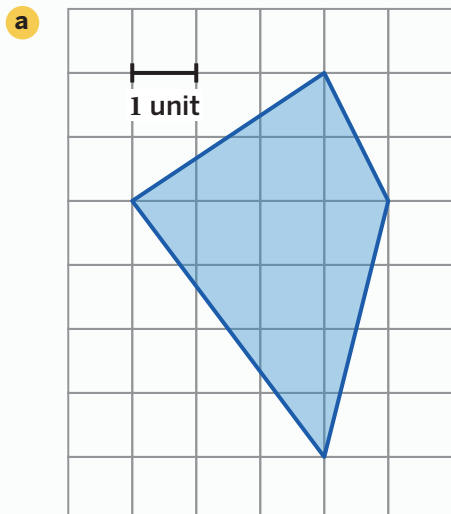

A **polyhedron** is a closed three-dimensional shape with flat sides. When we have more than one polyhedron, we call them *polyhedra*. Each flat side of a polyhedron is called a **face**, and the face that gives the polyhedron its name is called the **base**.

Prisms and pyramids are types of polyhedra.

A **prism** is a polyhedron that has two bases that are identical copies. The bases are connected by rectangles or parallelograms.

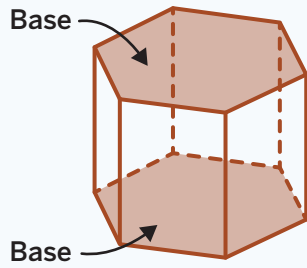

Prism

A **pyramid** is a polyhedron in which the base is a polygon. All the other faces are triangles that meet at a single point.

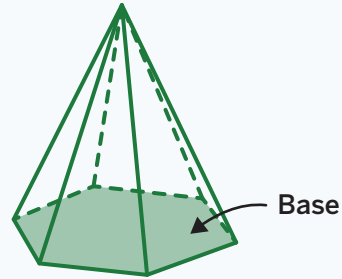

Pyramid

A **net** is a two-dimensional figure that can be folded to make a polyhedron. Nets show us what a polyhedron would look like if it was “unfolded” and allow us to see each face at the same time.

## Try This

If this net were folded, would it make a pyramid, prism, or neither?

Explain your thinking.

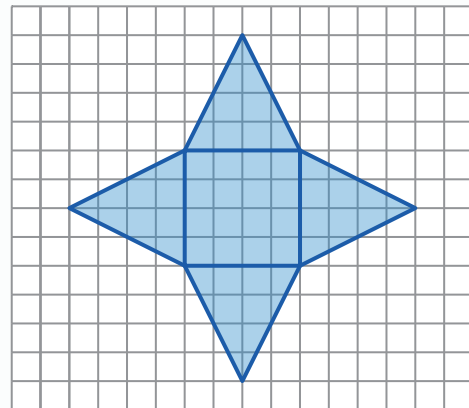

We can draw a net to create a two-dimensional representation of a three-dimensional figure. A net can help us determine the **surface area** of a polyhedron because it shows every face at once.

Here are some examples of how to use a net to determine the surface area of a pyramid or a prism.

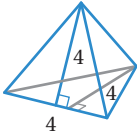
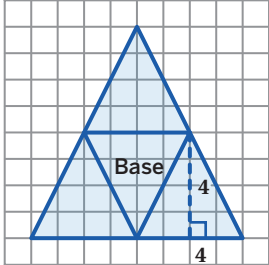
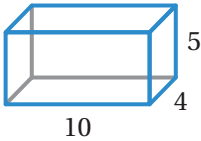
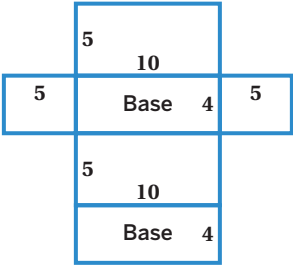
Polyhedron	Net	Surface Area
<p><b>Triangular pyramid</b></p> 		$4\left(\frac{1}{2} \cdot 4 \cdot 4\right) = 32 \text{ square units}$
<p><b>Rectangular prism</b></p> 		$2(4 \cdot 10) + 2(4 \cdot 5) + 2(5 \cdot 10) = 220 \text{ square units}$

## Try This

Here is a net.

- What polyhedron will this net create when folded?
- What is its surface area?

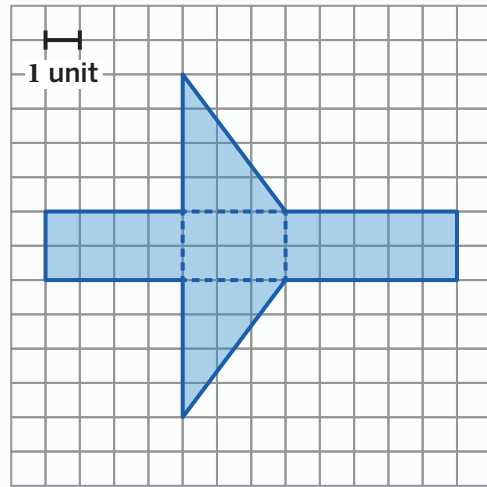

The surface area of any polyhedron is the total area of all the faces. Drawing a net or sketching individual faces can help us make sense of and keep track of calculations.

We can group identical faces together to reduce the number of steps in our calculations. For example, a cube is made of 6 identical faces, so we can determine the area of one face and multiply by 6 to determine the total surface area.

Here's an example.

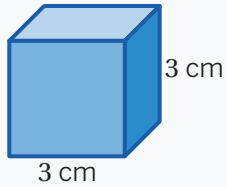

**One Face**

$$3 \cdot 3 = 9$$

**All Faces**

$$9 \cdot 6 = 54$$

**Surface Area**

54 square centimeters

## Try This

Here is a rectangular pyramid and its net.

- a** Label the net with the measurements of each face.

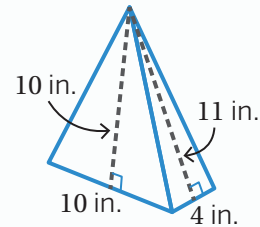

- b** Calculate the surface area.

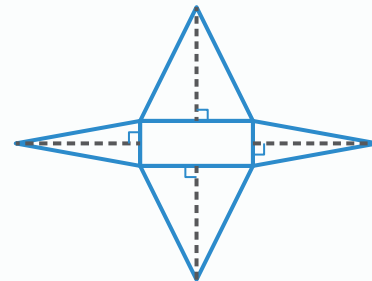

To-go containers and reusable plastic food containers are examples of polyhedra that we see in everyday life.

Mathematical modeling can help us design everyday objects, such as to-go containers. To do this, we need to:

- Know the size and shape of the food item that will be placed in the container.
- Decide on the shape of the container.
- Make sure that the container will be big enough to hold the food item, without being too big.
- Know how much material we need to make the container. That's where surface area comes in handy!

### Try This

Here is a design for a possible to-go container.

- Describe a food that might fit in this container.
- Calculate how much material you would need to make the container.

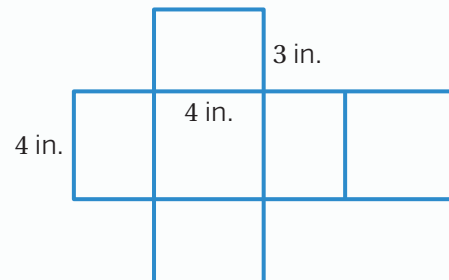

## Lesson 1

22 square units

*Caregiver Note: Here are two strategies for determining the area:*

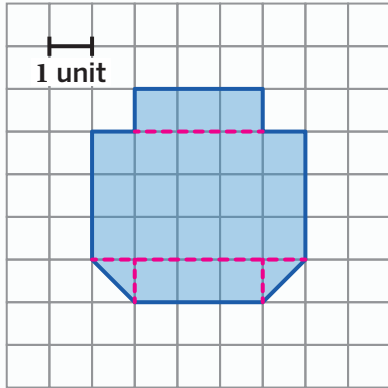

$$3 + 3 + 0.5 + 0.5 + 15 = 22 \text{ square units}$$

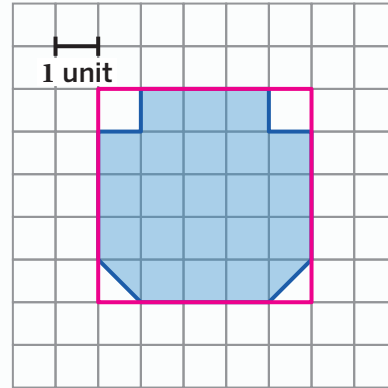

$$5 \cdot 5 - (2 \cdot 1 + 2 \cdot 0.5) = 22 \text{ square units}$$

## Lesson 2

10 square units

*Caregiver Note: Here are two strategies for determining the area:*

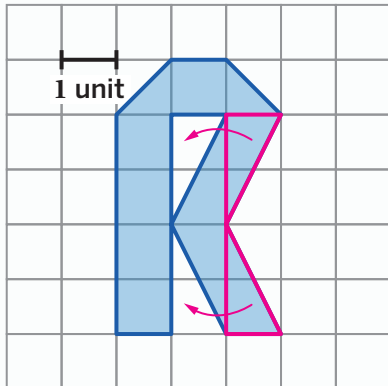

Count all of the whole squares (5) and half squares ( $0.5 + 0.5$ ). Then move the two triangles on the right over to create two rectangles that each have an area of 2 square units. When you add these, the area is  $5 + 0.5 + 0.5 + 2 + 2 = 10$  square units.

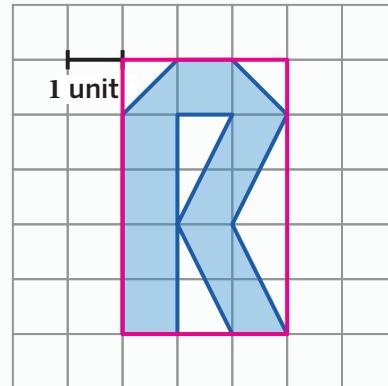

Draw a box around the shape and calculate the area, which is  $5 \cdot 3 = 15$  square units. Then subtract the area of the unshaded parts from this area;  $15 - 5 = 10$  square units.

## Lesson 3

- a** 6 square units

*Caregiver Note: One strategy is to draw a rectangle around the parallelogram and find its area, which is 10 square units. Then, subtract the areas of the pieces inside the rectangle that are not part of the parallelogram to get  $10 - 4 = 6$  square units.*

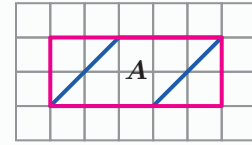

- b** 10 square units

*Caregiver Note: One strategy is to move the triangle at the bottom up to create a rectangle, then calculate the area of the rectangle. The area of the rectangle is  $2 \cdot 5 = 10$  square units.*

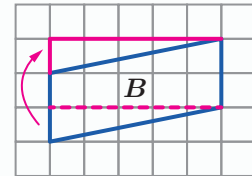

## Lesson 4

- a** Responses vary. Andrea and Elena are both correct. They picked different sides as the base of the parallelogram, but each chose a height that is perpendicular to the base they chose.

- b** 54 square inches

*Caregiver Note: Using Andrea's base and height,  $9 \cdot 6 = 54$ . Using Elena's base and height,  $7.5 \cdot 7.2 = 54$ .*

## Lesson 5

6 square units

*Caregiver Note: Here are two strategies for determining the area:*

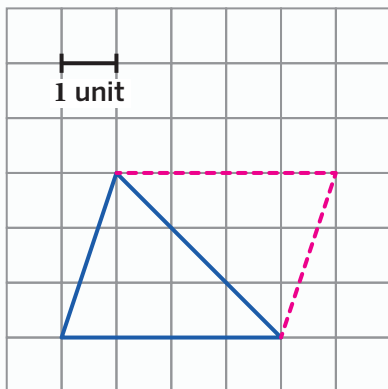

*Create a parallelogram with the same base and height as the triangle. The area of this parallelogram is  $3 \cdot 4 = 12$  square units. The area of the triangle is half as much, 6 square units.*

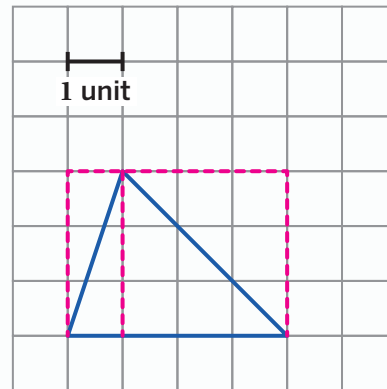

*Split the triangle into two triangles so that each is half of a rectangle. The area of the original triangle is  $\frac{1 \cdot 3}{2} + \frac{3 \cdot 3}{2}$ , or  $1.5 + 4.5 = 6$  square units.*

### Lesson 6

Shape	Base (units)	Height (units)	Area (sq. units)
A	6	3	9
B	6	3	18
C	6	3	9

### Lesson 7

36 square units

Caregiver Note: First, multiply  $9 \cdot 8 = 72$ . Then,  $\frac{72}{2} = 36$ .

### Lesson 8

a 12 square units

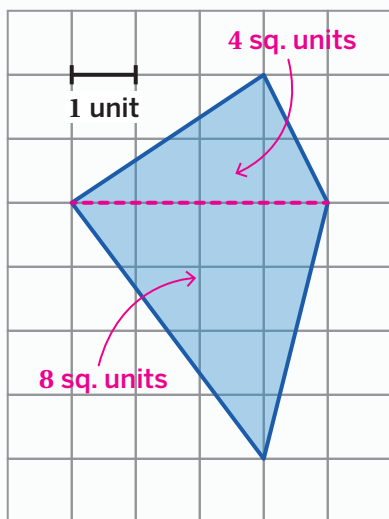

Caregiver Note: One strategy is to break the shape into two triangles and find the area of each. Then add these areas, so  $4 + 8 = 12$  square units.

b 17 square units

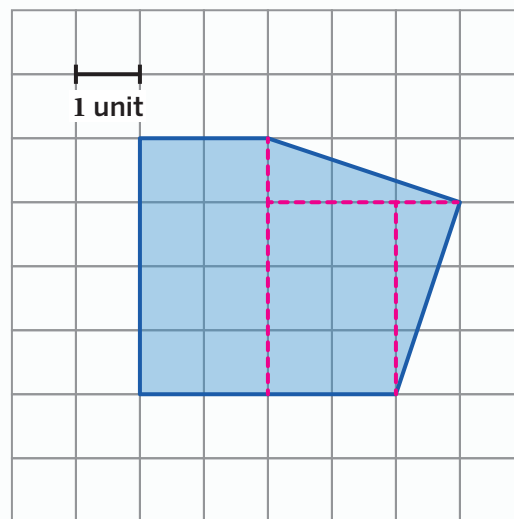

Caregiver Note: We can break the shape into two rectangles and two triangles and find the area of each shape. Then add all the areas, so  $8 + 6 + 1.5 + 1.5 = 17$  square units.

### Lesson 9

Pyramid

Caregiver Note: The net has one base. All the other faces are triangles that would meet at a vertex if it were folded.

## Lesson 10

- a Triangular prism

*Caregiver Note: The net shows two triangular faces that are identical copies. Those are the two bases of the prism, and all the other faces are rectangles.*

- b 36 square units

*Caregiver Note: One strategy is to add the areas of each face. The three rectangles have areas of 8, 6, and 10 square units. Each triangle has an area of 6 square units. Together the sum of the areas is  $8 + 6 + 10 + 6 + 6 = 36$  square units.*

## Lesson 11

- a

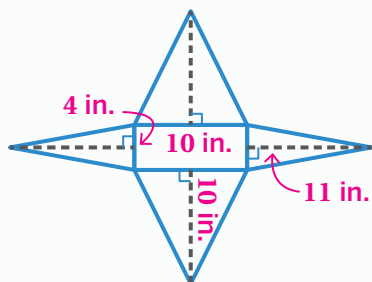

- b 184 square inches

*Caregiver Note: One strategy is to add the areas of each face. The base has an area of  $10 \cdot 4 = 40$  square inches. There are two triangular faces with an area of  $\frac{10 \cdot 10}{2} = 50$  square inches and two triangular faces with an area of  $\frac{11 \cdot 4}{2} = 22$  square inches. Altogether,  $40 + 2 \cdot 50 + 2 \cdot 22 = 184$  square inches.*

## Lesson 12

- a Responses vary. A hamburger might fit in this box.

- b 80 square inches of material

*Caregiver Note: This is the same as calculating surface area. There are two faces that are  $4 \cdot 4 = 16$  square inches and four faces that are  $3 \cdot 4 = 12$  square inches, and  $2 \cdot 16 + 4 \cdot 12 = 80$  square inches.*