

Amplify Desmos Math **CALIFORNIA**

Kindergarten

**Intervention, Extension, and
Investigation Resources**

Contents



Mini-Lessons

Log in to the digital curriculum to review all program Mini-Lessons, Extensions, and Investigations.

Unit 1: Math in Our World 3

| | | |
|------|---|----|
| 1.07 | Matching Representations of the Same Quantity | 4 |
| 1.08 | Identifying Equal Groups | 8 |
| 1.09 | Showing the Same Number in Different Ways | 12 |
| 1.10 | Using Fingers or Drawings to Show a Number | 16 |
| 1.11 | Answering the Question "Are There Enough?" | 20 |
| 1.12 | Matching to Create Groups With Enough Objects | 24 |
| 1.13 | Counting to Determine the Quantity of a Group | 28 |
| 1.14 | Exploring How Many Are in a Group | 32 |
| 1.15 | Exploring Counting Strategies | 36 |
| 1.16 | Counting With Math Tools | 40 |
| 1.17 | Representing Quantities Using Drawings | 44 |
| 1.18 | Asking and Answering "How Many?" Questions | 48 |

Unit 2: Numbers 1–10 53

| | | |
|------|---|-----|
| 2.02 | Representing Numbers With Fingers | 54 |
| 2.03 | Counting the Same Objects in Different Arrangements | 58 |
| 2.04 | Exploring Different Ways to Compare Groups of Objects | 62 |
| 2.05 | Reasoning About Groups With <i>More</i> , <i>Fewer</i> , or the <i>Same</i> Number of Objects | 66 |
| 2.06 | Comparing Objects Using <i>More</i> , <i>Fewer</i> , and the <i>Same</i> | 70 |
| 2.07 | Counting Objects in Scattered Arrangements | 74 |
| 2.08 | Using Matching to Compare | 78 |
| 2.09 | Comparing Two Groups of Objects Within 10 | 82 |
| 2.10 | Identifying Groups That Show <i>More</i> or <i>Fewer</i> | 86 |
| 2.11 | Drawing Groups With <i>More</i> , <i>Fewer</i> , or the <i>Same</i> | 90 |
| 2.12 | Writing a Number to Show How Many | 94 |
| 2.13 | Matching Numbers to Groups of Objects | 98 |
| 2.14 | Counting Out Objects to Represent Numbers | 102 |
| 2.15 | Drawing Objects to Represent a Written Number | 106 |
| 2.16 | Writing Numbers to Represent a Quantity | 110 |
| 2.17 | Ordering the Numbers 1–10 | 114 |
| 2.18 | Finding 1 <i>More</i> and 1 <i>Less</i> Than a Given Number | 118 |
| 2.19 | Representing Numbers 1-10 in Different Ways | 122 |
| 2.20 | Comparing Written Numbers and Groups of Objects | 126 |
| 2.21 | Comparing Two Written Numbers | 130 |
| 2.22 | Writing and Comparing Numbers | 134 |

Unit 3: Flat Shapes All Around Us 139

| | | |
|------|--|-----|
| 3.02 | Describing Shapes | 140 |
| 3.03 | Matching Shapes | 144 |
| 3.04 | Comparing Shapes | 148 |
| 3.05 | Sorting Shapes Into Categories | 152 |
| 3.06 | Identifying Circles and Triangles | 156 |
| 3.07 | Identifying and Comparing Rectangles | 160 |
| 3.08 | Using Longer and Shorter to Compare Lengths | 164 |
| 3.09 | Sorting Shapes Into Subcategories | 168 |
| 3.10 | Drawing Shapes | 172 |
| 3.11 | Describing and Naming Shapes | 176 |
| 3.12 | Putting Shapes Together to Form Larger Shapes | 180 |
| 3.13 | Sliding, Turning, and Flipping Shapes to Match Exactly | 184 |
| 3.14 | Forming Larger Shapes in Different Ways | 188 |
| 3.15 | Describing the Position of Shapes | 192 |
| 3.16 | Drawing Simple Shapes to Form Larger Shapes | 196 |

Unit 4: Understanding Addition and Subtraction 201

| | | |
|------|--|-----|
| 4.02 | Counting to Find the Total Number of Objects in Two Groups | 202 |
| 4.03 | Counting to Find the Total Number of Pictures | 206 |
| 4.04 | Counting Organized and Scattered Groups | 210 |
| 4.05 | Representing Addition With Objects | 214 |
| 4.06 | Representing Subtraction With Objects | 218 |
| 4.07 | Adding and Subtracting in the Real World | 222 |
| 4.08 | Telling and Acting Out Math Stories | 226 |
| 4.09 | Representing Math Stories With Objects | 230 |
| 4.10 | Solving Addition Story Problems | 234 |
| 4.11 | Solving Subtraction Story Problems | 238 |
| 4.12 | Representing a Story Problem With Drawings | 242 |
| 4.13 | Drawing to Show Story Problems With Zero | 246 |
| 4.14 | Creating and Solving Addition and Subtraction Story Problems | 250 |
| 4.15 | Introducing Expressions | 254 |
| 4.16 | Representing Story Problems With Expressions | 258 |
| 4.17 | Connecting Expressions and Drawings | 262 |
| 4.18 | Determining the Value of Expressions | 266 |
| 4.19 | Adding and Subtracting 0 and 1 | 270 |
| 4.20 | Writing Expressions to Represent Story Problems | 274 |

Mini-Lessons (continued)

Unit 5: Make and Break Apart Numbers Within 10 279

| | | |
|------|--|-----|
| 5.02 | Putting Together and Breaking Apart Numbers | 280 |
| 5.03 | Breaking Numbers Apart in More Than One Way | 284 |
| 5.04 | Matching Equations and Drawings | 288 |
| 5.05 | Breaking Apart Numbers in Many Ways | 292 |
| 5.06 | Making Sense of Math Stories | 296 |
| 5.07 | Solving and Writing Equations for Story Problems | 300 |
| 5.08 | Finding More Than One Answer to a Story Problem | 304 |
| 5.09 | Representing and Solving Story Problems | 308 |
| 5.10 | Writing Equations to Represent Story Problems | 312 |
| 5.11 | Showing Numbers on a 10-Frame | 316 |
| 5.12 | Breaking Apart 10 | 320 |
| 5.13 | Finding Number Pairs That Make 10 | 324 |
| 5.14 | Writing Equations to Make 10 | 328 |
| 5.15 | Breaking Apart 10 in More Than One Way | 332 |

Unit 6: Numbers 0–20 337

| | | |
|------|---|-----|
| 6.02 | Counting Larger Groups of Objects | 338 |
| 6.03 | Finding How Many When Objects are Rearranged | 342 |
| 6.04 | Showing Teen Numbers on Fingers and 10-frames | 346 |
| 6.05 | Matching Fingers and 10-Frames to Written Numbers | 350 |
| 6.06 | Counting Larger Groups of Images | 354 |
| 6.07 | Making Teen Numbers with 10 and Some Ones | 358 |
| 6.08 | Breaking Apart Teen Numbers Into 10 and Some Ones | 362 |
| 6.09 | Matching Teen Numbers on 10-Frames to Expressions | 366 |
| 6.10 | Writing Equations to Show Teen Numbers | 370 |
| 6.11 | Writing Numbers 0-20 | 374 |

| | |
|--|------------|
| Unit 7: Solid Shapes All Around Us | 379 |
| 7.02 Matching Solid Shapes to Real World Objects | 380 |
| 7.03 Comparing Objects Using <i>Heavier</i> and <i>Lighter</i> | 384 |
| 7.04 Comparing Objects Using <i>More</i> and <i>Less</i> | 388 |
| 7.05 Exploring How Solid Shapes Are Alike or Different | 392 |
| 7.06 Identifying Solid Shapes | 396 |
| 7.07 Building Real-World Objects Using Solid Shapes | 400 |
| 7.08 Building Solid Shapes | 404 |
| 7.09 Making Numbers Within 5 | 408 |
| 7.10 Counting Solid Shapes | 412 |
| 7.11 Comparing Groups of Shapes | 416 |
| 7.12 Making 10 in Different Ways | 420 |
| 7.13 Matching Equations to Shapes | 424 |
| 7.14 Solving Problems and Selecting Matching Equations | 428 |
| 7.15 Solving Subtraction Problems | 432 |
| 7.16 Solving Story Problems and Writing Equations to Match | 436 |



Unit 1 Math in Our World

| | |
|---|-----|
| Sub-Unit 1: Exploring Math Tools | 434 |
| Sub-Unit 2: Recognizing Quantities | 437 |
| Sub-Unit 3: Figuring Out How Many | 440 |

Unit 2 Numbers 1–10

| | |
|---|-----|
| Sub-Unit 1: Counting and Comparing Objects | 443 |
| Sub-Unit 2: Counting and Comparing Images | 447 |
| Sub-Unit 3: Connecting Quantities and Number | 450 |
| Sub-Unit 4: Comparing Numbers | 453 |

Unit 3 Flat Shapes All Around Us

| | |
|--|-----|
| Sub-Unit 1: Exploring Shapes in Our Community | 456 |
| Sub-Unit 2: Putting Shapes Together | 460 |

Unit 4 Understanding Addition and Subtraction

| | |
|--|-----|
| Sub-Unit 1: Counting to Add and Subtract | 465 |
| Sub-Unit 2: Representing and Solving Story Problems | 468 |
| Sub-Unit 3: Addition and Subtraction Expressions | 471 |

Extensions (continued)

Unit 5 Make and Break Apart Numbers Within 10

| | |
|--|-----|
| Sub-Unit 1: Making and Breaking Apart Numbers Within 9 | 475 |
| Sub-Unit 2: More Types of Story Problems | 479 |
| Sub-Unit 3: Making and Breaking Apart 10 | 482 |

Unit 6 Numbers 0–20

| | |
|---|-----|
| Sub-Unit 1: Counting Teen Numbers | 487 |
| Sub-Unit 2: 10 Ones and Some More | 490 |

Unit 7 Solid Shapes All Around Us

| | |
|--|-----|
| Sub-Unit 1: Exploring Solid Shapes | 495 |
| Sub-Unit 2: Adding and Subtracting With Shapes | 498 |



Investigations

| | |
|--------------------------------------|-----|
| Course Investigations | 501 |
| Investigation 1: 2D Shape Town | 502 |
| Investigation 2: Counting Book | 514 |
| Investigation Answer Keys | 529 |



Mini-Lessons

Unit 1

Mini-Lessons

Matching Representations of the Same Quantity

ML 1.07



Modeled Review



Guided Practice



Draw lines to match the fingers with the dots that show the same number.

1.

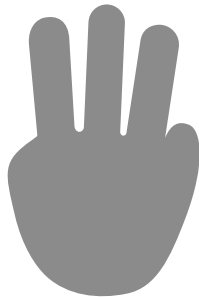

2.





Guided Practice



Circle the dots in each row that show the same number as the fingers.

3.

| | | |
|--|--|--|
| | | |
|--|--|--|

4.

| | | |
|--|--|--|
| | | |
|--|--|--|

Circle the two groups of dots that show the same number as the fingers.

5.

| | | | |
|--|--|--|--|
| | | | |
|--|--|--|--|



Check



Circle the two groups of dots that show the same number as the fingers.

| | | | |
|--|--|--|--|
| | | | |
|--|--|--|--|

Identifying Equal Groups

ML 1.08



Modeled Review



How many do you see ?

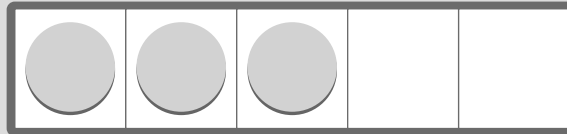

Santiago

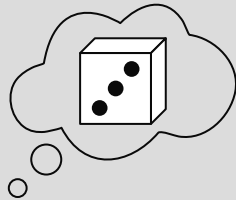

Diego



Guided Practice



1. Draw lines to match each 5-frame with the picture that shows the same number.

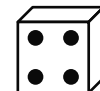









Guided Practice

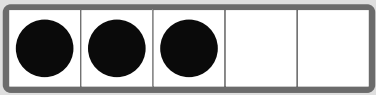

2. Circle the dots in each row that show the same number as the 5-frame.



| | |
|---|--|
|  |  |
|  |  |
|  |  |



Check

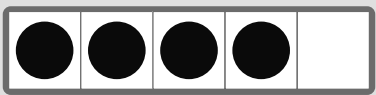

Circle the dots that show the same number as the 5-frame.

| | |
|---|--|
|  |  |
|---|--|

Showing the Same Number in Different Ways

ML 1.09



Modeled Review

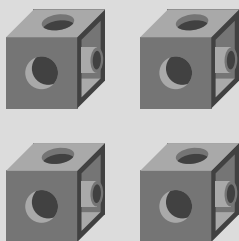

Guided Practice



1. Draw lines to match the groups that show the same number.

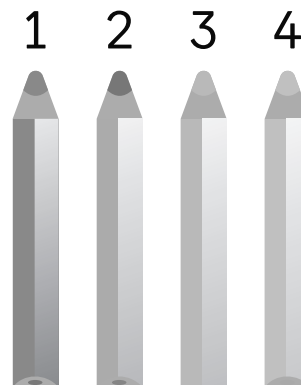
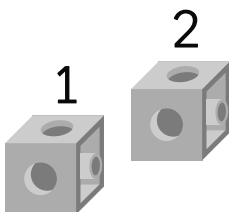
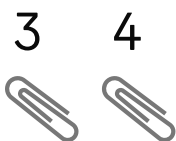
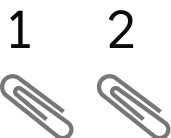



Guided Practice



2. Draw lines to match the cubes with the group of math tools that shows the same number.

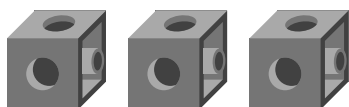
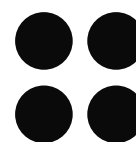
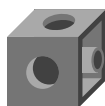
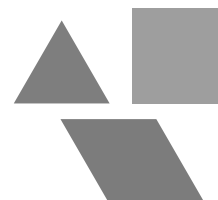
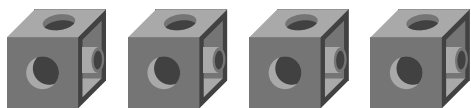

Check



Draw lines to match the dots with the group of math tools that shows the same number.

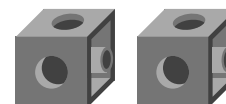
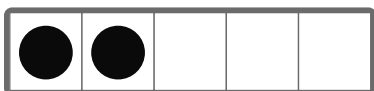

Using Fingers or Drawings to Show a Number

ML 1.10



Modeled Review



Name: Clare

Draw a group that shows the same number as the fingers.

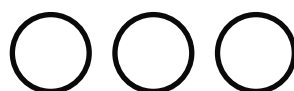

Guided Practice



Draw lines to match the fingers with the group that shows the same number.

1. 1 2



2. 2 3 4

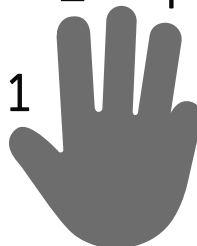



Guided Practice



Draw a group that shows the same number as the fingers.

3.



4.

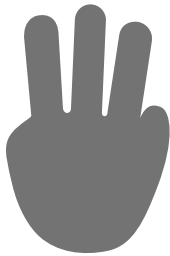

5.



Check



Draw a group that shows the same number as the fingers.

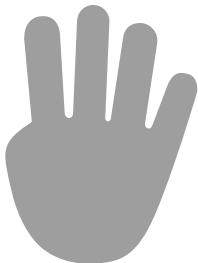

Answering the Question "Are There Enough?"

ML 1.11



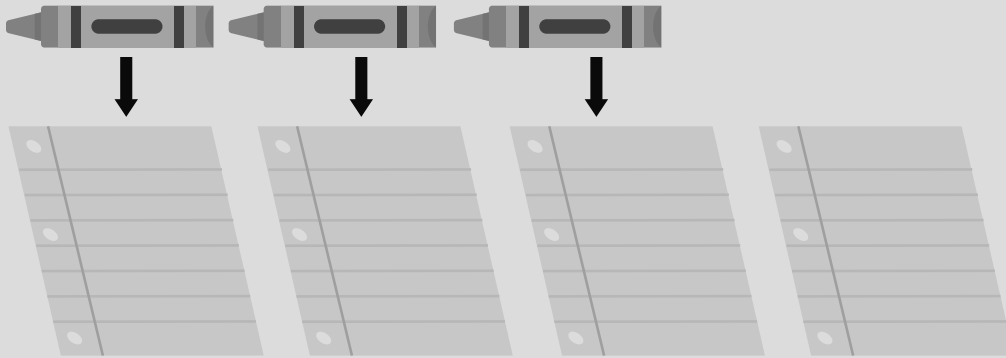

Modeled Review







Guided Practice





Are there enough bags?

1. 

2. 

3. 

4. 



Guided Practice



Are there enough baseballs? Circle  or .

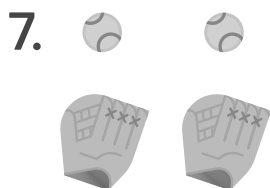
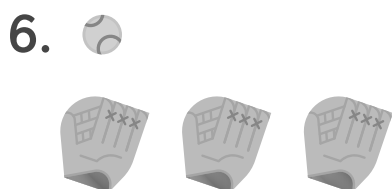
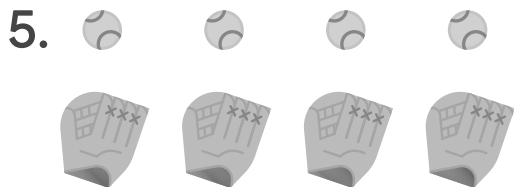

Check



Are there enough bags? Circle  or .



Matching to Create Groups With Enough Objects

ML 1.12



Modeled Review



Name: Diego

Draw enough hats so that each person in the group has one hat.

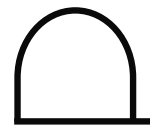
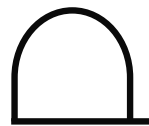
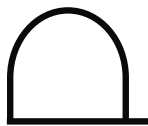
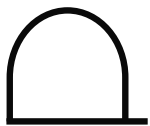
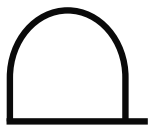

Guided Practice



Draw enough worms so that each bird has one worm.

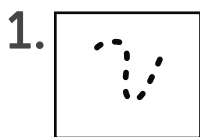



Guided Practice



Draw enough plates so that each banana has one plate.

4.

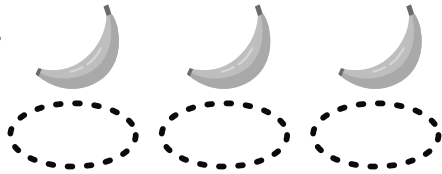

5.



6.



Check



Draw enough napkins so that each pretzel has one napkin.



Counting to Determine the Quantity of a Group

ML 1.13



Modeled Review



How many are there?

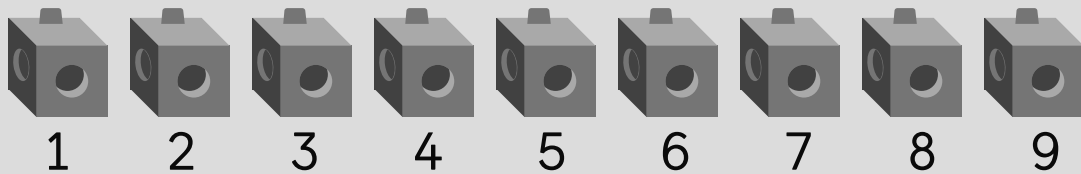

Guided Practice



How many are there?

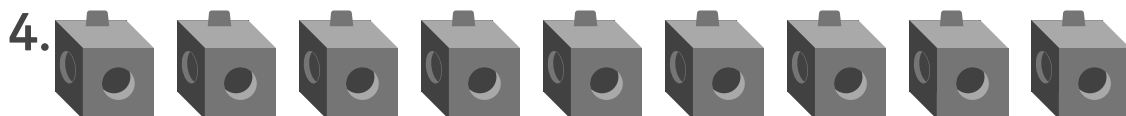
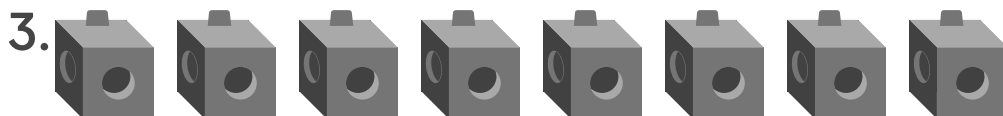
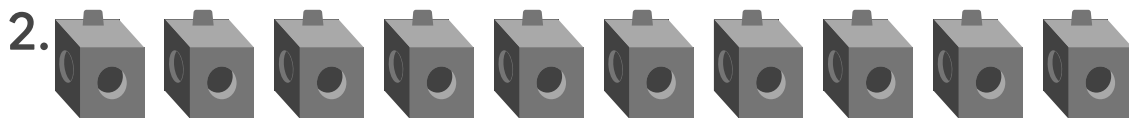
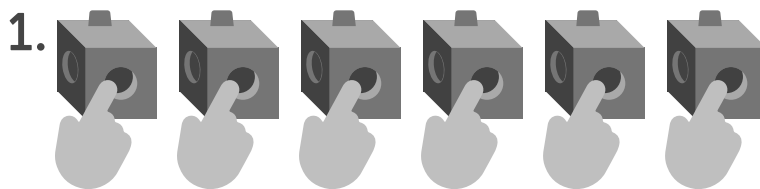



Guided Practice



How many are there?

5.

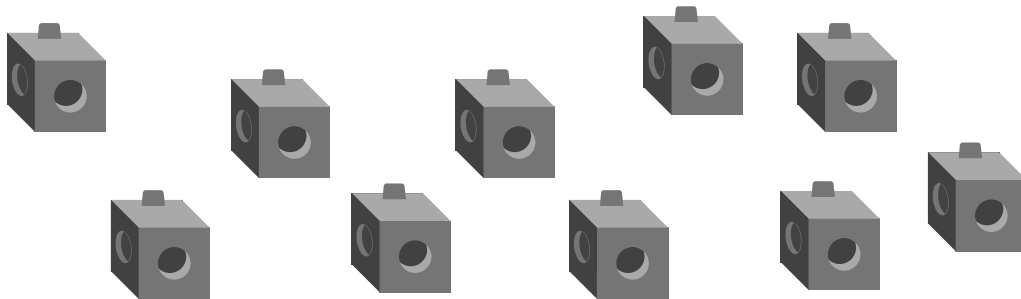

6.

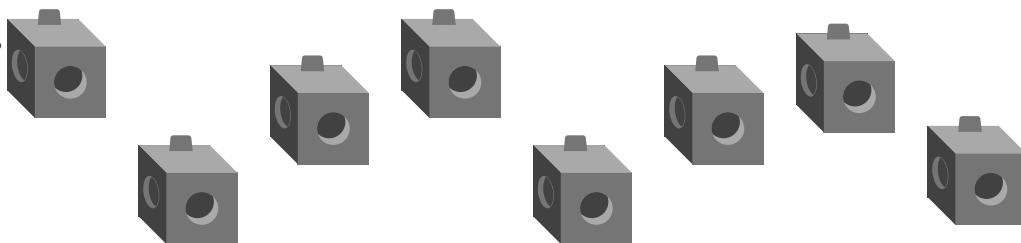

7.

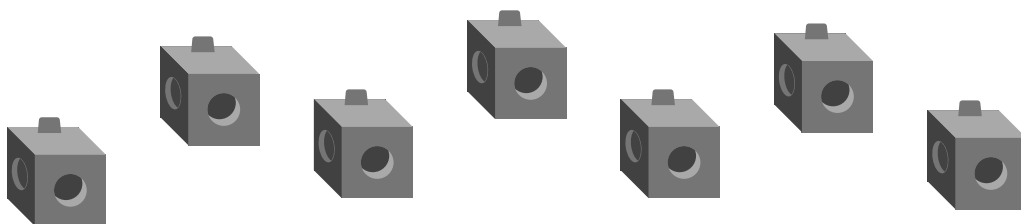

Check



How many are there?

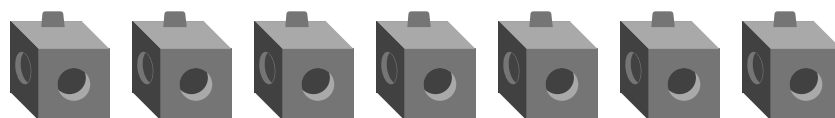

Exploring How Many Are in a Group

ML 1.14



Modeled Review



Name: Han

Touch and count the cubes. How many cubes are there?

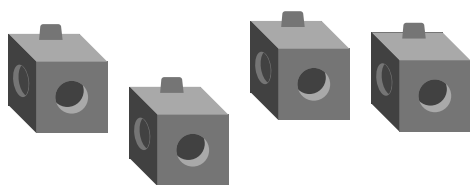

1, 2, 3, 4.
There are 4 cubes.



Guided Practice



How many cubes are there?

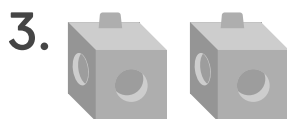
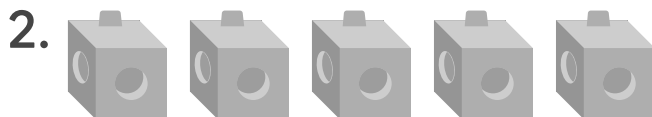
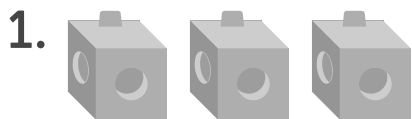



Guided Practice



How many cubes are there?

4.

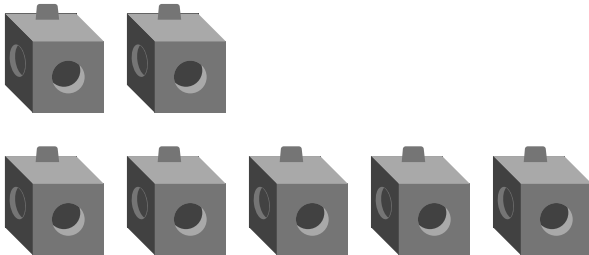

5.

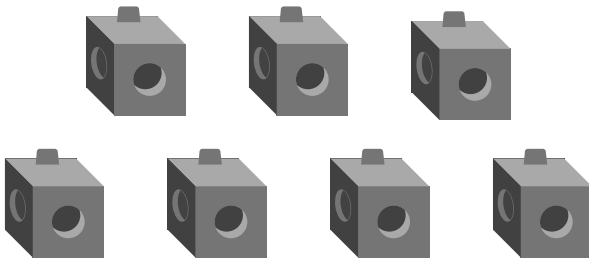

6.

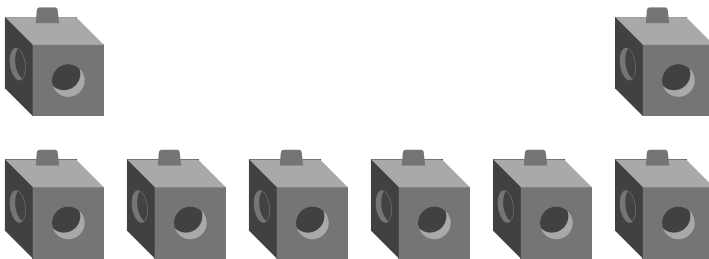

Check



How many cubes are there?

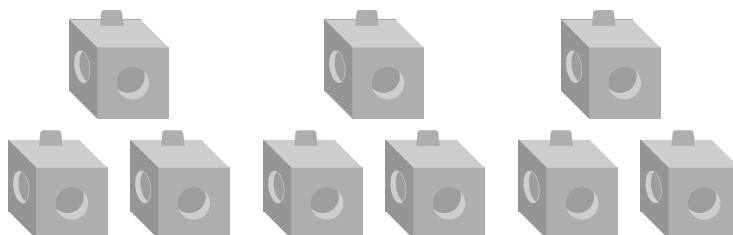

Exploring Counting Strategies

ML 1.15



Modeled Review



Put the counters in a line. Count to find how many.

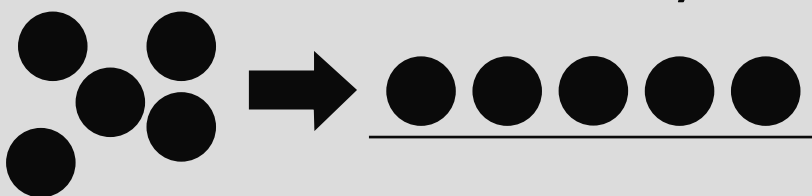

1, 2, 3, 4, 5.
There are 5
counters.



Guided Practice



Put the counters in a line. Count to find how many.

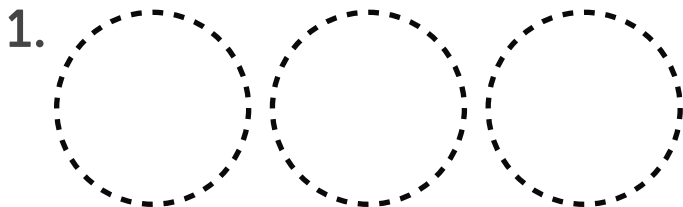

2.

3.



Guided Practice



Put the counters in a line. Count to find how many.

4.



5.



6.



7.



Check



Put the counters in a line. Count to find how many.



Counting With Math Tools

ML 1.16



Modeled Review



Move the counters to the 5-frame. Count to find how many.

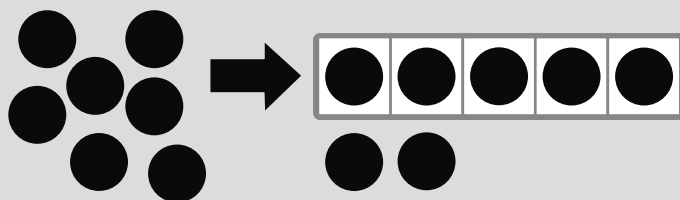

1, 2, 3, 4, 5, 6, 7.
There are 7
counters.



Guided Practice



Move the counters to the 5-frame. Count to find how many.

1.

| | | | | |
|--|--|--|--|--|
| | | | | |
|--|--|--|--|--|

2.

| | | | | |
|--|--|--|--|--|
| | | | | |
|--|--|--|--|--|



Guided Practice



3. Move the counters to the 5-frame. Count to find how many.

| | | | | |
|--|--|--|--|--|
| | | | | |
|--|--|--|--|--|



Check



Move the counters to the 5-frame. Count to find how many.

| | | | | |
|--|--|--|--|--|
| | | | | |
|--|--|--|--|--|

Representing Quantities Using Drawings

ML 1.17



Modeled Review



Name: Shawn

Draw circles to match the number of cubes.

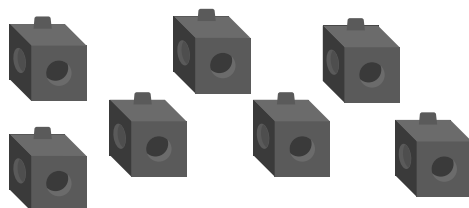

Guided Practice



Draw lines to match the cubes with the drawing that shows the same number.

1.

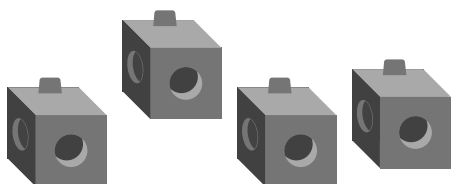

2.

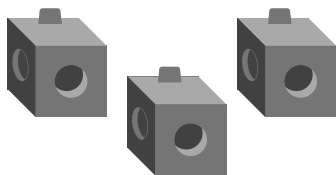

3.

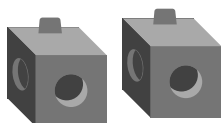



Guided Practice



Draw circles to show how many cubes.

4.

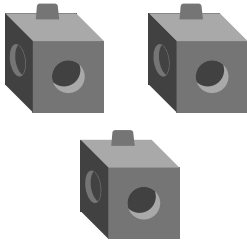

5.

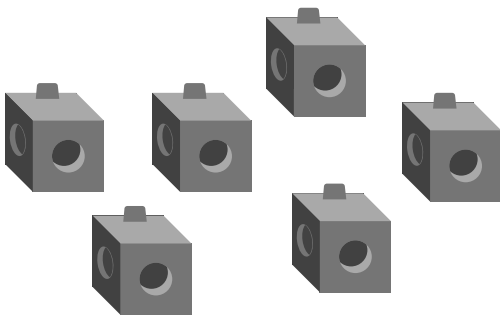

6.

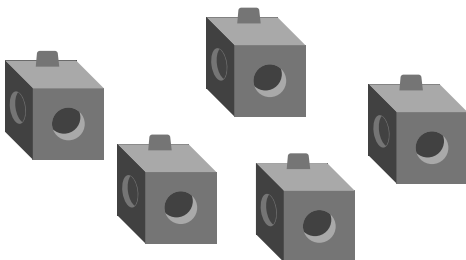

Check



Draw circles to show how many cubes.

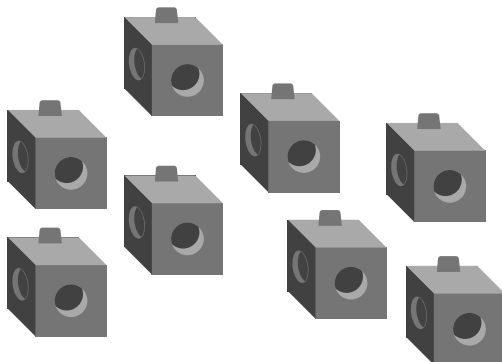

Asking and Answering "How Many?" Questions

ML 1.18



Modeled Review



How many counters are there?

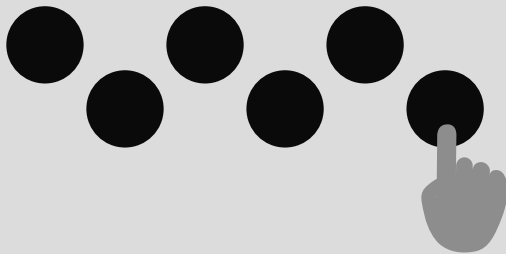

There are 6 counters.
When I counted, that
was the last number I
said.



Guided Practice



How many counters are there?









Guided Practice



How many counters are there?

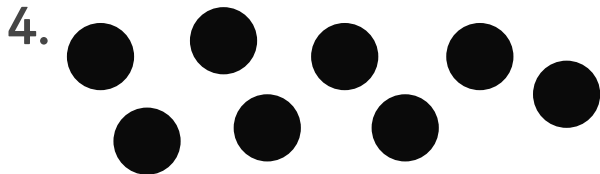

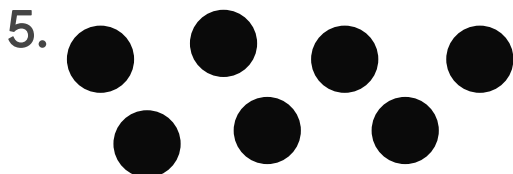

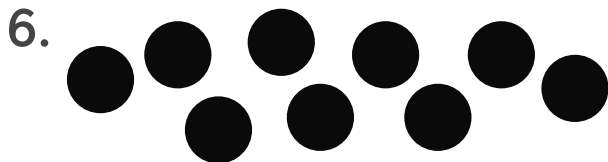

Check



How many counters are there?

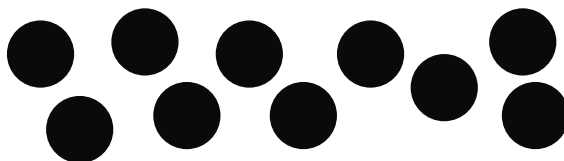

Unit 2

Mini-Lessons









Representing Numbers With Fingers

ML 2.02

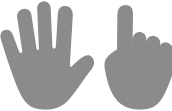

Modeled Review



| | | | | |
|--|--|--|---|---|
| 1  | 2  | 3  | 4  | 5  |
| 6  | 7  | 8  | 9  | 10  |



Guided Practice



1. Draw lines to match the fingers with the number that tells how many.

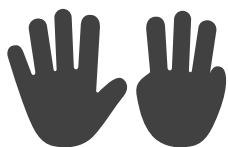

5



6



8



Guided Practice



2. Circle the hand that shows 4 fingers.



3. Circle the hand that shows 2 fingers.



4. Circle the hands that show 9 fingers.

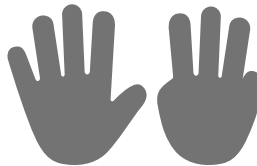
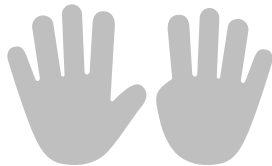

5. Circle the hands that show 7 fingers.

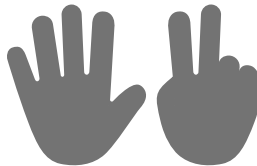
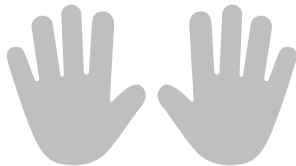

Check



Circle the hands that show 8 fingers.

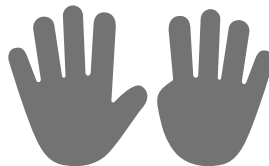
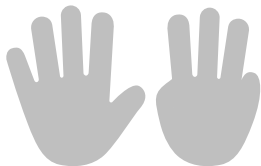

Counting the Same Objects in Different Arrangements

ML 2.03



Modeled Review



Name: Santiago

Count both groups of dots. Do they show the same number?

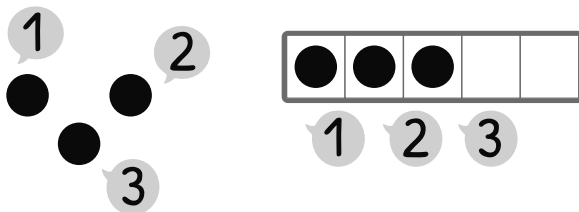

Both groups have 3 dots. They show the same number in different ways.



Guided Practice



Count both groups of dots. Do they show the same number?

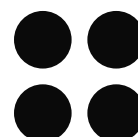



Guided Practice



3. Show the number your teacher tells you in **two** ways by putting counters in the 5-frame and on your desk.

| | | | | |
|--|--|--|--|--|
| | | | | |
|--|--|--|--|--|



Check



Show the number **5** in **two** ways by putting counters in the 5-frame and on your desk.

| | | | | |
|--|--|--|--|--|
| | | | | |
|--|--|--|--|--|

Exploring Different Ways to Compare Groups of Objects

ML 2.04



Modeled Review



Name: Han

1. Circle the group that shows *more* cubes.
2. Circle the group that shows *fewer* cubes.

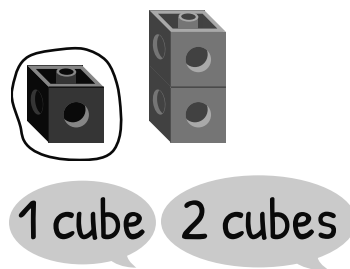
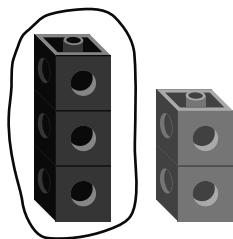

Guided Practice



1. Draw lines to match *more*, *fewer*, or the *same* to a group of dots showing the comparison.

more

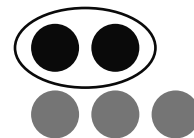

fewer

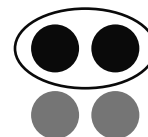

same

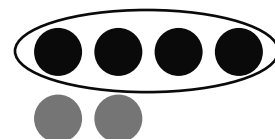



Guided Practice



Compare the cube towers. Circle the tower that matches the comparison.

2. *fewer*

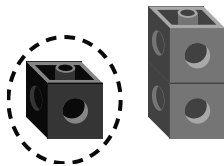

3. *more*

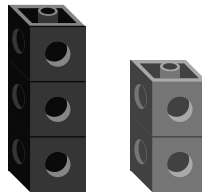

4. *more*

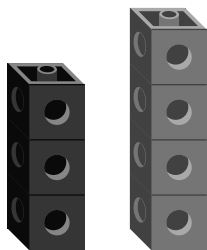

5. *fewer*

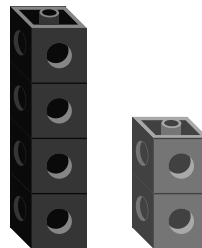

Check



Compare the cube towers. Circle the tower that matches the comparison.

1. *fewer*

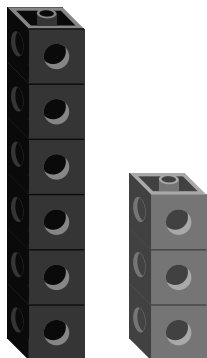

2. *more*

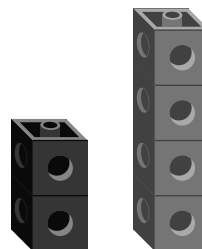

Reasoning About Groups With *More*, *Fewer*, or the *Same* Number of Objects

ML 2.05



Modeled Review



| Fewer | Same | More |
|-------|-------|---------|
| ● | ● ● ● | ● ● ● ● |



Guided Practice



Make a new group of dots in the box. Make your group *fewer*, the *same*, or *more* than the dots shown.

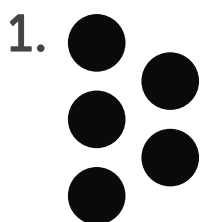

Fewer

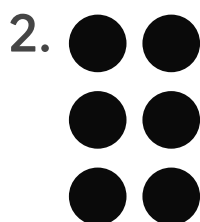

Fewer



Same





More



Guided Practice

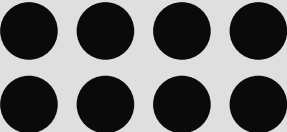

For each set of dots, make two new groups. Your groups should have *more* or *fewer* dots than the group shown.

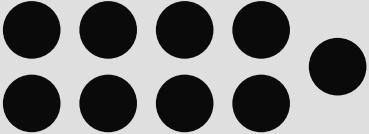
| Fewer | | More |
|-------|---|------|
| |  | |
| |  | |
| |  | |



Check



Make three groups of dots that have *more* or *fewer* dots than the group shown.



| Fewer | Same | More |
|-------|------|------|
| | | |

Comparing Objects Using *More*, *Fewer*, and the *Same*

ML 2.06



Modeled Review



Name: Avery

Compare the groups of dots using *more*, *fewer*, or the *same*.

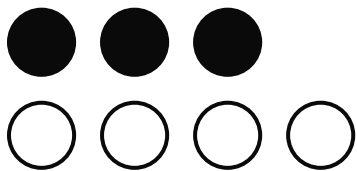

There are more white dots than black dots.
There are fewer black dots than white dots.



Guided Practice



Compare the cube towers using *more*, *fewer*, or the *same*.

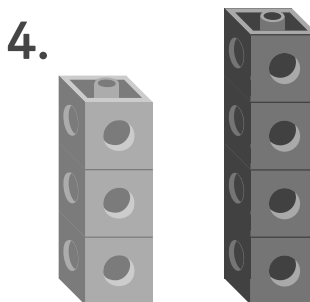
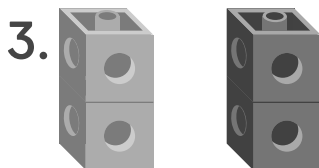
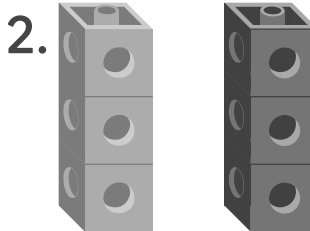
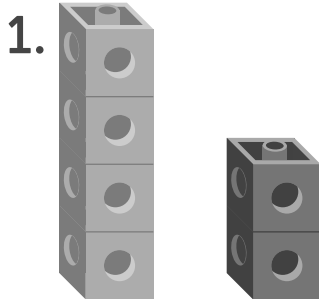



Guided Practice



Compare the groups of dots using *more*, *fewer*, or the *same*.

5. ● ● ●
○ ○ ○ ○ ○ ○

6. ● ● ● ●
○ ○ ○ ○

7. ● ● ● ● ● ● ● ●
○ ○ ○ ○ ○ ○



Check



Compare the groups of dots using *more*, *fewer*, or the *same*.

● ● ● ● ●
○ ○ ○ ○ ○ ○

Counting Objects in Scattered Arrangements

ML 2.07



Modeled Review



Name: Priya

Count to find how many.

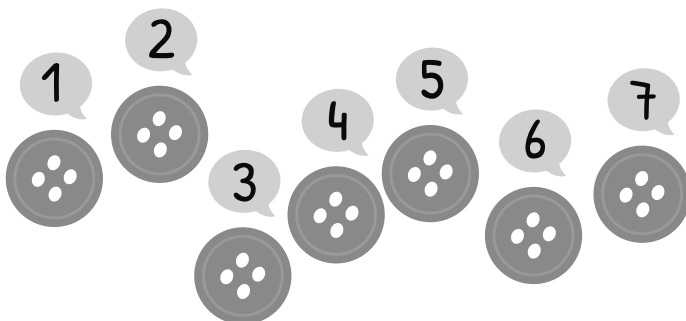

There are 7 buttons.



Guided Practice



Count to find how many.

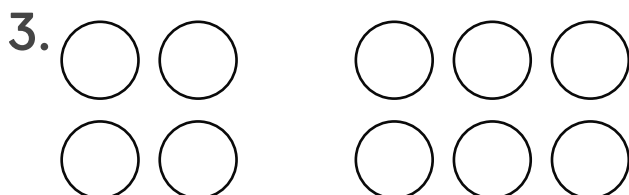
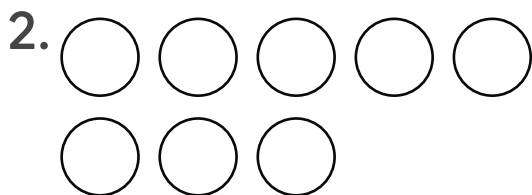



Guided Practice



Count to find how many.

4.

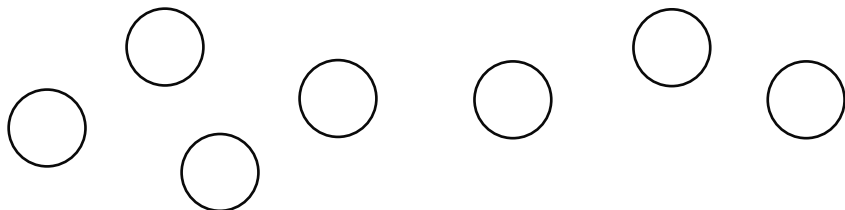

5.

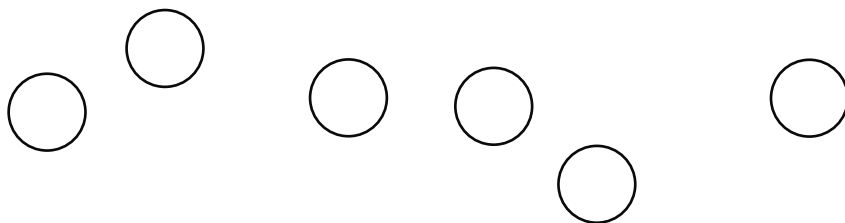

6.

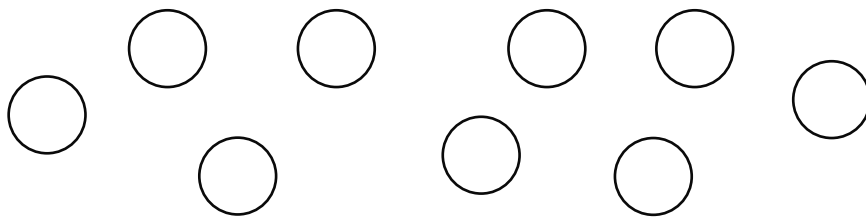

Check



Count to find how many.

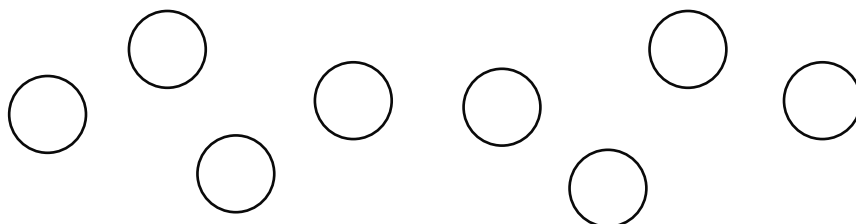

Using Matching to Compare

ML 2.08



Modeled Review



Name: Dylan

Draw lines to match the objects in each group. Then compare the two groups.



There are more hats than children.



Guided Practice



Draw lines to match the objects in each group. Circle the picture that makes the comparison true.

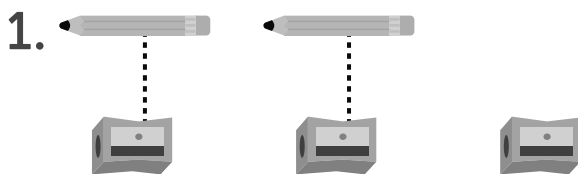

There are more

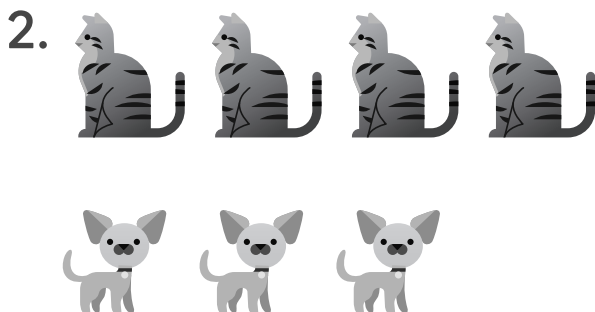
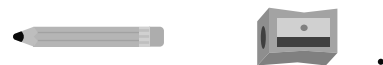

There are fewer





Guided Practice



Draw lines to match the objects in each group.
Then compare the two groups.

3.

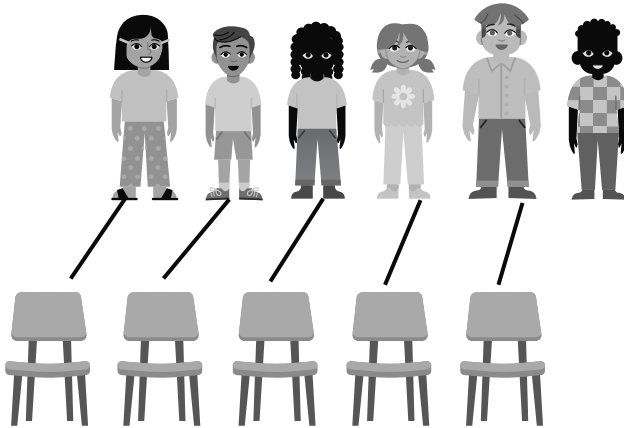

4.

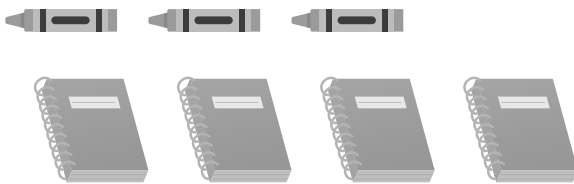

Check



Draw lines to match the objects in each group.
Then compare the two groups.

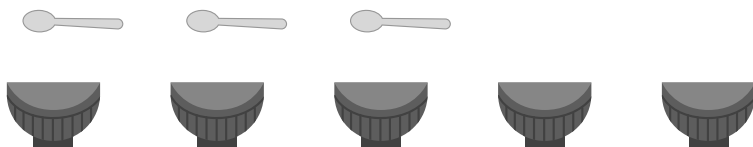

Comparing Two Groups of Objects Within 10

ML 2.09



Modeled Review



Name: Jack

Circle the 5-frame that shows *more*.

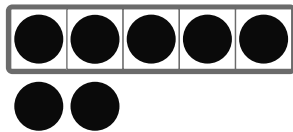

7

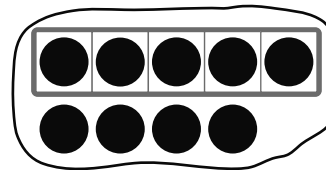

9



Guided Practice



1. Circle the 5-frame that matches the comparison.

| | | |
|--------------|--|--|
| <i>more</i> | | |
| <i>fewer</i> | | |
| <i>fewer</i> | | |



Guided Practice

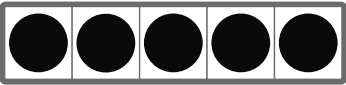
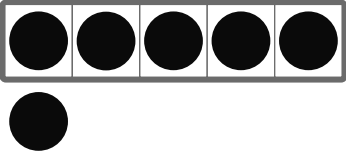
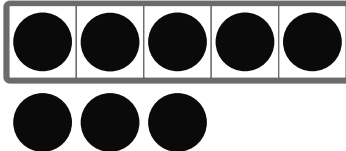
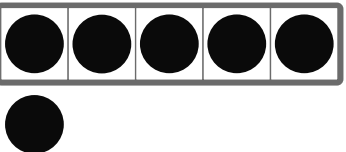
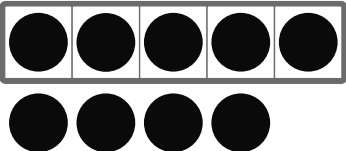
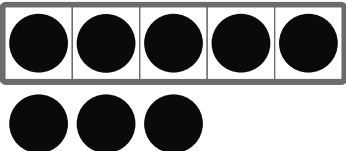

2. Circle the 5-frame that matches the comparison.

| | | |
|--------------|--|---|
| <i>more</i> |  |  |
| <i>more</i> |  |  |
| <i>fewer</i> |  |  |



Check



Circle the 5-frame that shows *fewer*.

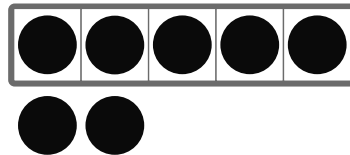
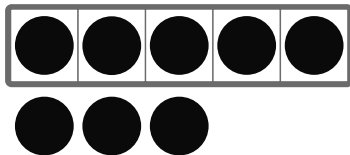

Identifying Groups That Show More or Fewer

ML 2.10



Modeled Review



Name: Diego

Circle the group that has more dots.

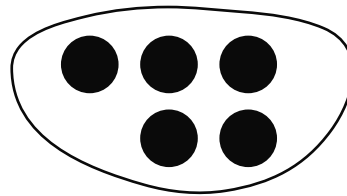

1, 2, 3. This group has 3 dots.

1, 2, 3, 4, 5. This group has 5 dots. 5 is more than 3.



Guided Practice



1. Circle the group that has *fewer* dots.

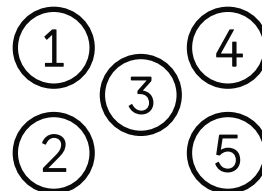

2. Circle the group that has *more* dots.

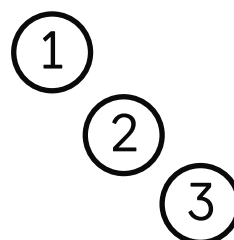



Guided Practice



3. Circle the group that has *more* dots.

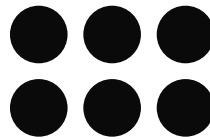
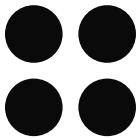

4. Circle the group that has *fewer* dots.

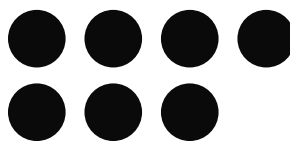
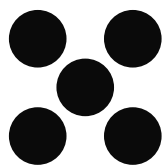

5. Circle the group that has *fewer* dots.

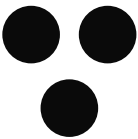

6. Circle the group that has *more* dots.

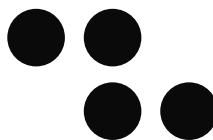

Check



Circle the group that has *more* dots.

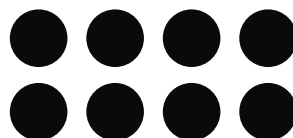
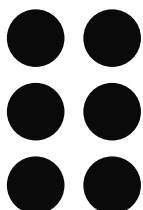

Drawing Groups With *More, Fewer,* or the *Same*

ML 2.11



Modeled Review



Name: Santiago

Draw a group with *fewer* dots than the first group.

1, 2, 3, 4, 5.
This group has 5 dots. I have to draw fewer dots so I will draw 3.

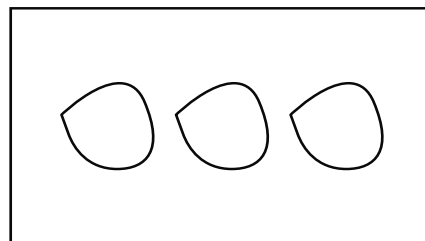
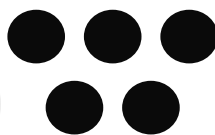

Guided Practice



For each group, draw another group with *fewer* dots.

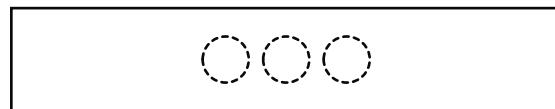



Guided Practice



For each group, draw another group with *more* dots.

4. ● ● ● ●



5. ● ●

6. ● ● ● ● ●
● ●

For each group, draw another group with *the same* number of dots.

7. ● ● ● ● ●

8. ● ● ● ● ●
● ● ● ●



Check



Draw another group with *fewer* dots.

● ● ● ● ●
● ●

Writing a Number to Show How Many

ML 2.12



Modeled Review



Name: Tristan

Count to find how many and write the number.

1 2 3 4 5

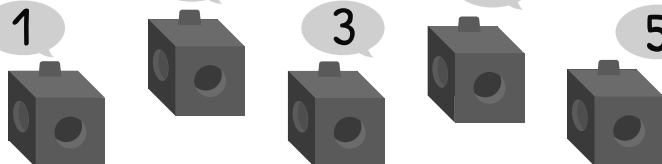

5



Guided Practice



Count to find how many and write the number.

1 2 3 4 5 6 7 8 9 10

1.

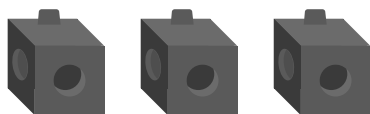

2.





Guided Practice



Count to find how many and write the number.

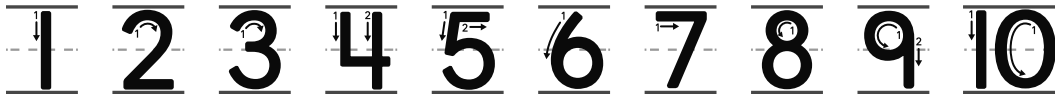

3.

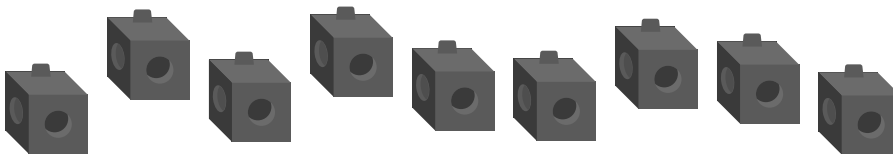

4.

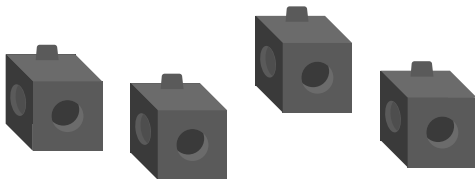

5.

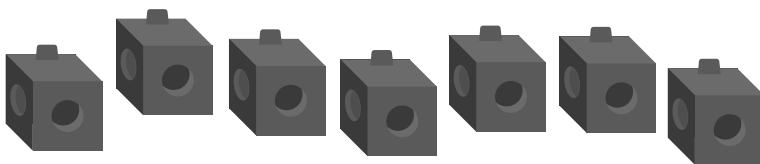



Check



Count to find how many and write the number.

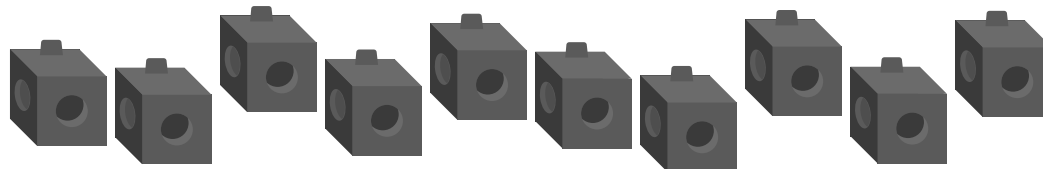

Matching Numbers to Groups of Objects

ML 2.13



Modeled Review



Name: Eva

Circle the group that shows 5.

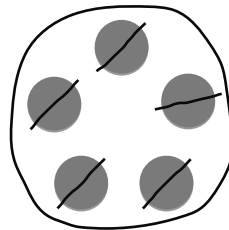
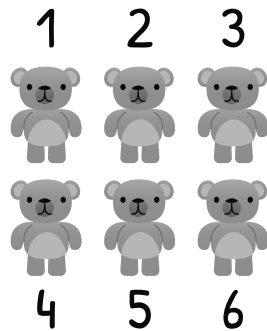

Guided Practice



1. Draw lines to match the group of objects to the number that represents it.

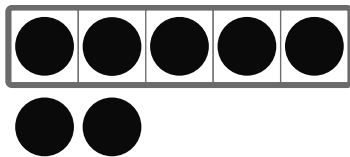

10



5

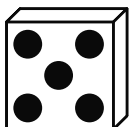

7



Guided Practice



2. Circle the group that shows 6.

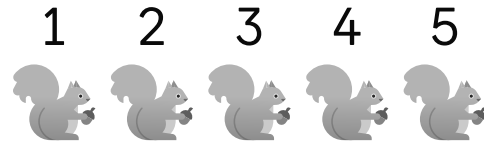
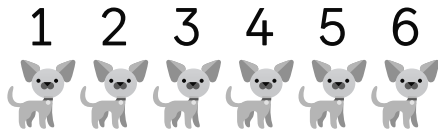

3. Circle the group that shows 3.

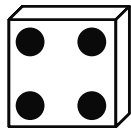

4. Circle the group that shows 7.

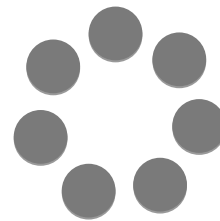

5. Circle the group that shows 9.

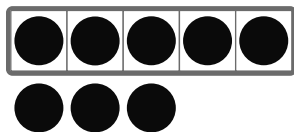

Check



Circle the group that shows 8.

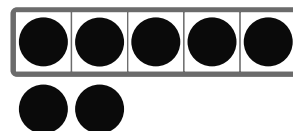

Counting Out Objects to Represent Numbers

ML 2.14



Modeled Review



Name: Tristan

Use counters to show the written number.

6

1 2 3 4 5

● ● ● ● ●

6

●



Guided Practice



Use counters to show the written number. Use the 5-frame if it is helpful.

| | | | | |
|--|--|--|--|--|
| | | | | |
|--|--|--|--|--|

1.

| |
|---|
| 3 |
|---|

2.

| |
|---|
| 5 |
|---|

3.

| |
|---|
| 2 |
|---|



Guided Practice



Use counters to show the written number.

4.

7

5.

10

6.

6

7.

8



Check



Use counters to show the written number.

9

Drawing Objects to Represent a Written Number

ML 2.15



Modeled Review



Name: Jack

Draw a group of objects to show the number.

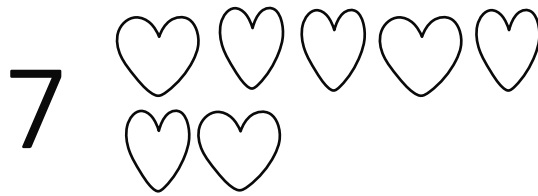

I know the number is 7, so I drew 7 hearts.



Guided Practice



Draw circles in the 5-frame to show the number.

1. 2

| | | | | |
|---|---|--|--|--|
| ○ | ○ | | | |
|---|---|--|--|--|

2. 5

| | | | | |
|--|--|--|--|--|
| | | | | |
|--|--|--|--|--|

3. 3

| | | | | |
|--|--|--|--|--|
| | | | | |
|--|--|--|--|--|



Guided Practice



Draw circles to show the number.

4.

7

5.

9

6.

6



Check



Draw circles to show the number.

8

Writing Numbers to Represent a Quantity

ML 2.16



Modeled Review



Name: Maya

Count the images. Write the number that tells how many.

1 2 3 4 5 6

_____ 6 _____



Guided Practice



Count the images. Write the number that tells how many.

1. _____

_____ 5 _____

2. _____

_____ 8 _____



Guided Practice



Count the images. Write the number that tells how many.

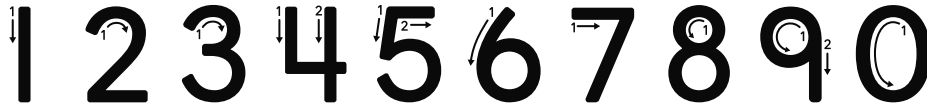

3.

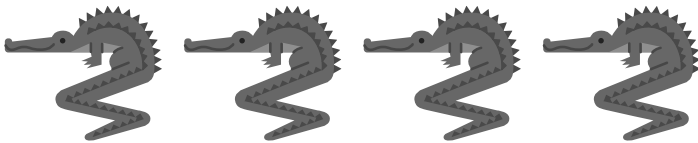

4.

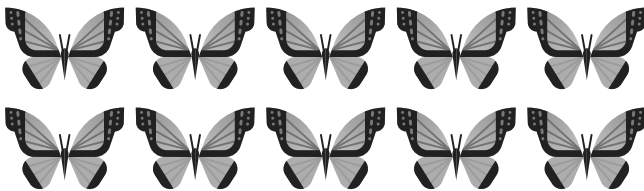

5.

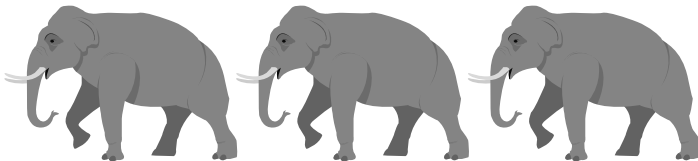

6.

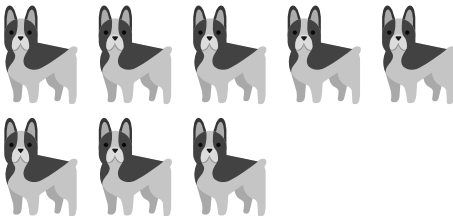



Check



Count the images. Write the number that tells how many.

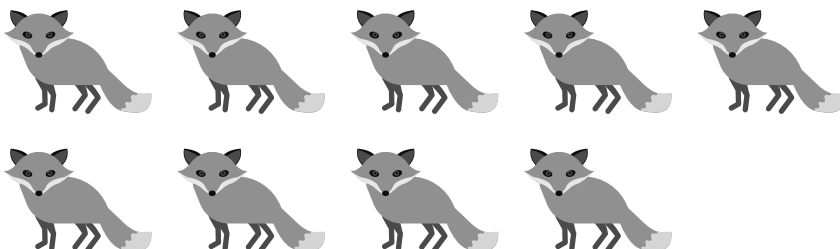

Ordering the Numbers 1-10

ML 2.17



Modeled Review



1
2
3
4
5
6
6
5
4
3
2
1

counting forward counting backward



Guided Practice



1. Fill in the blanks for the missing numbers.
Build a cube tower for each missing number if it is helpful.

1
3
4
6
8
9



Guided Practice



Fill in the blanks for the missing numbers.
Build a cube tower for each missing number
if it is helpful.

2.

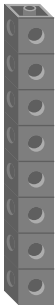

8

6

3.



3

5

7



Check



Fill in the blanks for the missing numbers.
Build a cube tower for each missing number
if it is helpful.



10

8

7

5

3

1

Finding 1 More and 1 Less Than a Given Number

ML 2.18



Modeled Review



Name: Diego

Write numbers to show 1 less and 1 more than the tower.

| 1 less | Tower | 1 more |
|--------|-------|--------|
| 3 | 4 | 5 |

The tower has 4 cubes. 1,2,3,4,5. One less than 4 is 3. One more than 4 is 5.



Guided Practice



1. Write numbers to show 1 less and 1 more than the tower.

| 1 less | Tower | 1 more |
|-----------------|-------|-----------------|
| — - - - — | 2 | — - - - — |

| 1 less | Tower | 1 more |
|-----------------|-------|-----------------|
| — - - - — | 5 | — - - - — |



Guided Practice



2. Write numbers to show 1 less and 1 more.

| 1 less | | 1 more |
|-------------------|----------|-------------------|
| <hr/> <hr/> <hr/> | 9 | <hr/> <hr/> <hr/> |
| <hr/> <hr/> <hr/> | 3 | <hr/> <hr/> <hr/> |
| <hr/> <hr/> <hr/> | 6 | <hr/> <hr/> <hr/> |



Check



Write numbers to show 1 less and 1 more.

| 1 less | | 1 more |
|-------------------|----------|-------------------|
| <hr/> <hr/> <hr/> | 8 | <hr/> <hr/> <hr/> |

Representing Numbers 1-10 in Different Ways

ML 2.19



Modeled Review



Name: Priya

Show the number 7 in *two* different ways using cubes and drawings.

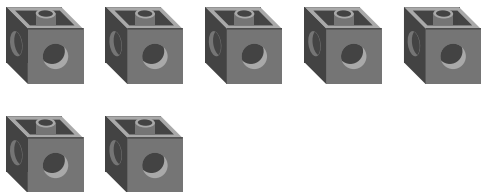

Guided Practice



1. Show the number 6 with a drawing.

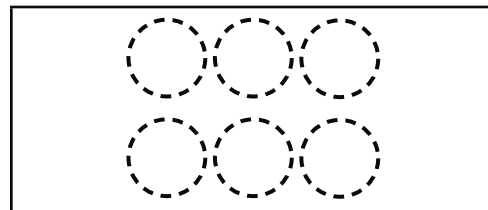
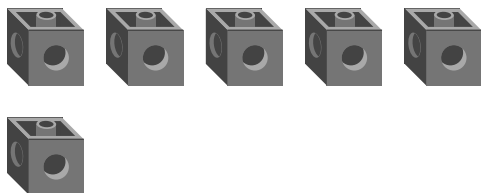

2. Show the number 4 with cubes and a drawing.





Guided Practice



Show each number in *two* different ways with cubes and drawings.

3.5

4.7

5.9



Check



Show the number 8 in *two* different ways with cubes and drawings.

Comparing Written Numbers and Groups of Objects

ML 2.20



Modeled Review



Name: Diego

Circle the number or group that shows *more*.

1 2 3 4 5
● ● ● ● ●
6
●



There are 6 dots. 9 is more than 6, so I circled the 9.



Guided Practice



1. Circle the number and group that show *more*.

2. Circle the number and group that show *less*.

5

3

2

4



Guided Practice



3. Circle the number or group that shows *more*.

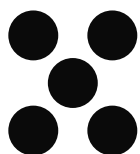

7

4. Circle the number or group that shows *less*.

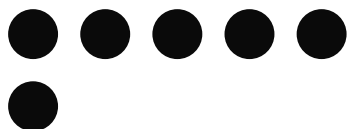

8

5. Circle the number or group that shows *more*.

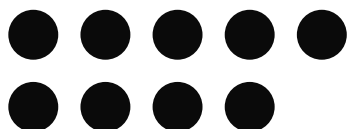

10



Check



Circle the number or group that shows *more*.



6

Comparing Two Written Numbers

ML 2.21



Modeled Review

Name: Han

Circle the written number that shows *more*.

5



7



1,2,3,4,5,6,7.
7 comes after 5.
7 is more than 5.



Guided Practice



Circle the written number that shows *more*.
Use counters or drawings if it is helpful.

1.

6



4



2.

3

5



Guided Practice



Circle the written number that shows *less*. Use counters or drawings if it is helpful.

3.

8

5



4.

2

3

5.

4

7



Check



Circle the written number that shows *more*. Use counters or drawings if it is helpful.

9

7

Writing and Comparing Numbers

ML 2.22



Modeled Review



Name: Shawn

Count the fish. Write the numbers that tell how many. Circle the number that is *less*.

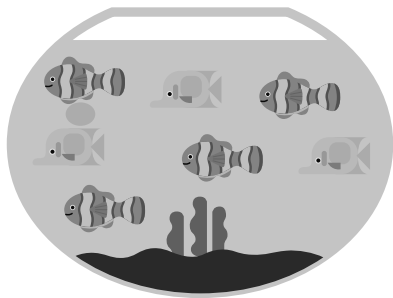

4

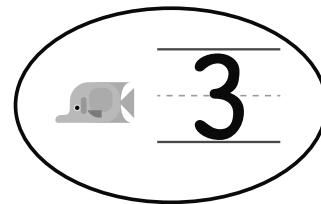

Guided Practice



1. Circle the number that is *more*.

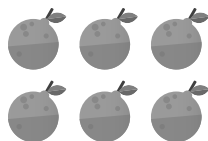

5

6

2. Circle the number that is *less*.

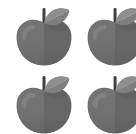

3

4



Guided Practice



Count the vegetables. Write the number that tells how many.

3. Circle the number that is *more*.



4. Circle the number that is *less*.

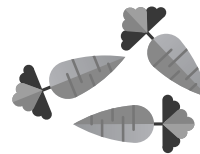



Check



Count the leaves. Write the numbers that tell how many. Circle the number that is *more*.

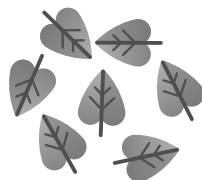



Unit 3

Mini-Lessons

Describing Shapes

ML 3.02



Modeled Review



Name: Jada

Describe the shapes by their attributes.

This shape is round.

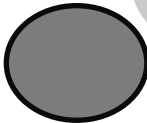

This shape is small.



This shape has 3 sides and corners.





Guided Practice

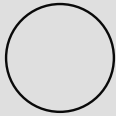
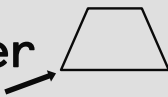
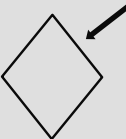
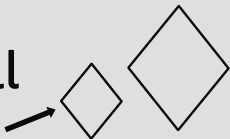

Use the word bank for Problems 1-4.

round  corner  side  small 

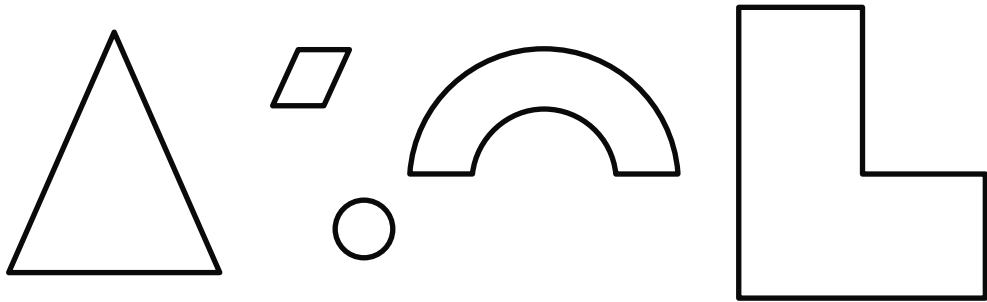
1. Point to a shape that is small.
2. Point to a shape that is round.
3. Point to a shape that has a corner.
4. Point to a shape that has a side.





Guided Practice



Circle the words that make the statement true.

5. This shape  is round. has corners.

6. This shape  has 3 sides. has 4 sides.

7. Choose a shape. Describe the shape to your partner.

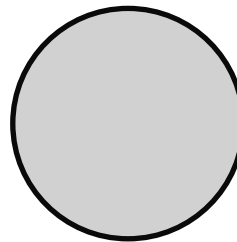
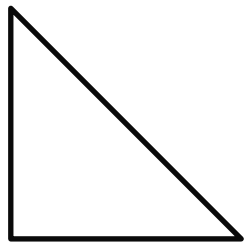

Check



Choose a shape. Describe the shape to your partner.

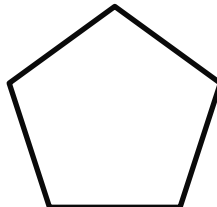

Matching Shapes

ML 3.03



Modeled Review



Name: Diego

Circle 2 shapes that match the shaded shape.

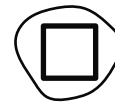
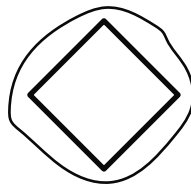
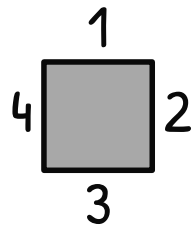

Guided Practice



1. Draw lines to match the shapes.

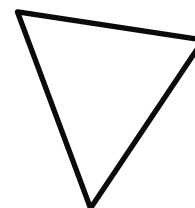
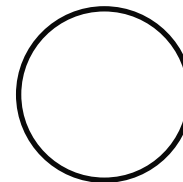
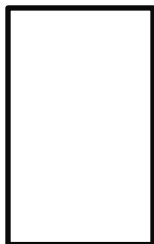
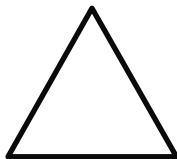



Guided Practice



Circle the 2 shapes that match the shaded shape.

2.

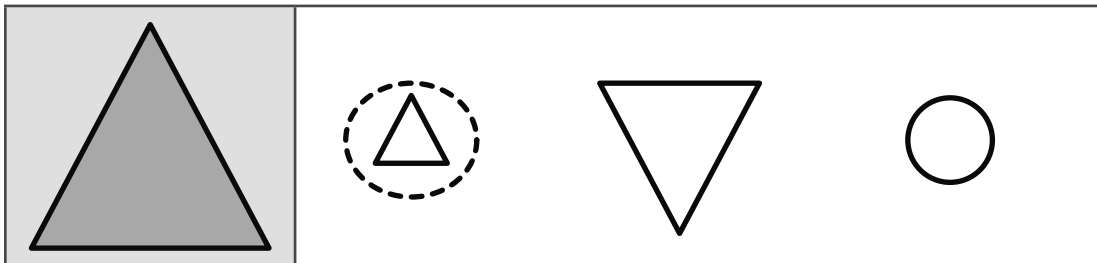

3.

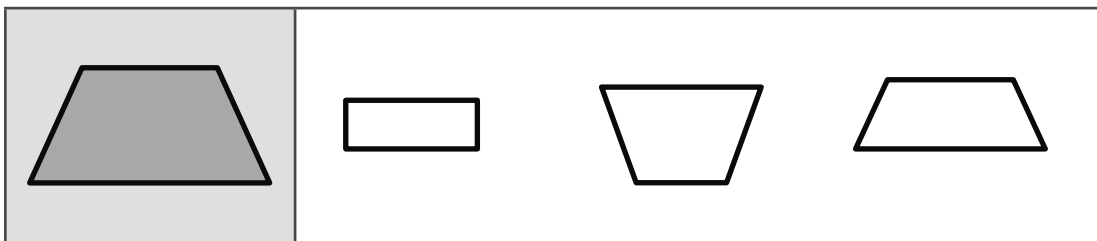

4.

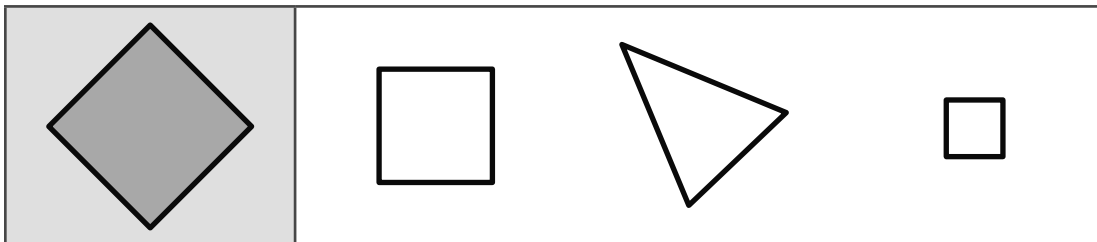

5.

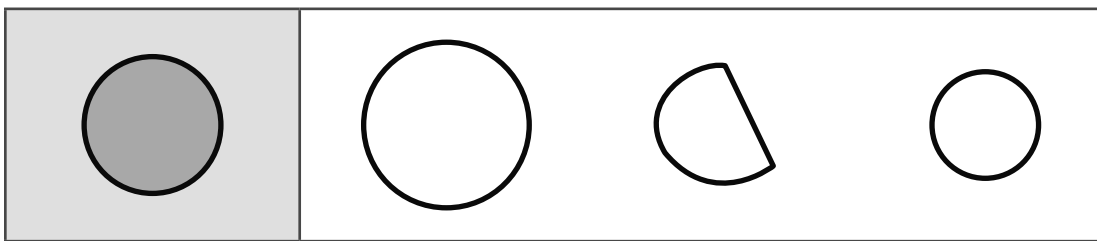

Check



Circle the 2 shapes that match the shaded shape.

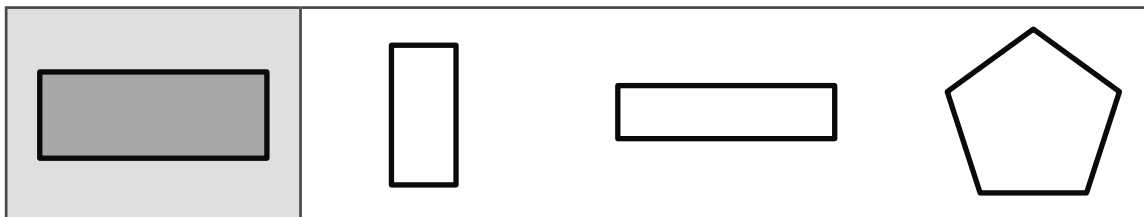

Comparing Shapes

ML 3.04



Modeled Review



Name: Priya

Circle 2 shapes that are alike. Explain your thinking.

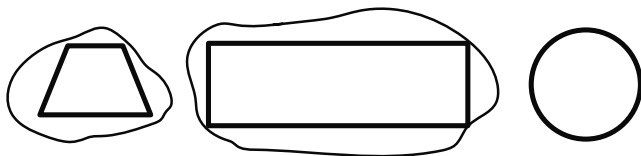

These shapes are alike because they have 4 corners and 4 straight sides.



Guided Practice



How many corners and sides does each shape have?

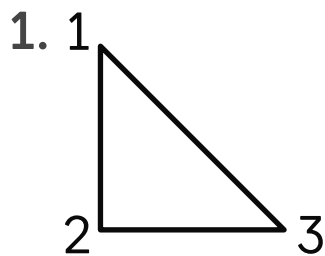

_____ corners 3 sides

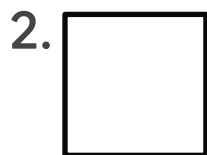

_____ corners _____ sides



Guided Practice



Circle 2 shapes that are alike. Explain your thinking.

3.

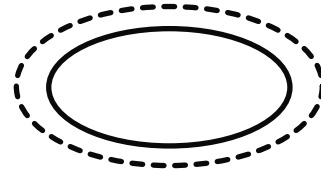
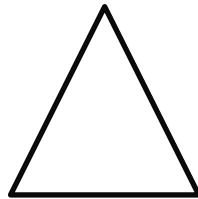
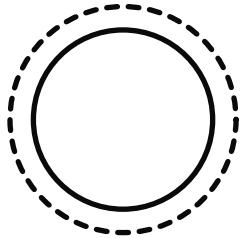

4.

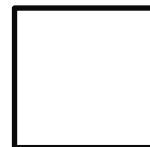
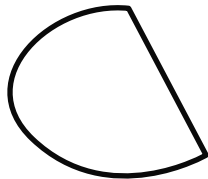

5.

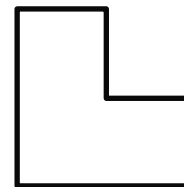
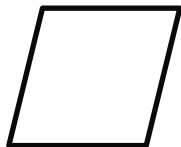

Check



Circle 2 shapes that are alike. Explain your thinking.

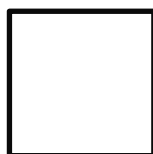
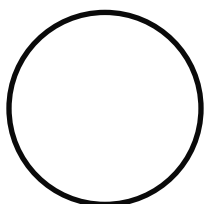

Sorting Shapes Into Categories

ML 3.05



Modeled Review

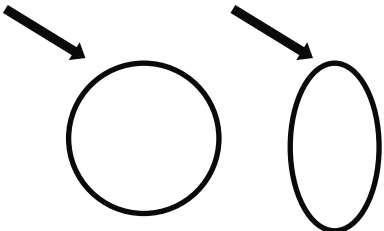
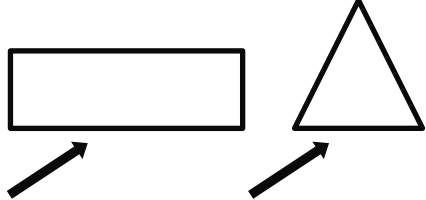

| curved | straight |
|---|--|
|  |  |



Guided Practice



Use the following shapes for Problems 1-2.

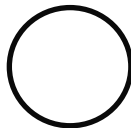
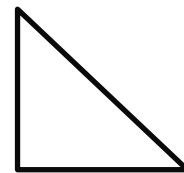
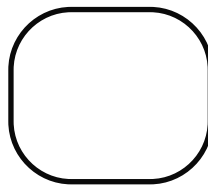

1. Circle the shapes that have *curved* parts.
2. Color the shapes that have *straight* sides.



Guided Practice



3. Circle the shapes that *do not* have curved parts.

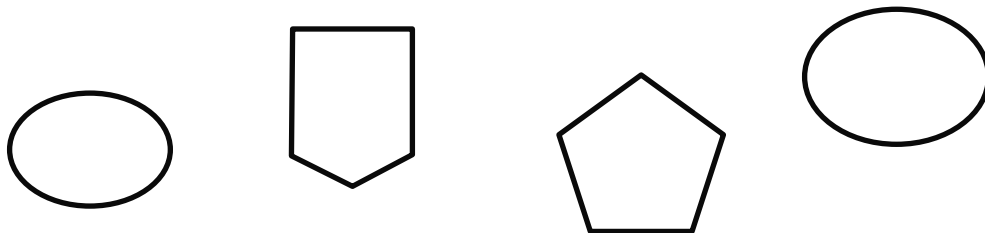

4. Circle the shapes that *do not* have straight sides.

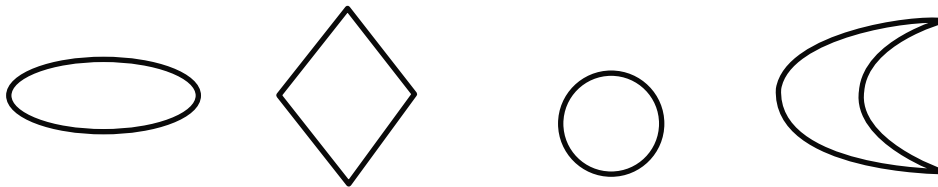

Check



Use the following shapes for Problems 1-2.

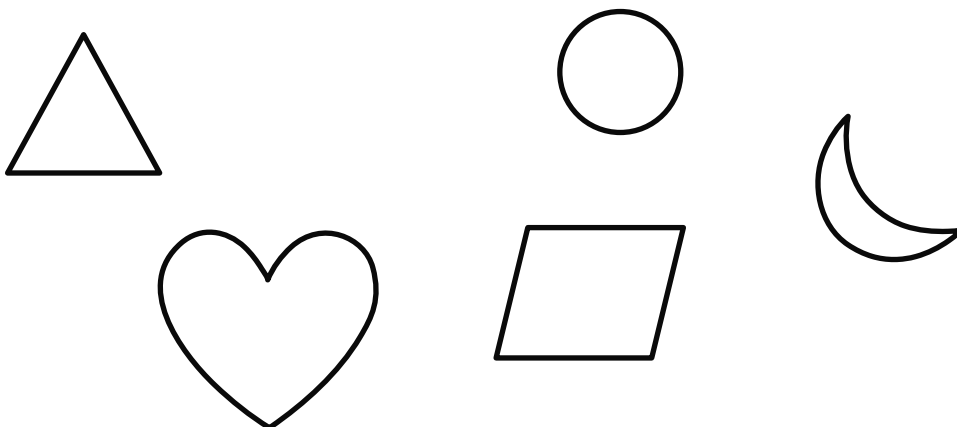

1. Circle the shapes that *do not* have curved parts.

2. Color the shapes that *do not* have straight sides.

Identifying Circles and Triangles

ML 3.06



Modeled Review



Name: Jack

Color *all* the circles. Draw a box around *all* the triangles.

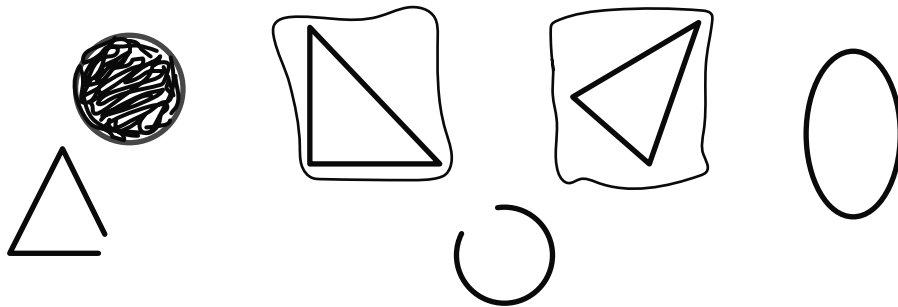

Guided Practice



1. Color *all* the triangles.

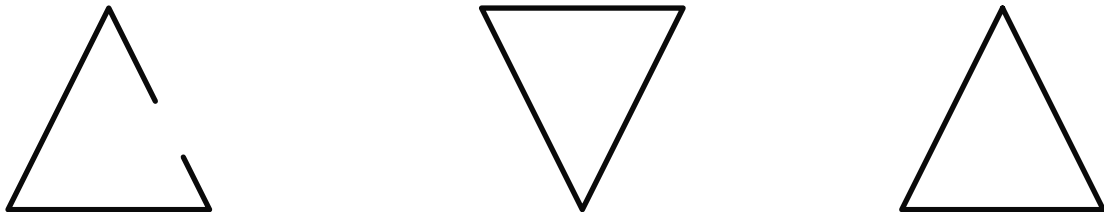

2. Color *all* the circles.





Guided Practice



3. Color *all* the circles. Draw a box around *all* the triangles.

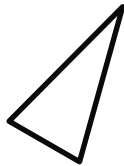
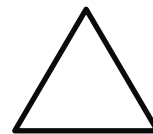
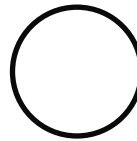
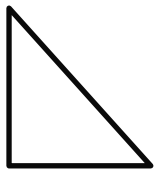

Check



Color *all* the circles. Draw a box around *all* the triangles.

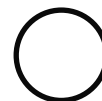
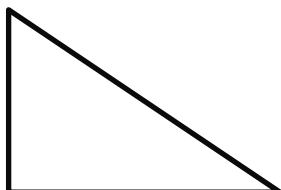
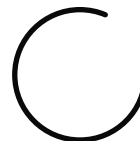
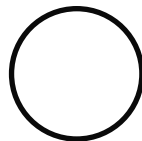

Identifying and Comparing Rectangles

ML 3.07



Modeled Review



Name: Avery

Color *all* the rectangles.

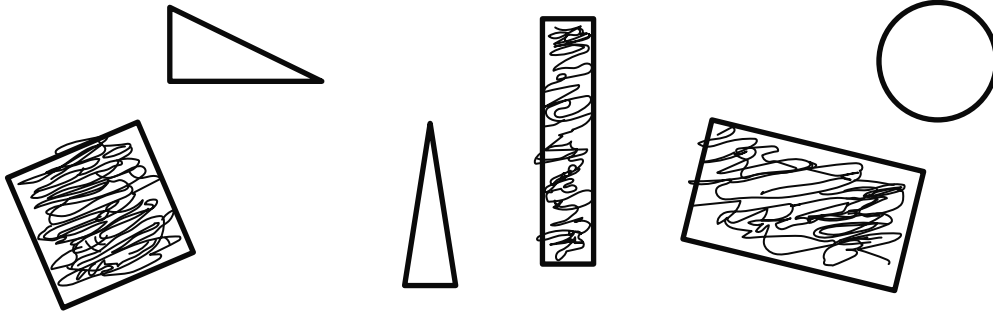

Guided Practice



1. Color *all* the rectangles.

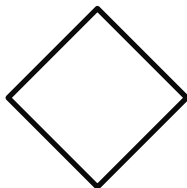
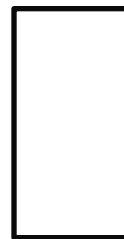



Guided Practice



2. Color *all* the rectangles. Explain your thinking.

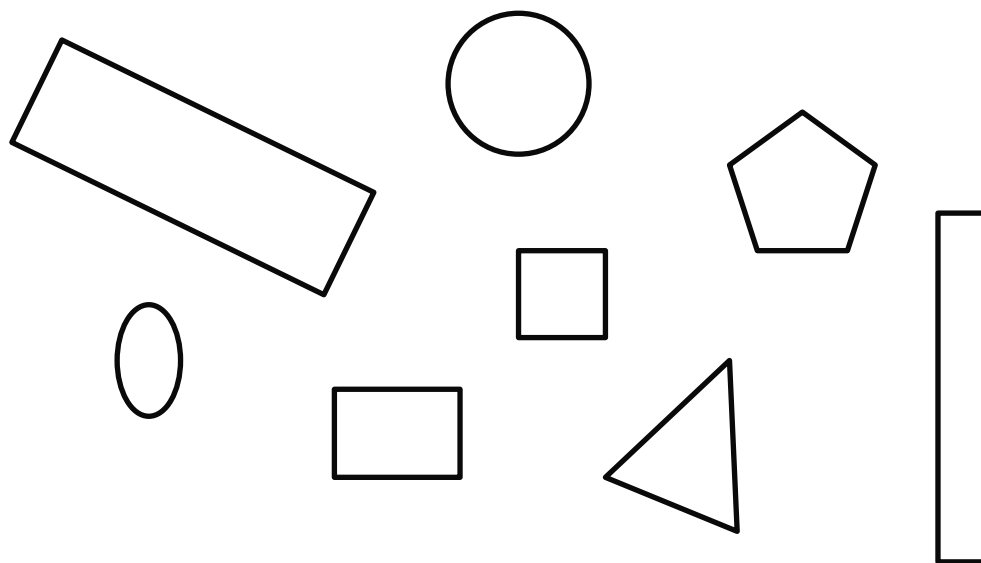

Check



Color *all* the rectangles. Explain your thinking.

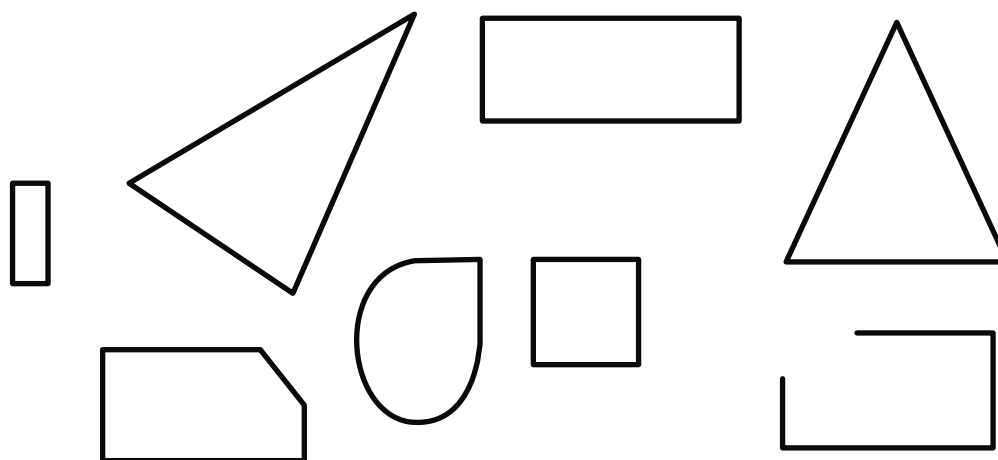

Using *Longer* and *Shorter* to Compare Lengths

ML 3.08



Modeled Review



Name: Han

1. Circle the object that is *longer*.

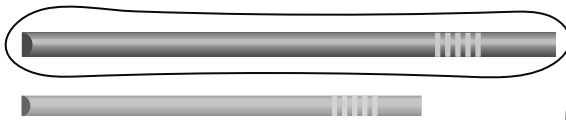

2. Circle the object that is *shorter*.

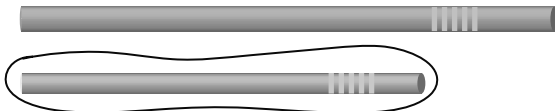

I could look at both ends of the objects to figure out which is longer or shorter.



Guided Practice



Draw lines to match the word with the circled image that represents it.

1. longer



2. shorter

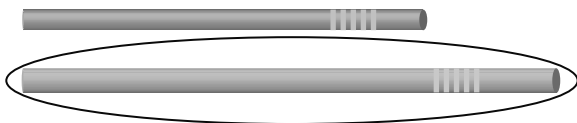



Guided Practice



Draw circles to match the word with the image that represents it.

3. longer

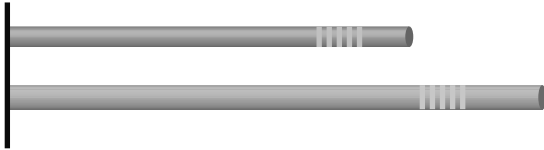

4. shorter



5. longer



Check



Draw circles to match the word with the image that represents it.

1. longer



2. shorter



Sorting Shapes Into Subcategories

ML 3.09



Modeled Review

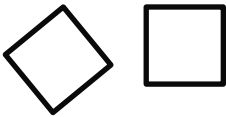
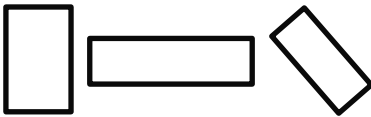

Eva sorted the shapes into 2 subcategories.

| Squares | Rectangles but <i>not</i> squares |
|--|---|
|  <p>These shapes have sides that are all the same length.</p> |  <p>These shapes have two long sides and two short sides.</p> |



Guided Practice



1. Color the shape with 2 long sides and 2 short sides.



2. Color the shape with 4 equal sides.

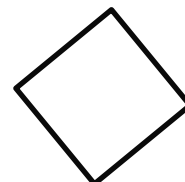
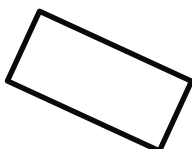



Guided Practice



Use the following shapes for Problems 3–4.

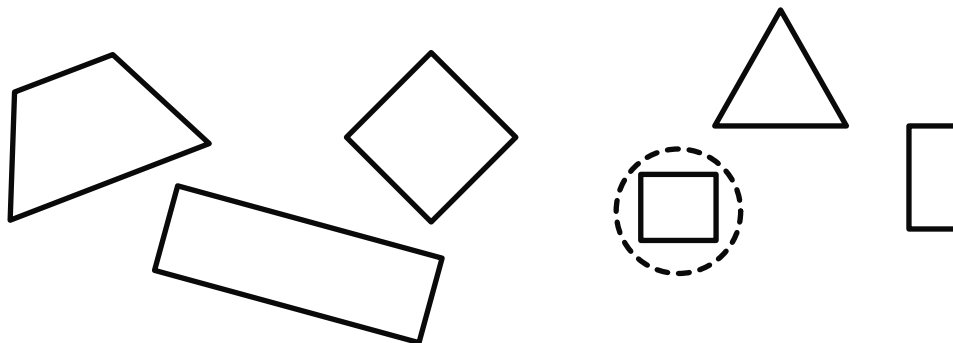

3. Color the **2** shapes that are rectangles but *not* squares.
4. Circle *all* the squares.



Check



Use the following shapes for Problems 1–2.

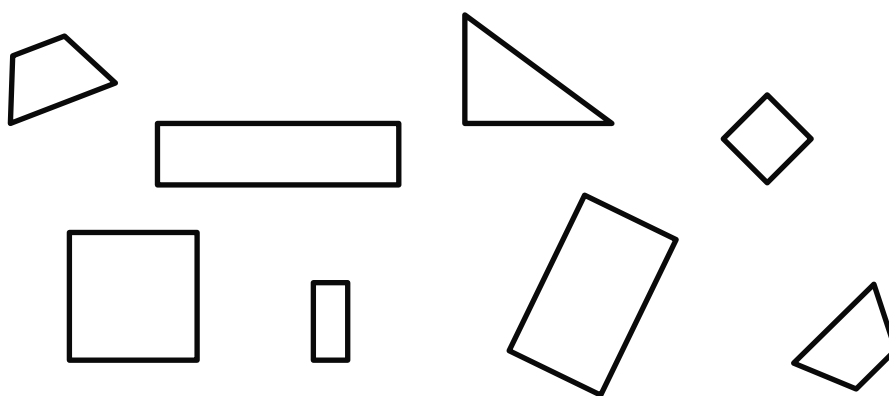

1. Circle the **3** shapes that are rectangles but *not* squares.
2. Color *all* the squares.

Drawing Shapes

ML 3.10



Modeled Review



Name: Tristan

Draw a shape with 4 straight sides and 4 corners.

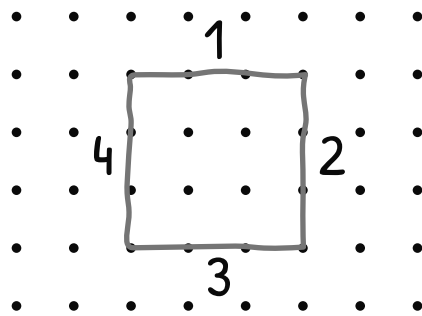

Guided Practice



1. Connect the points with straight lines. Then match the shape to the description.

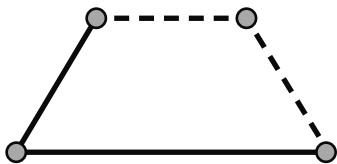

3 corners, 3 sides



4 corners, 4 sides





Guided Practice



2. Draw a shape with 5 straight sides and 5 corners.

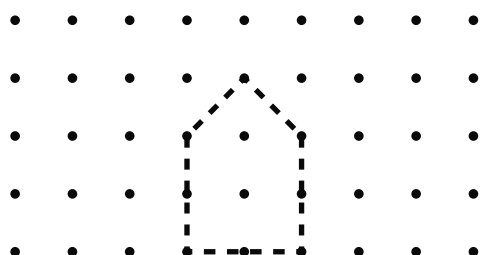

3. Draw a shape with 3 straight sides and 3 corners.

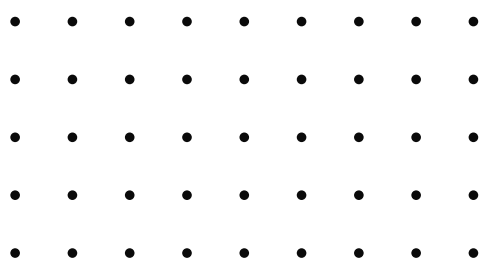

Check



Draw a shape with 6 straight sides and 6 corners.

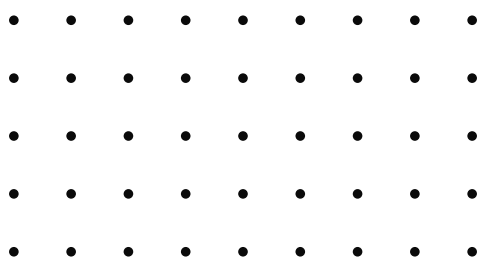

Describing and Naming Shapes

ML 3.11



Modeled Review



Name: Clare

Draw 2 shapes that you see in the picture.
Describe the shapes you drew to your partner.

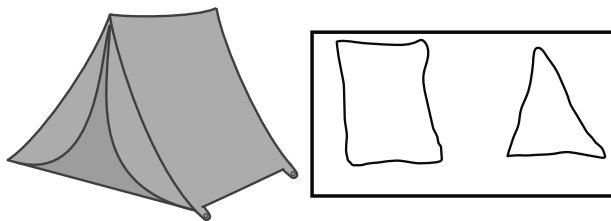

The side looks like a rectangle. It has 4 corners.

The door looks like a triangle. It has 3 sides.



Guided Practice



1. Draw lines to match the shape with a real-world object that has the same shape.

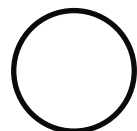
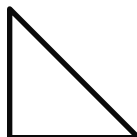
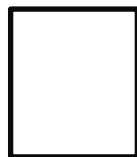



Guided Practice



2. Draw 2 shapes you see in the picture. Describe the shapes to a partner. Use the shapes in the bank if it is helpful.

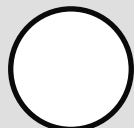

| Picture | Shapes | |
|---------|--------|--|
| | | |
| | | |
| | | |



Check



Draw 2 shapes you see in the picture. Describe the shapes to a partner.

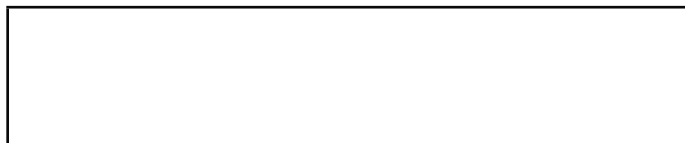

Putting Shapes Together to Form Larger Shapes

ML 3.12



Modeled Review



Name: Shawn

Count out the pattern blocks you need and use them to build an object. Then describe the object you made.

6  orange squares

1  yellow hexagon

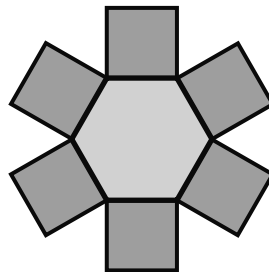

I made a sun!



Guided Practice



1. Match the objects to the pattern blocks used to create them.

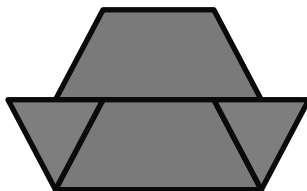

2  orange squares
1  blue rhombus

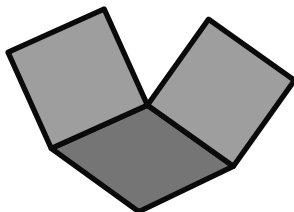

2  red trapezoids
2  green triangles



Guided Practice



Count out the pattern blocks you need and use them to build an object. Then describe the object you built.

2. 2  green triangles

3. 2  blue rhombuses

2  orange squares

2  red trapezoids

1  yellow hexagon

3  green triangles



Check



Count out the pattern blocks you need and use them to build an object. Then describe the object you built.

2  yellow hexagons

2  blue rhombuses

4  green triangles

Sliding, Turning, and Flipping Shapes to Match Exactly

ML 3.13



Modeled Review



Name: Jada

Complete the puzzle with pattern blocks.

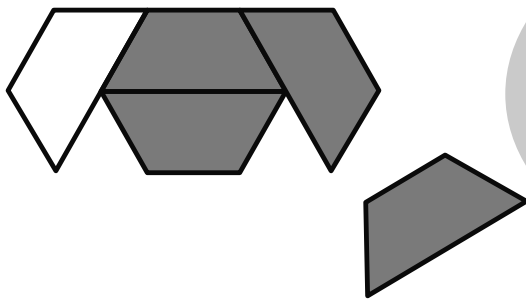

I looked at the sides and corners to pick a shape. I need to turn and slide the trapezoid to finish the puzzle.



Guided Practice



1. Circle the pattern block that completes the puzzle.

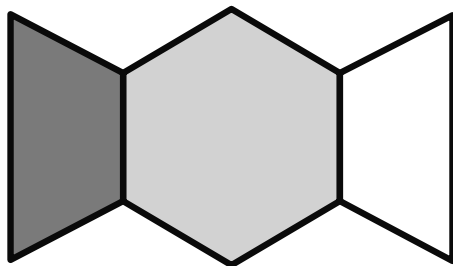

| | |
|--|--|
| | |
| | |
| | |



Guided Practice



2. Complete the puzzle with pattern blocks.

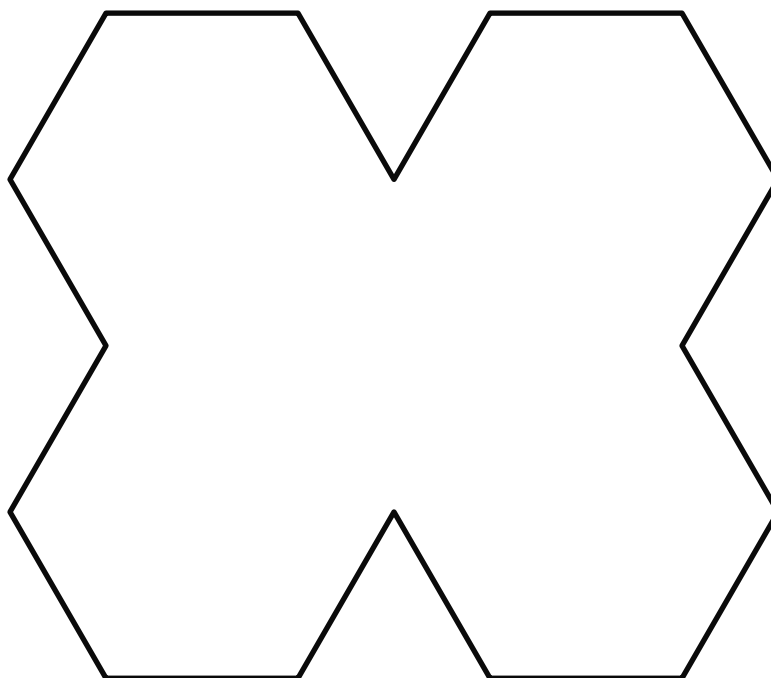

Check



Complete the puzzle with pattern blocks.

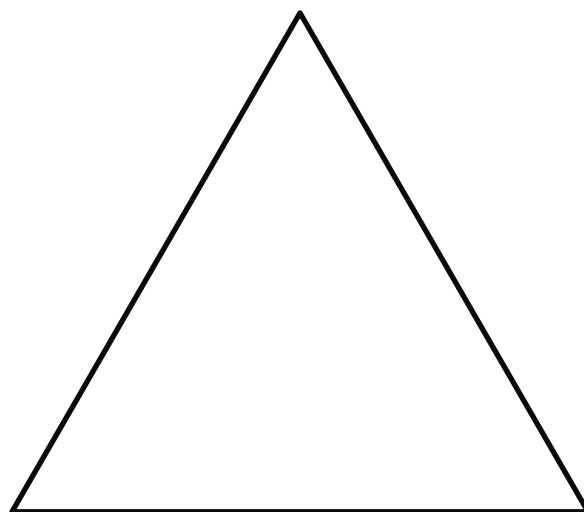

Forming Larger Shapes in Different Ways

ML 3.14



Modeled Review



Diego and Maya used pattern blocks to complete the puzzle.

Diego

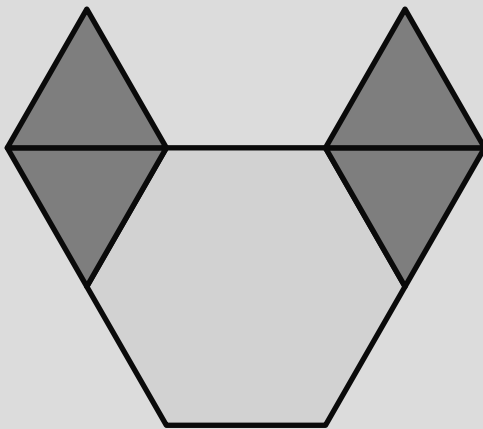

Maya

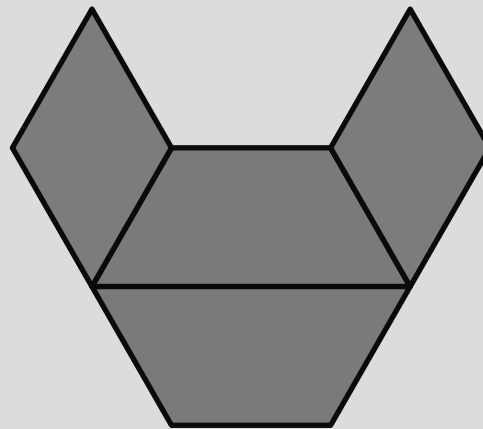

Guided Practice



1. Use pattern blocks to make the hexagon in a different way.

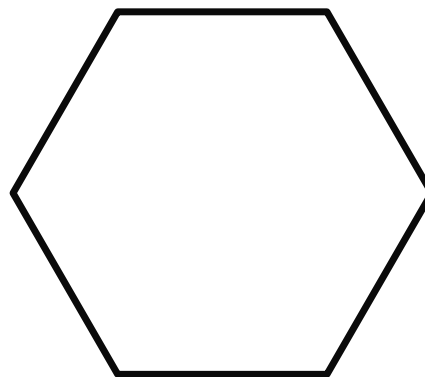
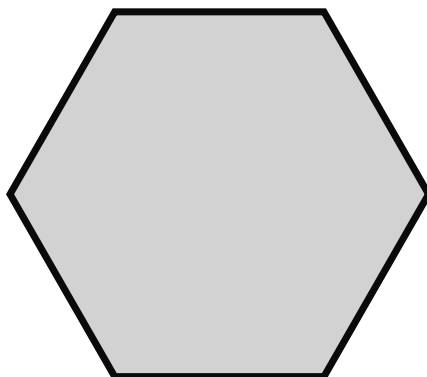



Guided Practice



2. Use pattern blocks to complete the puzzle in two different ways.

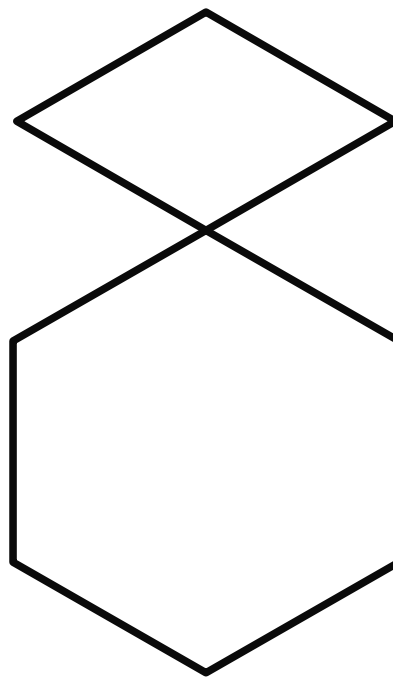
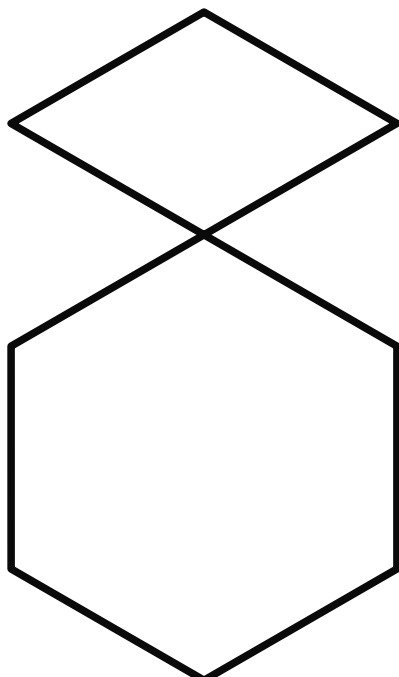

Check



Use pattern blocks to complete the puzzle in two different ways.



Describing the Position of Shapes

ML 3.15



Modeled Review



Where is the circle?

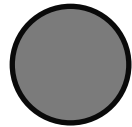

above

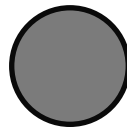

below

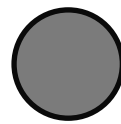

next to



Guided Practice



Use the image below for Problems 1–3.

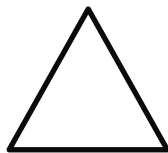

1. Put a check on the shape that is *above* the square.
2. Color the shape that is *below* the triangle.
3. Put an X on the shape that is *next to* the circle.



Guided Practice



Use a pattern block and the image below for Problems 4–5.



4. Put your pattern block *above* the square.
5. Put your pattern block *next* to the triangle.



Check



Use a pattern block and the image below for Problems 1–2.

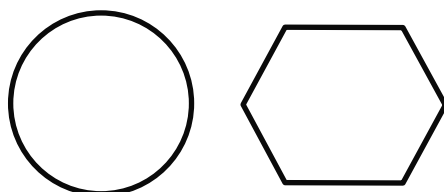

1. Put your pattern block *below* the hexagon.
2. Put your pattern block *next* to the circle.

Drawing Simple Shapes to Form Larger Shapes

ML 3.16



Modeled Review



Name: Priya

Draw a real-world object with a triangle and a rectangle.

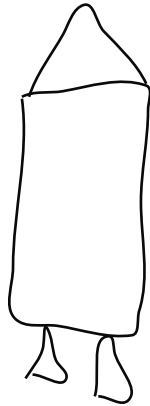
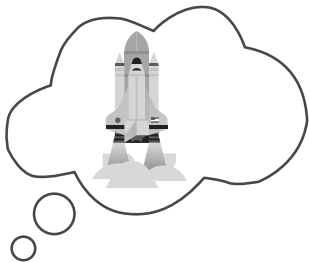

The top of the rocket is a triangle. The fire is two triangles. The rest is a rectangle.



Guided Practice



1. Draw lines to match the pictures of real-world objects with the drawings made of shapes.

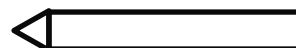



Guided Practice



2. Draw the traffic light using a rectangle and circles.



3. Draw a real-world object using at least one circle and one rectangle. Describe your object to a partner.



Check



Draw a real-world object with at least one triangle and one rectangle. Describe your object to a partner.

Unit 4

Mini-Lessons

Counting to Find the Total Number of Objects in Two Groups

ML 4.02



Modeled Review

Name: Shawn

Count to find the total number of cubes. Then fill in the sentence.

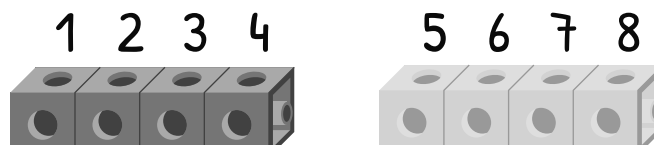

There are 8 cubes.



Guided Practice



- Count to find the total number of cubes. Draw a line from the cubes to the number that matches the count.

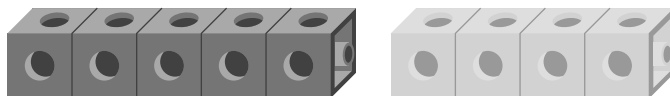

4

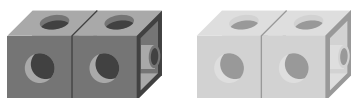

7

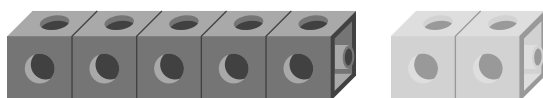

9



Guided Practice



Count to find the total number of cubes. Then fill in each sentence.

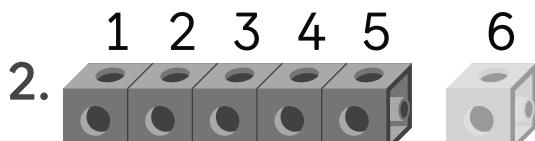

There are cubes.

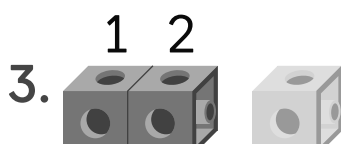

There are cubes.



There are cubes.

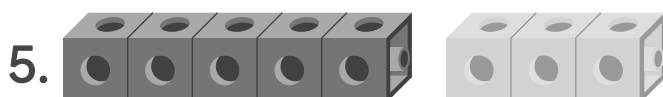

There are cubes.



Check



Count to find the total number of cubes. Then fill in the sentence.

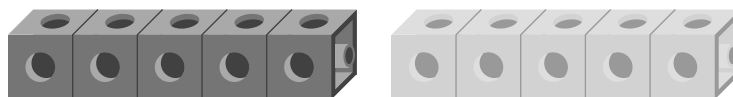

There are cubes.

Counting to Find the Total Number of Pictures

ML 4.03



Modeled Review



Name: Avery

Count the pictures. Then fill in the sentence.



1 2 3 4 5

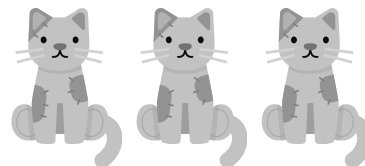

6 7 8

There are 8 altogether.



Guided Practice



Count the pictures. Then fill in the sentence.



There are _____ suns.



There are _____ jars.



There are _____ trucks.



Guided Practice



Count the pictures. Fill in the sentences.

4.



There are _____
_____ altogether.

5.

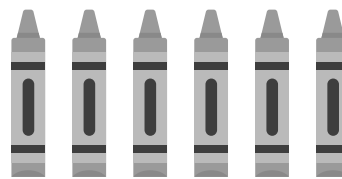
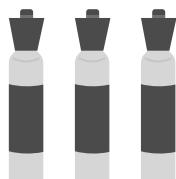

There are _____
_____ altogether.

6.

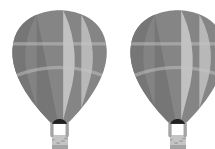
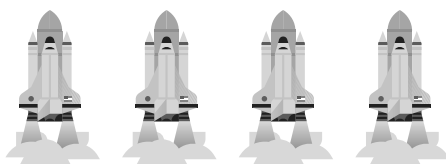

There are _____
_____ altogether.



Check



Count the pictures. Fill in the sentences.



There are _____
_____ altogether.

Counting Organized and Scattered Groups

ML 4.04



Modeled Review



Name: Diego

Count the objects and fill in the sentence.

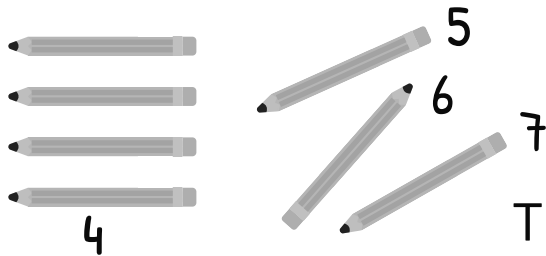

There are 7 pencils.



Guided Practice



Count the objects and fill in the sentence.

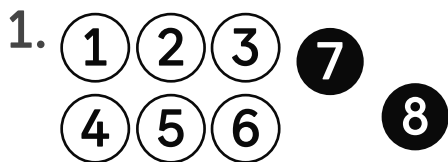

There are _____ dots.

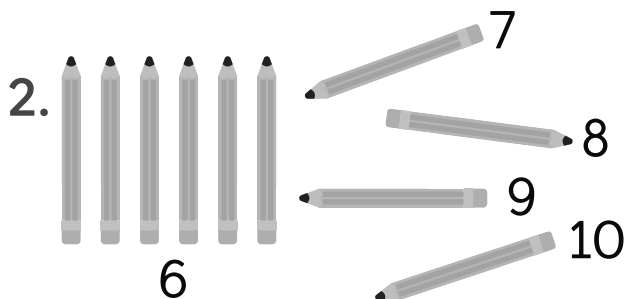

There are _____ pencils.

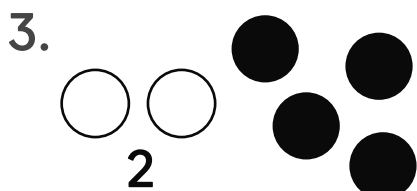

There are _____ dots.



Guided Practice



Count the objects and fill in the sentence.

4.

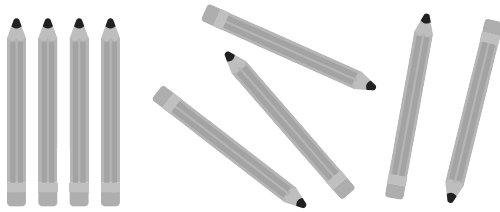

There are _____

_____ pencils.

5.

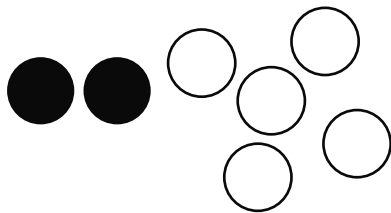

There are _____

_____ dots.

6.

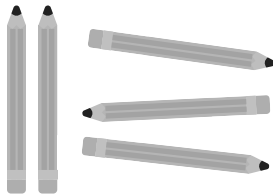

There are _____

_____ pencils.



Check



Count the dots and fill in the sentence.

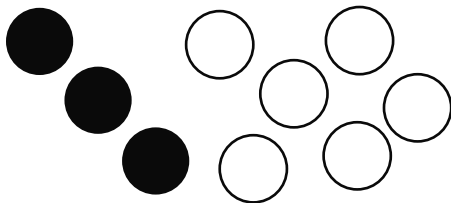

There are _____

_____ dots.

Representing Addition With Objects

ML 4.05



Modeled Review

Name: Eva

Use the 5-frame to show how many counters there are in total. Fill in the sentence.

Start with 5. Add 2 more.



5

There are 7 in total.



6,7



Guided Practice



Write a number to show how many counters there are in total.

1. There are 3. Add 2 more.

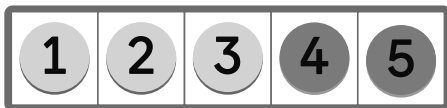

There are 5 in total.

2. There is 1. Add 2 more.



There are _____ in total.

3. There are 3. Add 1 more.



There are _____ in total.



Guided Practice



Use the 5-frame to show how many counters there are in total. Fill in the sentence.

| | | | | |
|--|--|--|--|--|
| | | | | |
|--|--|--|--|--|

4. Start with 3.
Add 3 more.

5. Start with 3.
Add 5 more.

There are in total. There are in total.



Check



Use the 5-frame to show how many counters there are in total. Fill in the sentence.

| | | | | |
|--|--|--|--|--|
| | | | | |
|--|--|--|--|--|

Start with 5. Add 4 more. There are in total.

Representing Subtraction With Objects

ML 4.06



Modeled Review

Name: Avery

Write a number to show how many counters are left. Start with 7 counters. Take away 4 counters.

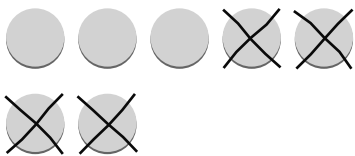

There are 3 counters left.



Guided Practice



Write a number to show how many counters are left.

1. Start with 5 counters. Take away 1 counter.



There are _____ left.

2. Start with 8 counters. Take away 3 counters.

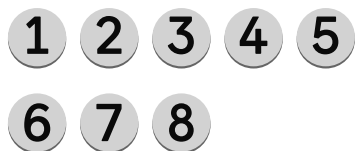

There are _____ left.

3. Start with 6 counters. Take away 4 counters.

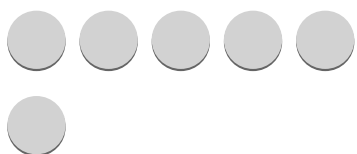

There are _____ left.



Guided Practice



Write a number to show how many counters are left.

4. Start with 10 counters. Take away 4 counters.

There are $\frac{\quad}{\quad}$ left.

5. Start with 8 counters. Take away 7 counters.

There is $\frac{\quad}{\quad}$ left.

6. Start with 7 counters. Take away 3 counters.

There are $\frac{\quad}{\quad}$ left.



Check



Write a number to show how many counters are left.

Start with 9 counters. Take away 2 counters.

There are $\frac{\quad}{\quad}$ left.

Adding and Subtracting in the Real World

ML 4.07



Modeled Review



Name: Jack

How many cars will be in the parking lot? Fill in the sentence.

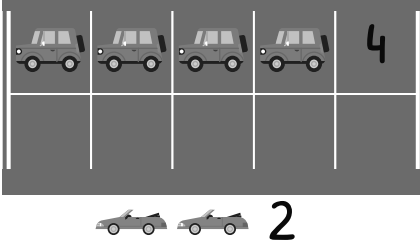
1. 

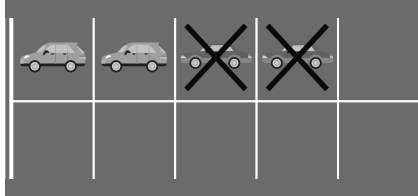
2. 

There will be 6 cars. There will be 2 cars.



Guided Practice

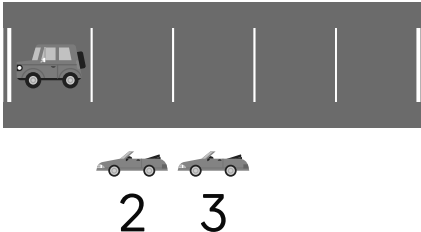

How many cars will be in the parking lot? Fill in the sentence.

1. 

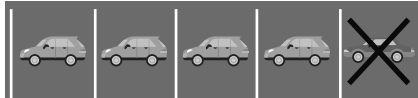
2. 

There will be cars. There will be cars.



Guided Practice



How many cars will be in the parking lot? Fill in the sentence.

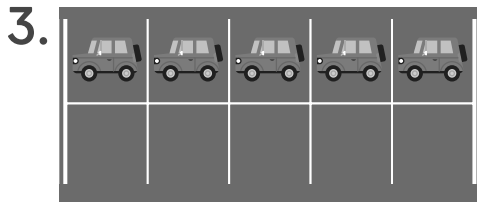

There will be _____ cars.

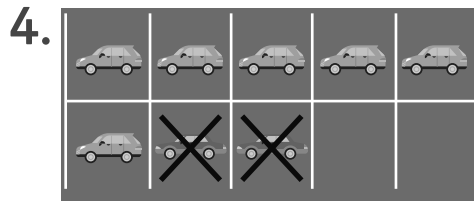

There will be _____ cars.

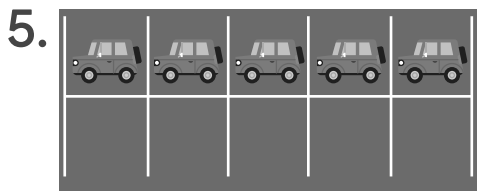

There will be _____ cars.

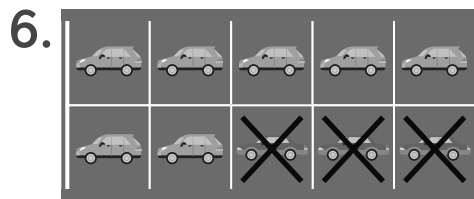

There will be _____ cars.



Check



How many cars will be in the parking lot? Fill in the sentence.

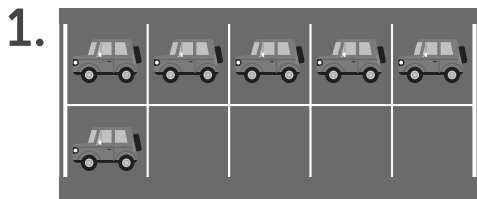

There will be _____ cars.

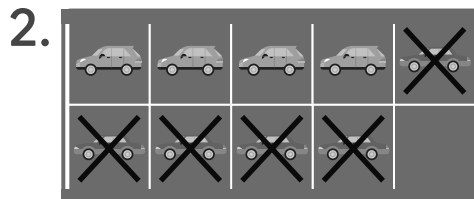

There will be _____ cars.

Telling and Acting Out Math Stories

ML 4.08

**Modeled Review**Name: Kai

Tell a math story that uses numbers to describe what is happening in this picture.

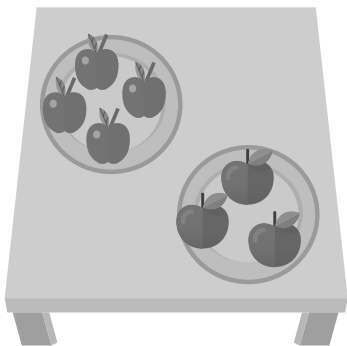

There are 4 green apples on one plate and 3 red apples on one plate.

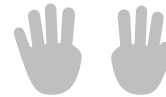
**Guided Practice**

1. Tell a math story that uses numbers to describe what is happening in this picture.

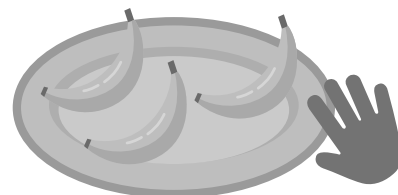
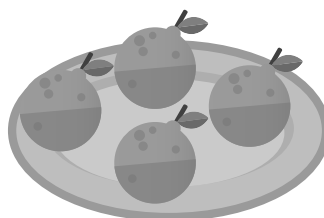
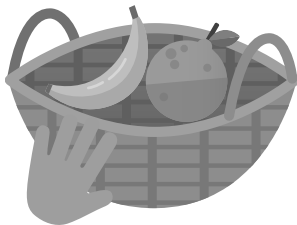



Guided Practice



2. Tell a math story that uses numbers to describe what is happening in the picture.



Check



Tell a math story that uses numbers to describe what is happening in the picture.

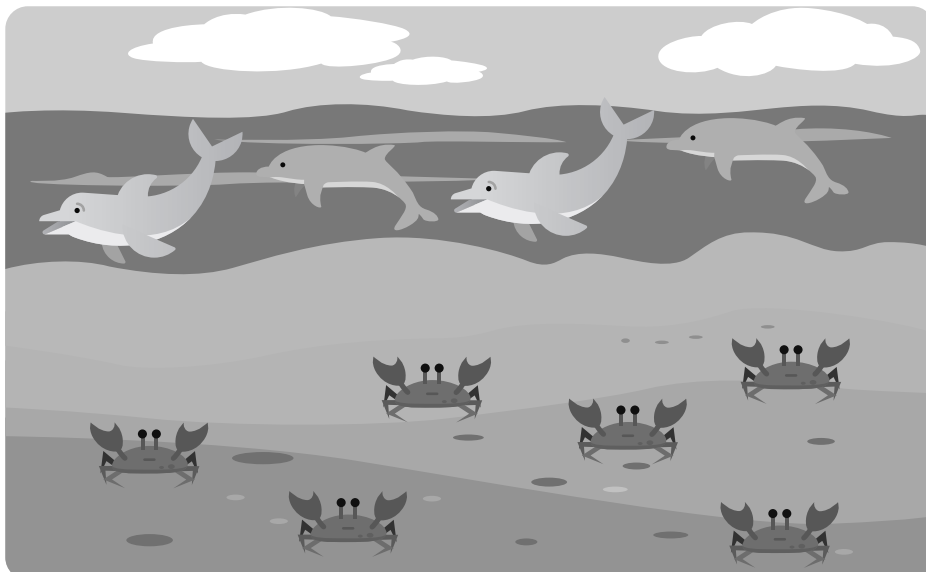

Representing Math Stories With Objects

ML 4.09



Modeled Review

Name: Tristan

Use counters to show what is happening in the story.

There are 4 students playing on the slide.
3 more students decided to join them.

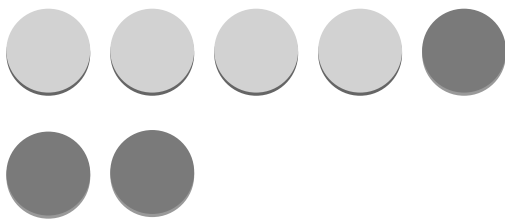

I started with 4 yellow counters. Then I added 3 red counters.



Guided Practice



Use counters to represent what is happening in the story.

1. There are 3 students playing on the slide.
2 more come to play on the slide.

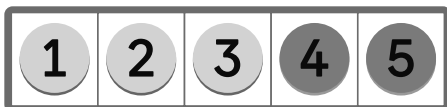

2. There are 4 students waiting to play on the swing. 3 more students joined the line.



Guided Practice



Use counters to show what is happening in the story.

3. There are 5 students playing in the sandbox.
2 students left to play tag.

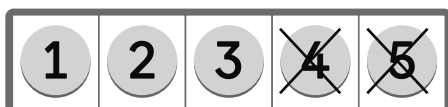

4. There are 5 students waiting in line to play on the swing.
3 students left to play on the slide.

5. There are 6 students playing tag together.
3 students left to play in the sandbox.



Check



Use counters to represent what is happening in the story.

1. There are 6 students playing on the merry-go-round.
4 students left to play in the sandbox.
2. There are 2 students playing on the swings.
3 more come to play on the swings.

Solving Addition Story Problems

ML 4.10



Modeled Review



Name: Santiago

Solve the problem. Show your thinking. Write your answer on the line.

There are 5 squirrels in a tree. 2 more squirrels climb up the tree. How many squirrels are in the tree?



1, 2, 3, 4, 5



6, 7

There are 7 squirrels.



Guided Practice



Solve the problem. Show your thinking using the 5-frame. Write your answer on the line.

1. There are 3 birds in a nest. Then 2 more birds fly into the nest. How many birds are in the nest now?

| | | | | |
|--|--|--|--|--|
| | | | | |
|--|--|--|--|--|

There are _____ birds.



Guided Practice



Solve each problem. Show your thinking. Write your answer on the line.

2. 4 bunnies hopped in the grass. 3 more bunnies joined them. How many bunnies are in the grass?

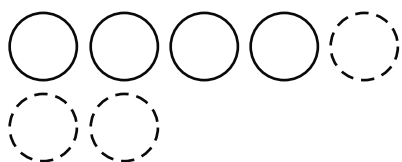

There are
 bunnies.

3. Avery saw 6 ducks swimming in a pond. 2 more ducks came to swim. How many ducks are swimming in the pond now?

There are
 ducks.



Check



Solve the problem. Show your thinking. Write your answer on the line.

Eva collected 5 red leaves. Then she collected 4 yellow leaves. How many leaves did Eva collect?

There are
 leaves.

Solving Subtraction Story Problems

ML 4.11



Modeled Review

Name: Diego

Solve the problem. Show your thinking. Write your answer on the line.

Dylan had 8 pencils. He gave away 3 pencils. How many pencils does Dylan have left?

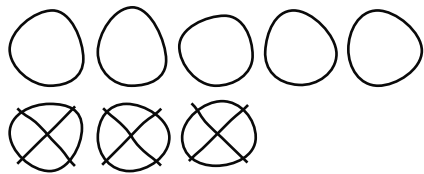

There are 5 pencils.



Guided Practice



Solve the problem. Show your thinking. Write your answer on the line.

- Clare has 5 crayons. She gave 2 crayons to Jack. How many crayons does she have left?

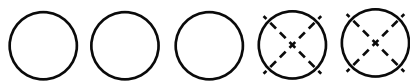

There are crayons.



Guided Practice



Solve each problem. Show your thinking. Write your answer on the line.

2. There were 6 glue sticks on the table. 3 glue sticks rolled off the table. How many glue sticks are left on the table?

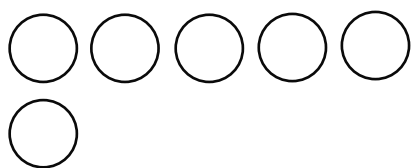

There are
 glue sticks.

3. There were 7 colored pencils in the box. Maya took 3 colored pencils out to use. How many are left in the box?

There are
 colored pencils.



Check



Solve the problem. Show your thinking. Write your answer on the line.

- There were 6 markers in the pack. Han used 4 markers. How many markers are left in the pack?

There are
 markers.

Representing a Story Problem With Drawings

ML 4.12



Modeled Review



There are 4 horses in the barn. 2 *more* came into the barn. How many horses are in the barn?

Jack's work



There are 6 horses in the barn.

Priya's work

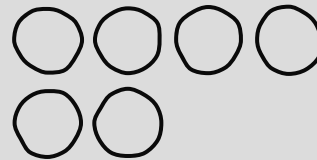

There are 6 horses in the barn.



Guided Practice



Solve the story problem. Show your thinking using counters.

1. There are 3 sheep in the field. 2 more sheep came to the field. How many sheep are in the field?

| | | | | |
|--|--|--|--|--|
| | | | | |
|--|--|--|--|--|

There are sheep in the field.



Guided Practice



Solve the story problem. Show your thinking using drawings.

2. There are 4 cows on the farm. 3 more cows came to the farm. How many cows are on the farm?

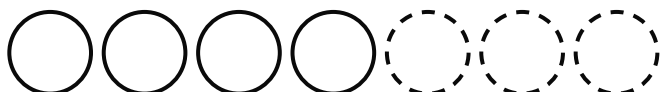

There are cows.

3. There are 2 hens in the henhouse. 6 more hens came to the henhouse. How many hens are in the henhouse?

There are hens.



Check



Solve the story problem. Show your thinking using drawings.

- There are 6 ducks swimming. 3 more ducks come to swim. How many ducks are swimming?

There are ducks swimming.

Drawing to Show Story Problems With Zero

ML 4.13



Modeled Review

Name: Tristan

Solve the story problem. Show your thinking with a drawing.

There were 6 leaves on the tree. 6 leaves fell off. How many leaves are left on the tree?



There are 0 leaves left.



Guided Practice



Solve the story problem. Show your thinking with counters.

1. There were 5 kids playing in the park. 5 kids left the park. How many kids are left playing in the park?

| | | | | |
|--|--|--|--|--|
| | | | | |
|--|--|--|--|--|

There are kids left.



Guided Practice



Solve the story problem. Show your thinking with a drawing.

2. There were 7 acorns. A squirrel ate all 7 acorns. How many acorns are left?



There are acorns left.

3. There were 9 stones on the ground. Jack picked up the 9 stones. How many stones are still on the ground?

There are stones left.



Check



Solve the story problem. Show your thinking with a drawing.

There were 8 birds in a nest. 8 birds flew away. How many birds are left in the nest?

There are birds left.

Creating and Solving Addition and Subtraction Story Problems

ML 4.14



Modeled Review



Name: Maya

Use the picture to tell your own story problem. Solve the problem. Show your thinking in the box.

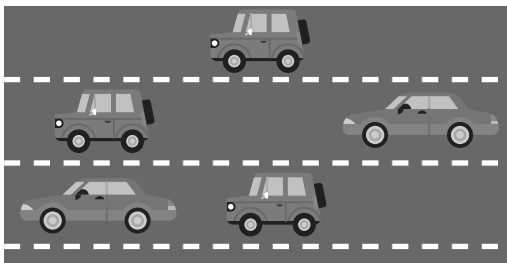

There are 3 green cars and 2 red cars. How many cars are there in total?

$$\begin{array}{r} \\ \hline 5 \\ \hline \end{array}$$



Guided Practice



1. Use the picture to tell your own story problem. Solve the problem. Show your thinking in the box.

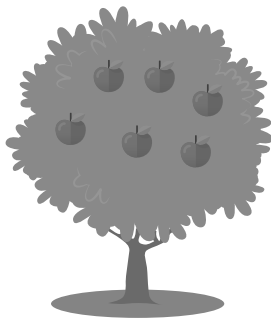

Jack has $\begin{array}{r} \\ \hline 6 \\ \hline \end{array}$ apples.

He ate $\begin{array}{r} \\ \hline \\ \hline \end{array}$ apples.

$\begin{array}{r} \\ \hline \\ \hline \end{array}$ apples



Guided Practice



2. Use the picture to tell your own story problem. Solve the problem. Show your thinking in the box.





Check



Use the picture to tell your own story problem. Solve the problem. Show your thinking in the box.

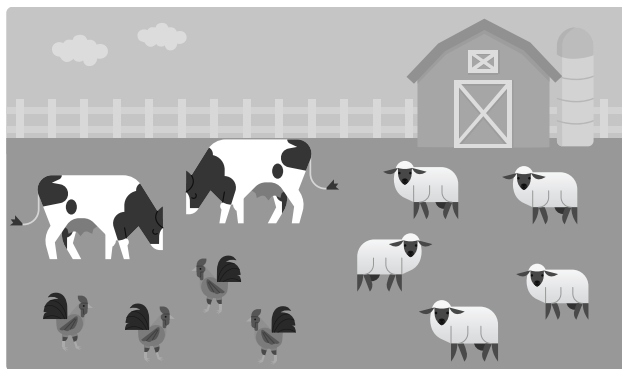



Introducing Expressions

ML 4.15



Modeled Review



| Expression | |
|---|--|
| plus | minus |
| $3 + 2$  add | $5 - 2$  subtract or take away |



Guided Practice



Circle the symbol that matches the drawing.

1. 

| | |
|---|---|
| + | - |
|---|---|

2. 

| | |
|---|---|
| + | - |
|---|---|

3. 

| | |
|---|---|
| + | - |
|---|---|



Guided Practice



Circle the expression that matches the story.

4. There are 6 oranges growing on the tree. Shawn picked 3 oranges. How many oranges are left on the tree?



$$6 + 3$$

$$6 - 3$$

5. Kai used 4 strawberries and 2 bananas for the fruit salad. How many pieces of fruit did Kai use?

$$4 + 2$$

$$4 - 2$$

6. Mr. Patel had 7 peaches in his cart. He added 2 apples. How many pieces of fruit does Mr. Patel have in his cart?

$$7 + 2$$

$$7 - 2$$



Check



Circle the expression that matches the story.

There were 8 pieces of fruit in the bowl. Someone ate 3. How many pieces of fruit are left in the bowl?

$$8 + 3$$

$$8 - 3$$

Representing Story Problems With Expressions

ML 4.16



Modeled Review

Name: Avery

Circle the expression that shows what happened in the story problem.

At the zoo, Kai saw 7 pandas in a tree. Then 2 more climbed into the tree. How many pandas are in the tree?

The story starts with 7 then 2 more are added.

$4 - 2$

$5 + 4$

$7 + 2$



Guided Practice



Circle the expression that shows what happened in the story problem.

- Jada saw 5 flamingos. Then 3 flamingos flew away. How many flamingos are left?



$3 + 4$

$5 - 3$



Guided Practice



Circle the expression that shows what happened in the story problem.

2. Han saw 4 lions at the zoo. Then he saw 2 more lions. How many lions did Han see?

$4 + 2$

$2 + 6$

$8 - 2$

3. Dylan saw 6 butterflies on a plant. 3 more butterflies flew on the plant. How many butterflies are on the plant?

$3 + 3$

$6 + 3$

$6 - 3$

4. Kai saw 8 birds in a tree. 5 birds flew away. How many birds are left?

$8 - 5$

$4 + 3$

$5 + 3$



Check



Circle the expression that shows what happened in the story problem.

Eva saw 7 elephants in the grass. 2 more elephants walked over. How many elephants are in the grass?

$7 - 3$

$6 + 2$

$7 + 2$

Connecting Expressions and Drawings

ML 4.17



Modeled Review



Name: Tristan

Fill in the missing expression or drawing.

| Expression | Drawing |
|-------------------------------|---------|
| $3 - 1$ | |
| $\overline{2} + \overline{2}$ | |



Guided Practice



1. Create a drawing that matches each expression.

| Expression | Drawing |
|------------|---------|
| $3 + 2$ | |
| $6 - 4$ | |
| $5 + 3$ | |
| $7 - 2$ | |



Guided Practice



2. Write an expression that matches the drawing.

| Drawing | Expression |
|---------|------------|
| | |
| | |
| | |
| | |



Check



Fill in the missing expression or drawing.

| Expression | Drawing |
|------------|---------|
| $4 + 2$ | |
| | |

Determining the Value of Expressions

ML 4.18



Modeled Review



Name: Tristan

Find the value of the expression. Use counters or drawings if it is helpful.

7 - 3

4



Guided Practice



Find the value of the expression. Use counters or drawings if it is helpful.

1. 6 - 2

2. 4 + 1



Guided Practice



Find the value of the expression. Use counters or drawings if it is helpful.

$3.7 - 4$

$4.8 - 2$

$5.5 + 2$



Check



Find the value of the expression. Use counters or drawings if it is helpful.

$1. 10 - 2$

$2. 4 + 2$

Adding and Subtracting 0 and 1

ML 4.19



Modeled Review



Name: Eva

Find the value of the expression. Write your answer on the line.

1. $5 + 1 = \underline{\quad 6 \quad}$

2. $4 - 0 = \underline{\quad 4 \quad}$

When I add 1, the number is one more.

When I subtract 0, the number stays the same.



Guided Practice



Find the value of the expression. Write your answer on the line.

1. $4 + 0$



2. $5 - 0$



3. $4 - 1$





Guided Practice



Find the value of the expression. Use counters if it is helpful.

| | | | | |
|--|--|--|--|--|
| | | | | |
|--|--|--|--|--|

$$4.6 + 0 \quad \begin{array}{l} \text{_____} \\ \text{-----} \\ \text{_____} \end{array}$$

$$5.7 + 1 \quad \begin{array}{l} \text{_____} \\ \text{-----} \\ \text{_____} \end{array}$$

$$6.3 - 1 \quad \begin{array}{l} \text{_____} \\ \text{-----} \\ \text{_____} \end{array}$$

$$7.3 - 0 \quad \begin{array}{l} \text{_____} \\ \text{-----} \\ \text{_____} \end{array}$$

$$8.9 - 0 \quad \begin{array}{l} \text{_____} \\ \text{-----} \\ \text{_____} \end{array}$$

$$9.4 + 1 \quad \begin{array}{l} \text{_____} \\ \text{-----} \\ \text{_____} \end{array}$$



Check



Find the value of the expression. Use counters if it is helpful.

$$1.7 + 0 \quad \begin{array}{l} \text{_____} \\ \text{-----} \\ \text{_____} \end{array}$$

$$2.5 - 1 \quad \begin{array}{l} \text{_____} \\ \text{-----} \\ \text{_____} \end{array}$$

Writing Expressions to Represent Story Problems

ML 4.20



Modeled Review

Name: Dylan

Write an expression and find the value for the story problem. Show your thinking with a drawing.

Eva built 2 sandcastles. Then she built 4 more. How many sandcastles did Eva build?

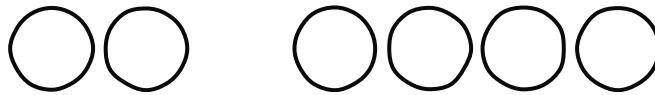

expression: 2 $+$ 4 value: 6



Guided Practice



Write an expression and find the value for the story problem. Show your thinking with a drawing.

- Diego collected 7 seashells. He gave 3 to a friend. How many seashells does Diego have left?

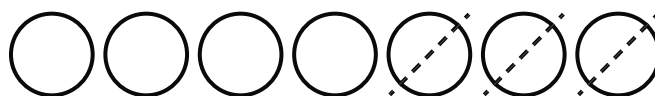

expression: 7 $-$ 3 value:



Guided Practice



Write an expression and find the value for the story problem. Show your thinking with a drawing.

2. Clare had 6 sand toys. She lost 2. How many sand toys does Clare have left?

expression: $\frac{\quad}{\quad} - \frac{\quad}{\quad}$ value: $\frac{\quad}{\quad}$

3. Han saw 4 crabs at the beach. Jada saw 5 crabs. How many crabs did they see altogether?

expression: $\frac{\quad}{\quad} \square \frac{\quad}{\quad}$ value: $\frac{\quad}{\quad}$



Check



Write an expression and find the value for the story problem. Show your thinking with a drawing.

- 8 friends are playing on the beach. 5 went home. How many friends are still on the beach?

expression: $\frac{\quad}{\quad} \square \frac{\quad}{\quad}$ value: $\frac{\quad}{\quad}$

Unit 5

Mini-Lessons

Putting Together and Breaking Apart Numbers

ML 5.02



Modeled Review



Name: Maya

Color the circles to represent how you broke apart the given number. Then write an expression to match.

| Number | Circles | Expression |
|--------|---------|---|
| 7 | | $\overline{\underline{4}} + \overline{\underline{3}}$ |



Guided Practice



Write numbers to show how many of each shape were used and how many shapes there are altogether.

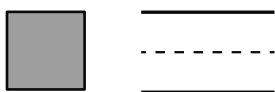
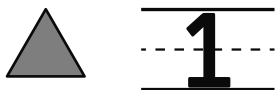
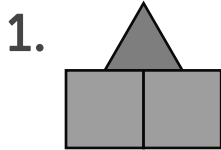

_____ altogether

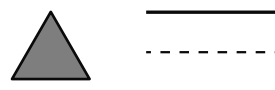
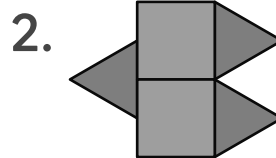

_____ altogether



Guided Practice



3. Color the circles to represent how you broke apart the given number. Then write an expression to match.

| Number | Circles | Expression |
|--------|---------|---------------------------------|
| 6 | | _____ + _____ ----- _____ |
| 8 | | _____ + _____ ----- _____ |
| 7 | | _____ + _____ ----- _____ |



Check



Color the circles to represent how you broke apart the given number. Then write an expression to match.

| Number | Circles | Expression |
|--------|---------|---------------------------------|
| 9 | | _____ + _____ ----- _____ |

Breaking Numbers Apart in More Than One Way

ML 5.03



Modeled Review



Name: Tristan

Break apart 9 in two different ways. Show your thinking with drawings and expressions.

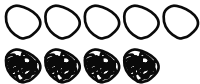
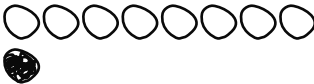



| Number | One way | Another way |
|--------|--|--|
| 9 |  $\begin{array}{r} \underline{5} \\ \text{---} \\ \text{---} \\ \text{---} \\ \text{---} \end{array} + \begin{array}{r} \underline{4} \\ \text{---} \\ \text{---} \\ \text{---} \\ \text{---} \end{array}$ |  $\begin{array}{r} \underline{8} \\ \text{---} \\ \text{---} \\ \text{---} \\ \text{---} \end{array} + \begin{array}{r} \underline{1} \\ \text{---} \\ \text{---} \\ \text{---} \\ \text{---} \end{array}$ |



Guided Practice

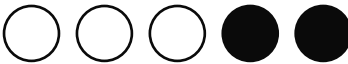

1. Break apart the given number in two different ways. Show your thinking with expressions.





| Number | One way | Another way |
|--------|--|--|
| 3 |  $\begin{array}{r} \underline{2} \\ \text{---} \\ \text{---} \\ \text{---} \\ \text{---} \end{array} + \begin{array}{r} \underline{\quad} \\ \text{---} \\ \text{---} \\ \text{---} \\ \text{---} \end{array}$ |  $\begin{array}{r} \underline{\quad} \\ \text{---} \\ \text{---} \\ \text{---} \\ \text{---} \end{array} + \begin{array}{r} \underline{\quad} \\ \text{---} \\ \text{---} \\ \text{---} \\ \text{---} \end{array}$ |
| 5 |  $\begin{array}{r} \underline{\quad} \\ \text{---} \\ \text{---} \\ \text{---} \\ \text{---} \end{array} + \begin{array}{r} \underline{\quad} \\ \text{---} \\ \text{---} \\ \text{---} \\ \text{---} \end{array}$ |  $\begin{array}{r} \underline{\quad} \\ \text{---} \\ \text{---} \\ \text{---} \\ \text{---} \end{array} + \begin{array}{r} \underline{\quad} \\ \text{---} \\ \text{---} \\ \text{---} \\ \text{---} \end{array}$ |



Guided Practice



2. Break apart the given number in two different ways. Show your thinking with drawings and expressions.

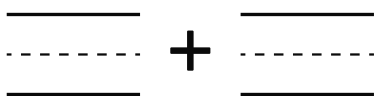

| Number | One way | Another way |
|--------|--|--|
| 4 |   |  |
| 6 |  |  |



Check



Break apart 8 in two different ways. Show your thinking with drawings and expressions.

| Number | One way | Another way |
|--------|---|--|
| 8 |  |  |

Matching Equations and Drawings

ML 5.04



Modeled Review



Name: Jada

Write an equation to represent the drawing.

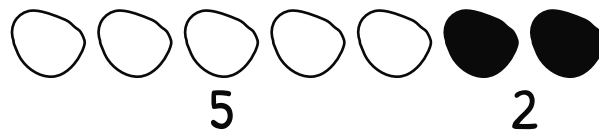

$$\underline{7} = \underline{5} + \underline{2}$$



Guided Practice



1. Draw a line to match the drawing with the equation that represents it.

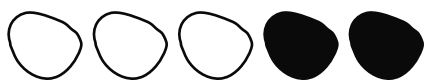

$8 = 3 + 5$



$4 = 2 + 2$



$5 = 3 + 2$



$7 = 1 + 6$



Guided Practice



Write an equation to represent the drawing.

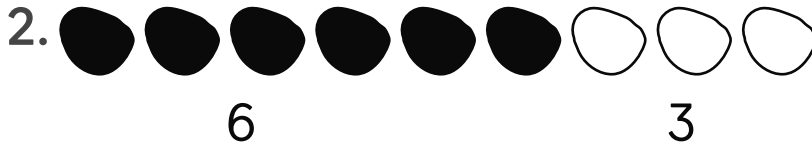

$$\begin{array}{c} \text{---} \\ \text{---} \\ \text{---} \\ \text{---} \end{array} = 6 + 3$$



$$\begin{array}{c} \text{---} \\ \text{---} \\ \text{---} \\ \text{---} \end{array} = \begin{array}{c} \text{---} \\ \text{---} \\ \text{---} \\ \text{---} \end{array} + \begin{array}{c} \text{---} \\ \text{---} \\ \text{---} \\ \text{---} \end{array}$$



$$\begin{array}{c} \text{---} \\ \text{---} \\ \text{---} \\ \text{---} \end{array}$$



Check



Write an equation to represent the drawing.



$$\begin{array}{c} \text{---} \\ \text{---} \\ \text{---} \\ \text{---} \end{array}$$

Breaking Apart Numbers in Many Ways

ML 5.05



Modeled Review



Name: Han

Break apart 5 in three different ways.

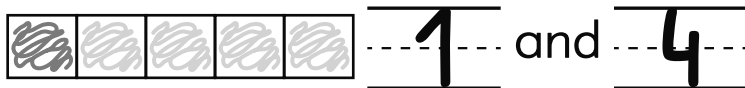

I colored another square red each time. It made a pattern!



Guided Practice



1. Circle all the representations of 6.



$3 + 3$



$4 + 1$



$2 + 2$

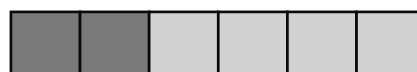

$2 + 4$



Guided Practice



Break apart each number in three different ways.

2.8



4 and _____



_____ and _____

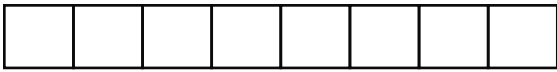

_____ and _____

3.7

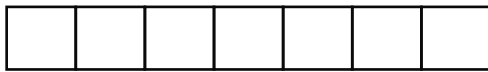

_____ and _____



_____ and _____



_____ and _____



Check



Break 9 apart in three different ways.

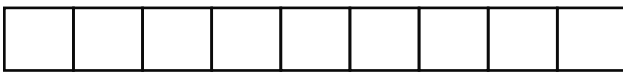

_____ and _____

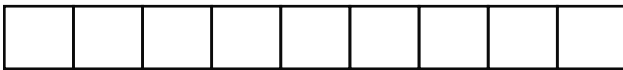

_____ and _____

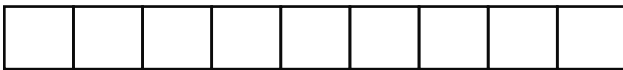

_____ and _____

Making Sense of Math Stories

ML 5.06



Modeled Review

Name: Clare

Use drawings, numbers, and words to show the math story. You can use objects if they are helpful.

There are 8 crayons in the box.
Some are green and some are blue.



4

4



Guided Practice



Use drawings, numbers, and words to show the math story. You can use objects if they are helpful.

- There are 6 markers.
Some are red and some are yellow.



3 red yellow



Guided Practice



Use drawings, numbers, and words to show the math story. You can use objects if they are helpful.

2. There are 5 pieces of fruit.

Some are apples and some are bananas.

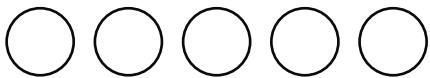

_____ apples _____ bananas

3. There are 9 students playing.

Some are playing with cars and some are playing with blocks.

_____ _____



Check



Use drawings, numbers, and words to show the math story. You can use objects if they are helpful.

There are 7 books.

Some are about cats and some are about dogs.

_____ _____

Solving and Writing Equations for Story Problems

ML 5.07



Modeled Review

Name: Jack

Solve the story problem. Show your thinking using a drawing. Fill in the equation to match your work.

There are 7 pieces of fruit. Some are blueberries and some are strawberries. How many of each could there be?



$$7 = \underline{4} + \underline{3}$$



Guided Practice



Solve the story problem. Show your thinking using a drawing. Fill in the equation to match your work.

- There are 5 vegetables. Some are cucumbers and some are carrots. How many of each could there be?



$$5 = \underline{3} + \underline{\quad}$$



Guided Practice



Solve the story problem. Show your thinking using a drawing. Fill in the equation to match your work.

2. There are 6 pieces of fruit. Some are apples and some are bananas. How many of each could there be?



$$6 = \underline{\quad} + \underline{\quad}$$

3. There are 7 vegetables. Some are potatoes and some are corn. How many of each could there be?

$$7 = \underline{\quad} + \underline{\quad}$$



Check



Solve the story problem. Show your thinking using a drawing. Fill in the equation to match your work.

There are 8 pieces of fruit. Some are peaches and some are pears. How many of each could there be?

$$8 = \underline{\quad} + \underline{\quad}$$

Finding More Than One Answer to a Story Problem

ML 5.08



Modeled Review



Name: Avery

Solve the story problem in *two* ways. Use drawings to show your thinking.

There are 8 toy cars. Some are green and the rest are blue. How many of each color could there be?

| Answer 1 | Answer 2 |
|----------|----------|
| | |
| | |

I drew 8 circles first, then found two different answers.



Guided Practice



Solve the story problem in *two* ways. Color the circles to show your thinking.

- There are 6 toy trains. Some are red and the rest are blue. How many of each could there be?

| Answer 1 | Answer 2 |
|----------|----------|
| | |
| | |



Guided Practice



Solve the story problem in *two* ways. Use drawings to show your thinking.

2. There are 5 stickers. Some are pink and the rest are yellow. How many of each could there be?

| Answer 1 | Answer 2 |
|-----------|-----------|
| ○ ○ ○ ○ ○ | ○ ○ ○ ○ ○ |

3. There are 9 pattern blocks. Some are green and the rest are orange. How many of each could there be?

| Answer 1 | Answer 2 |
|----------|----------|
| | |



Check



Solve the story problem in *two* ways. Use drawings to show your thinking.

- There are 7 blocks. Some are red and the rest are green. How many of each could there be?

| Answer 1 | Answer 2 |
|----------|----------|
| | |

Representing and Solving Story Problems

ML 5.09



Modeled Review

Name: Dylan

Solve the problem. Show your thinking. Fill in the equation to match your work.

There are 6 ducks in the pond and 3 on the grass. How many ducks are there?

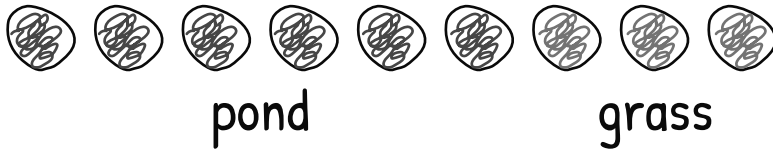

$$\underline{\quad 9 \quad} = 6 + 3$$



Guided Practice



Solve the problem. Show your thinking. Fill in the equation to match your work.

- There are 4 blue fish and 2 red fish in the pond. How many fish are there?

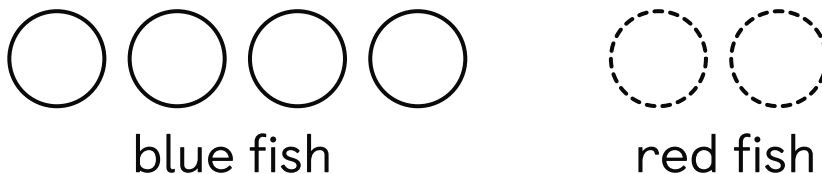

$$\underline{\quad 6 \quad} = 4 + 2$$



Guided Practice



Solve the problem. Show your thinking. Fill in the equation to match your work.

2. There are 2 red birds and 5 yellow birds in the tree. How many birds are there?

$$\begin{array}{r} \underline{\quad} \\ \text{-----} \\ \underline{\quad} \end{array} = 2 + 5$$

3. There are 6 baby squirrels and 2 adult squirrels. How many squirrels are there?

$$\begin{array}{r} \underline{\quad} \\ \text{-----} \\ \underline{\quad} \end{array} = 6 + 2$$



Check



Solve the problem. Show your thinking. Fill in the equation to match your work.

There are 5 turtles swimming and 4 on the grass. How many turtles are there?

$$\begin{array}{r} \underline{\quad} \\ \text{-----} \\ \underline{\quad} \end{array} = 5 + 4$$

Writing Equations to Represent Story Problems

ML 5.10



Modeled Review



Name: Shawn

Write an equation to represent the story problem. Use drawings or counters if it is helpful.

There were 7 zebras in the grass. 3 zebras walked away. How many zebras are left?

4 = 7 - 3 ○○○○○~~○~~~~○~~~~○~~



Guided Practice



Write an equation to represent the story problem.

1. There are 5 adult giraffes and 2 baby giraffes. How many giraffes are there?

○○○○○ ○○ _____ = 5 + 2

2. There are 6 lions on the rock. 4 jumped off the rock. How many lions are still on the rock?

○○○○○○ _____ = _____ - _____



Guided Practice



Write an equation to represent the story problem.
Use drawings or counters if it is helpful.

3. There are 8 flamingos in the water. 3 left the water. How many flamingos are still in the water?

$$\begin{array}{c} \underline{\quad\quad} \\ \text{-----} \\ \underline{\quad\quad} \end{array} = \begin{array}{c} \underline{\quad\quad} \\ \text{-----} \\ \underline{\quad\quad} \end{array} - \begin{array}{c} \underline{\quad\quad} \\ \text{-----} \\ \underline{\quad\quad} \end{array}$$

4. There are 3 monkeys in the tree. 7 more climb the tree. How many monkeys are in the tree?

$$\begin{array}{c} \underline{\quad\quad} \\ \text{-----} \\ \underline{\quad\quad} \end{array} = \begin{array}{c} \underline{\quad\quad} \\ \text{-----} \\ \underline{\quad\quad} \end{array} \square \begin{array}{c} \underline{\quad\quad} \\ \text{-----} \\ \underline{\quad\quad} \end{array}$$

5. There are 9 gorillas in the tree. 2 climbed out of the tree. How many gorillas are still in the tree?

$$\begin{array}{c} \underline{\quad\quad} \\ \text{-----} \\ \underline{\quad\quad} \end{array} = \begin{array}{c} \underline{\quad\quad} \\ \text{-----} \\ \underline{\quad\quad} \end{array} \square \begin{array}{c} \underline{\quad\quad} \\ \text{-----} \\ \underline{\quad\quad} \end{array}$$



Check



Write an equation to represent the story problem.
Use drawings or counters if it is helpful.

- There are 4 elephants. 5 more came to join them. How many elephants are there now?

$$\begin{array}{c} \underline{\quad\quad} \\ \text{-----} \\ \underline{\quad\quad} \end{array} = \begin{array}{c} \underline{\quad\quad} \\ \text{-----} \\ \underline{\quad\quad} \end{array} \square \begin{array}{c} \underline{\quad\quad} \\ \text{-----} \\ \underline{\quad\quad} \end{array}$$

Showing Numbers on a 10-Frame

ML 5.11



Modeled Review

Name: Priya

Use counters to show 8 on the 10-frame.

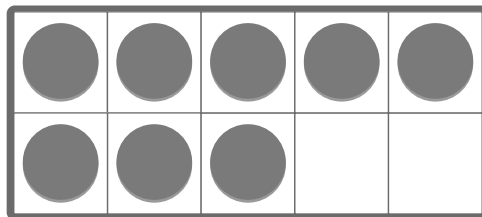

Guided Practice



1. Draw a line to match the number with the 10-frame that represents it.

6

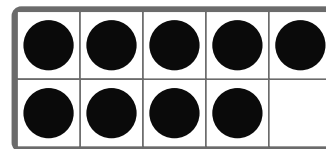

4

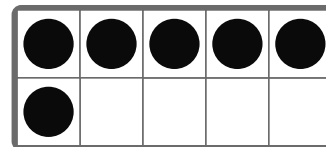

9

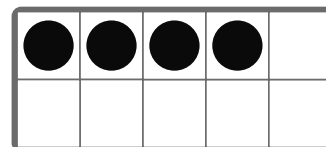



Guided Practice



Use counters to show the given number on the 10-frame.

| | | | | |
|--|--|--|--|--|
| | | | | |
| | | | | |

2.

| | | | | |
|---|---|---|---|---|
| ○ | ○ | ○ | ○ | ○ |
| ○ | ○ | | | |

3.

6

4.

5

5.

8



Check



Use counters to show the given number on the 10-frame.

| | | | | |
|--|--|--|--|--|
| | | | | |
| | | | | |

1.

4

2.

9

Breaking Apart 10

ML 5.12



Modeled Review



Name: Diego

Use counters to show the equation $10 = 5 + 5$ on the 10-frame.

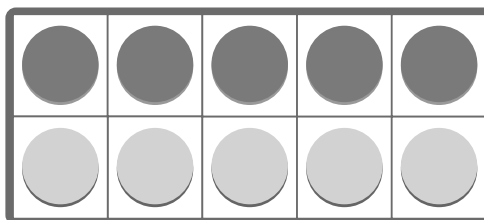
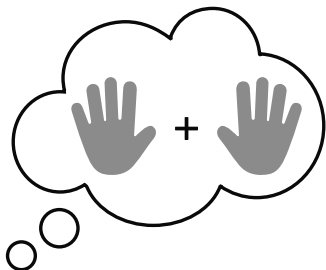

Guided Practice



1. Draw a line to match each equation with the 10-frame.

$10 = 6 + 4$

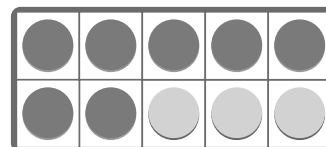

$10 = 7 + 3$



$10 = 1 + 9$

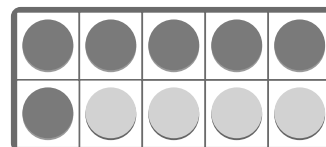



Guided Practice



Use counters to show the equations on the 10-frame.

| | | | | |
|--|--|--|--|--|
| | | | | |
| | | | | |

2. $10 = 5 + 5$

3. $10 = 3 + 7$

4. $10 = 9 + 1$

5. $10 = 8 + 2$



Check



Use counters to show the equations on the 10-frame.

| | | | | |
|--|--|--|--|--|
| | | | | |
| | | | | |

1. $10 = 2 + 8$

2. $10 = 4 + 6$

Finding Number Pairs That Make 10

ML 5.13



Modeled Review



Name: Kai

Write an equation to show how many more to make 10.

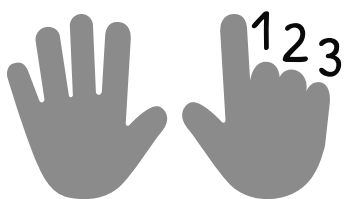

$$10 = \underline{7} + \underline{3}$$



Guided Practice



Write an equation to show how many more to make 10.

1.

| | | | | |
|---|---|---|---|---|
| ● | ● | ● | ● | ● |
| ● | ○ | ○ | ○ | ○ |

$$10 = \underline{6} + \underline{4}$$

2.

| | | | | |
|---|---|---|---|---|
| ● | ● | ● | ● | ● |
| | | | | |

$$10 = \underline{5} + \underline{\quad}$$

3.

| | | | | |
|---|---|---|--|--|
| ● | ● | ● | | |
| | | | | |

$$10 = \underline{\quad} + \underline{\quad}$$



Guided Practice



Write an equation to show how many more to make 10.

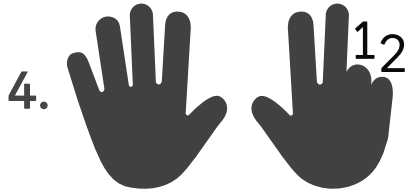

$$10 = \underline{8} + \underline{\quad}$$

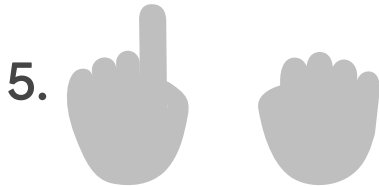

$$10 = \underline{1} + \underline{\quad}$$

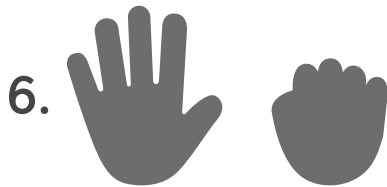

$$10 = \underline{\quad} + \underline{\quad}$$

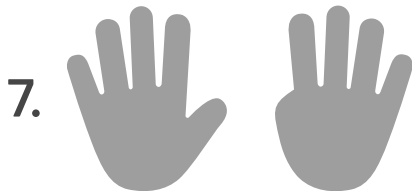

$$10 = \underline{\quad} + \underline{\quad}$$



Check



Write an equation to show how many more to make 10.

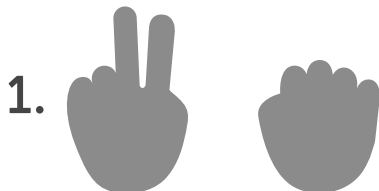

$$10 = \underline{\quad} + \underline{\quad}$$

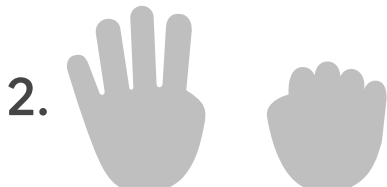

$$10 = \underline{\quad} + \underline{\quad}$$

Writing Equations to Make 10

ML 5.14



Modeled Review



Name: Eva

How many more are needed to make 10?
Write an equation to show the two parts that make 10.

| Number | Equation |
|--------|--------------------------------------|
| 6 | $10 = \underline{6} + \underline{4}$ |

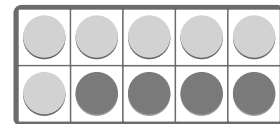

Guided Practice



1. Match the 10-frame to the number needed to make 10.

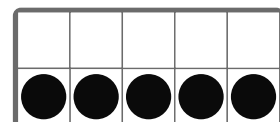
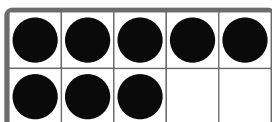
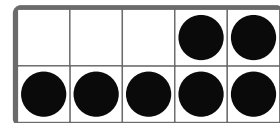
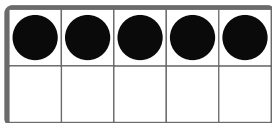
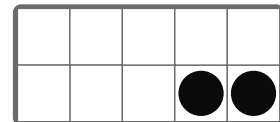
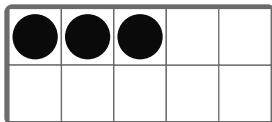



Guided Practice



2. How many more are needed to make 10? Write an equation to show the two parts that make 10.

| Number | Expression |
|--------|--|
| 4 | $10 = 4 + \underline{\quad\quad}$ |
| 9 | $10 = \underline{\quad\quad} + \underline{\quad\quad}$ |
| 2 | $10 = \underline{\quad\quad} + \underline{\quad\quad}$ |
| 3 | $10 = \underline{\quad\quad} + \underline{\quad\quad}$ |
| 0 | $10 = \underline{\quad\quad} + \underline{\quad\quad}$ |
| 5 | $10 = \underline{\quad\quad} + \underline{\quad\quad}$ |



Check



How many more are needed to make 10? Write an equation to show the two parts that make 10.

| Number | Expression |
|--------|--|
| 7 | $10 = \underline{\quad\quad} + \underline{\quad\quad}$ |
| 8 | $10 = \underline{\quad\quad} + \underline{\quad\quad}$ |

Breaking Apart 10 in More Than One Way

ML 5.15



Modeled Review



Name: Santiago

Break apart 10 in *three* different ways.



1 and 9



2 and 8



3 and 7



Guided Practice



Write the number pair that makes 10.



4 and 6



5 and 5



6 and 4



7 and 3



Guided Practice



Break apart 10 in *five* different ways.

5.

 and 

6.

 and 

7.

 and 

8.

 and 

9.

 and 



Check



Break apart 10 in *three* different ways.

1.

 and 

2.

 and 

3.

 and 

Unit 6

Mini-Lessons

Counting Larger Groups of Objects

ML 6.02



Modeled Review



Name: Diego

Move the cubes to the 10-frame. Count to find out how many.

1, 2, 3, 4, 5

6, 7, 8, 9, 10

11, 12, 13.
13 cubes!



Guided Practice



Count the cubes.

1.

2.



Guided Practice



For Problems 3–6, use counters to show the given number on the 10-frame.

| | | | | |
|--|--|--|--|--|
| | | | | |
| | | | | |

3. 11

4. 15

5. 18

6. 19



Check



Use the 10-frame above to show the given numbers.

1. 12

2. 17

Finding How Many When Objects are Rearranged

ML 6.03



Modeled Review



The same group of 14 counters has been rearranged in *three* different ways.

| | | |
|-----------|----------------|-------------|
| <p>14</p> | <p>7 7</p> | <p>10 4</p> |
|-----------|----------------|-------------|



Guided Practice



How many are there? Explain how you know.

1.

2.

3.

4.



Guided Practice



How many are there? Explain how you know.

5.

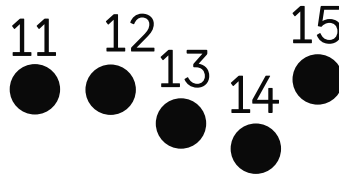
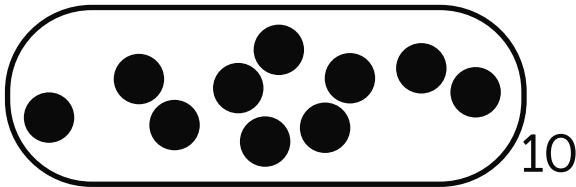

6.

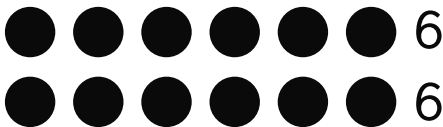

7.

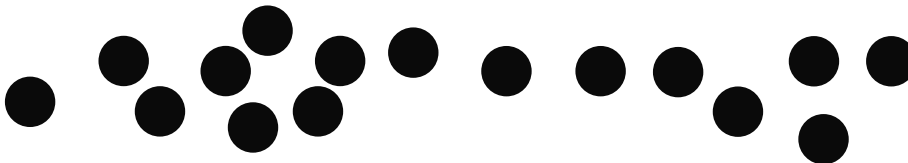

8.

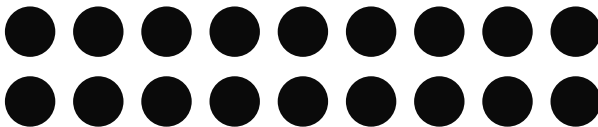

Check



How many are there? Explain how you know.

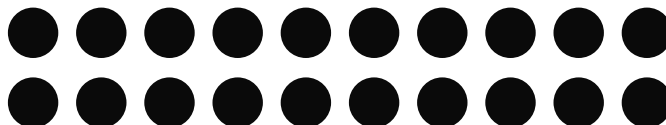

Showing Teen Numbers on Fingers and 10-Frames

ML 6.04



Modeled Review



Jada and Santiago showed 15.

Jada



10 fingers
+ 5 more.

Santiago

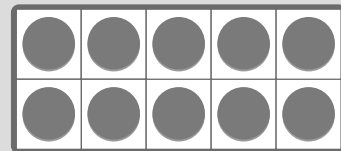

10 counters + 5
more.



Guided Practice



1. Draw a line to match the fingers and 10-frame that show the same number.

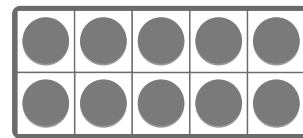
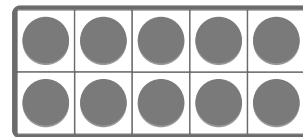
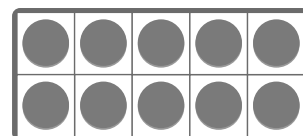



Guided Practice



Draw circles to show the given number on the 10-frame.

2. 12

| | | | | |
|--|--|--|--|--|
| | | | | |
| | | | | |

3. 15

| | | | | |
|--|--|--|--|--|
| | | | | |
| | | | | |

4. 18

| | | | | |
|--|--|--|--|--|
| | | | | |
| | | | | |

5. 14

| | | | | |
|--|--|--|--|--|
| | | | | |
| | | | | |



Check



Draw circles to show the given number on the 10-frame.

1. 17

| | | | | |
|--|--|--|--|--|
| | | | | |
| | | | | |

2. 13

| | | | | |
|--|--|--|--|--|
| | | | | |
| | | | | |

Matching Fingers and 10-Frames to Written Numbers

ML 6.05



Modeled Review



Name: Priya

Circle the number that shows how many fingers or dots.

1. 10 4

13 14 18

2. 10

15 10 11



Guided Practice



1. Draw a line to the number that shows how many fingers or dots.

10 15 16 17 18 16

12

10 2 18



Guided Practice



Circle the number that shows how many fingers or dots.

2.

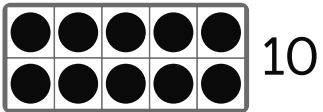

13

15

12

11 12

3.



17

16

19

4.

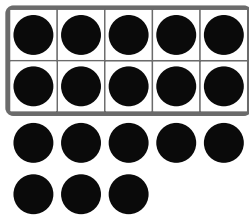

13

17

18

5.



14

11

12



Check



Circle the number that shows how many.

1.



19

15

12

2.

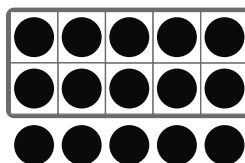

14

17

15

Counting Larger Groups of Images

ML 6.06



Modeled Review



Name: Clare

Count to find the total number of dots. Then write the total.

I circled 10 first, then counted the rest. 10 and 4 is 14!

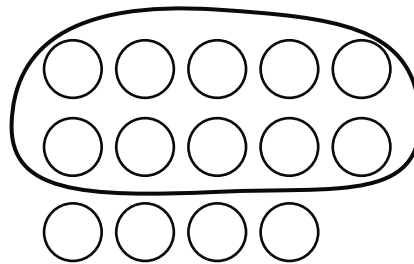

14



Guided Practice



1. Draw lines to match each group with the written number that represents it.

- ① ② ③ ④ ⑤
- ⑥ ⑦ ⑧ ⑨ ⑩
- ⑪ ⑫ ⑬ ⑭ ⑮

12

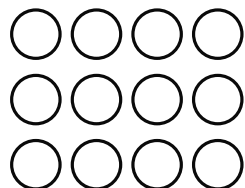

15



Guided Practice

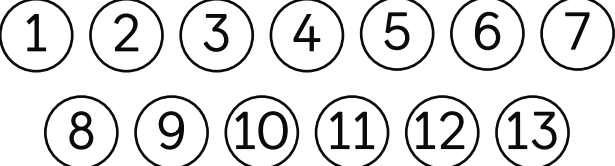

Count to find the total number of dots. Then write the total.

2. 

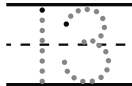

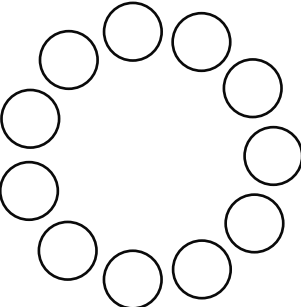
3. 

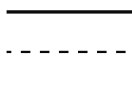

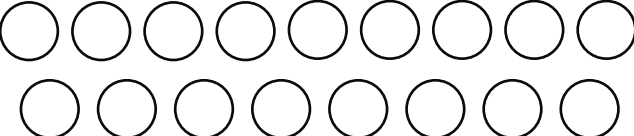
4. 





Check

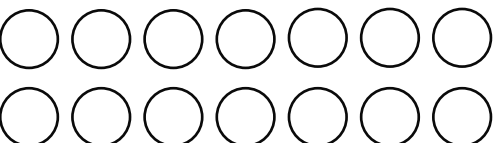

Count to find the total number of dots. Then write the total.

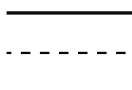
1. 

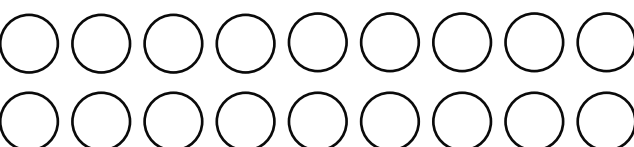

2. 

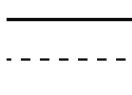

Making Teen Numbers With 10 and Some Ones

ML 6.07



Modeled Review



Name: Han

Add the number on the card to the counters on the 10-frame. Then, write the total number.

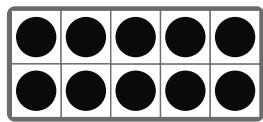

6

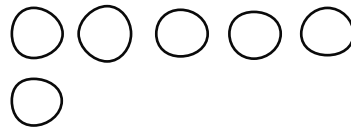

16

10

11, 12, 13, 14, 15, 16



Guided Practice

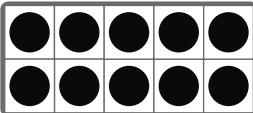

Write the total number of counters.

1. 10 11 12 13 14 15 _____
 ● ● ● ● ● - - - -

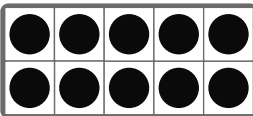
2. 10 _____
 ● ● - - - -

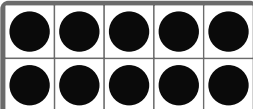
3. _____
 ● ● ● ● ● - - - -



Guided Practice



Add the number on the card to the counters on the 10-frame. Then, write the total number.

4.

10

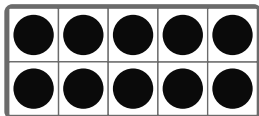

4

11 12 13 14



5.

10

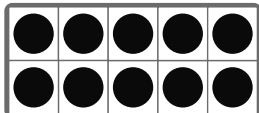

3

6.

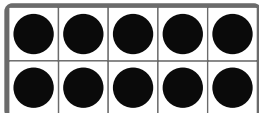

1

7.

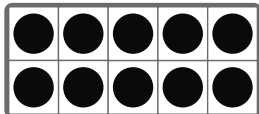

9



Check



Add the number on the card to the counters on the 10-frame. Then, write the total number.

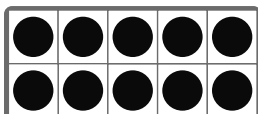

7

Breaking Apart Teen Numbers Into 10 and Some Ones

ML 6.08



Modeled Review



Name: Maya

Draw circles to show 16 on the 10-frame.

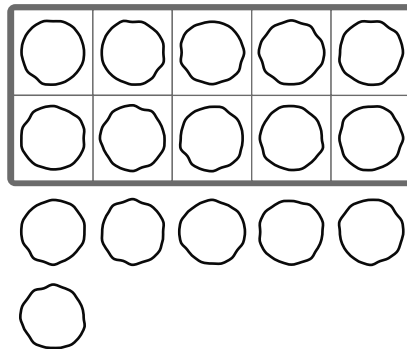

Guided Practice



Draw circles to show the teen number on the 10-frame.

1. 13

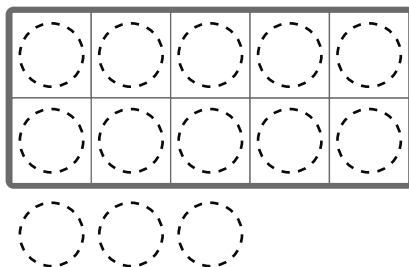

2. 17

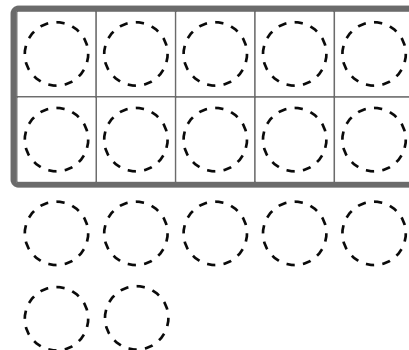



Guided Practice



Draw circles to show the teen number on the 10-frame.

3. 12

| | | | | |
|--|--|--|--|--|
| | | | | |
| | | | | |

4. 15

| | | | | |
|--|--|--|--|--|
| | | | | |
| | | | | |

5. 18

| | | | | |
|--|--|--|--|--|
| | | | | |
| | | | | |

6. 11

| | | | | |
|--|--|--|--|--|
| | | | | |
| | | | | |



Check



Draw circles to show the teen number on the 10-frame.

1. 14

| | | | | |
|--|--|--|--|--|
| | | | | |
| | | | | |

2. 19

| | | | | |
|--|--|--|--|--|
| | | | | |
| | | | | |

Matching Teen Numbers on 10-Frames to Expressions

ML 6.09



Modeled Review



Name: Shawn

Circle the expression that matches the 10-frame.

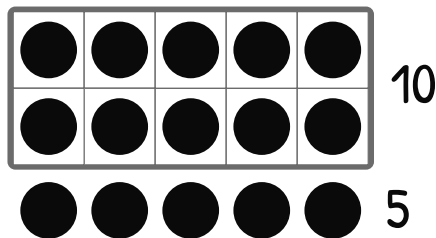

$10 + 2$

$10 + 5$

$10 + 7$



Guided Practice



Fill in the expression to show how many dots there are.

1.

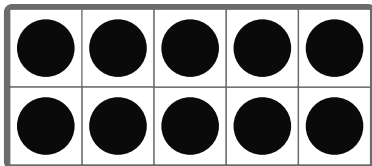

 + 2

2.

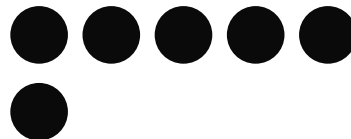
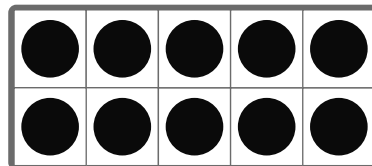

10 +



Guided Practice



Circle the expression that matches the 10-frame.

3.

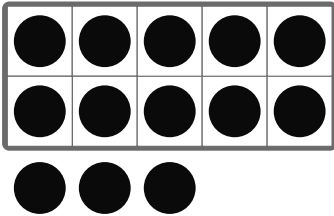

$10 + 3$

$10 + 6$

$10 + 8$

4.

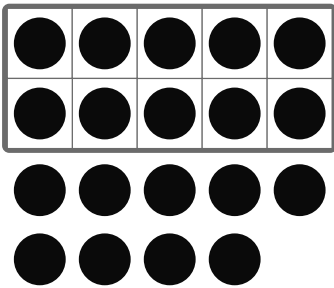

$10 + 7$

$10 + 9$

$10 + 5$

5.

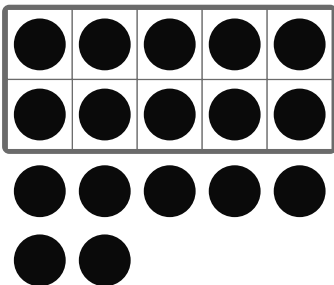

$10 + 7$

$10 + 6$

$10 + 1$



Check



Circle the expression that matches the 10-frame.

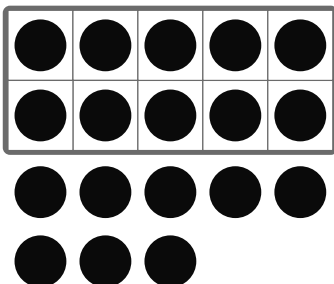

$10 + 4$

$10 + 6$

$10 + 8$

Writing Equations to Show Teen Numbers

ML 6.10



Modeled Review

Name: Jack

Use the 10 plus ones structure to fill in the numbers that make the equation true.

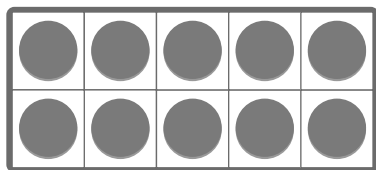

10

$$\underline{10} + \underline{3} = 13$$



3



Guided Practice



Use the 10 plus ones structure to fill in the numbers that make each equation true.

1.

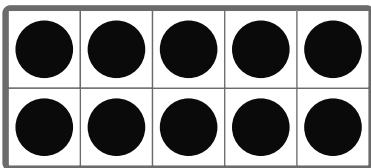

$$10 + \underline{\quad} = 14$$

2.

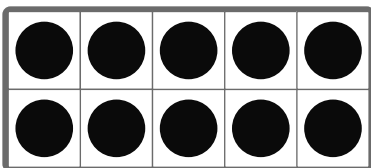

$$\underline{\quad} + \underline{\quad} = 12$$



Guided Practice



Use the 10 plus ones structure to fill in the numbers that make each equation true. Use drawings or counters if it is helpful.

$$3. \begin{array}{c} \underline{\quad} \\ \text{-----} \\ \underline{\quad} \end{array} + \begin{array}{c} \underline{\quad} \\ \text{-----} \\ \underline{\quad} \end{array} = 11$$

$$4. \begin{array}{c} \underline{\quad} \\ \text{-----} \\ \underline{\quad} \end{array} + \begin{array}{c} \underline{\quad} \\ \text{-----} \\ \underline{\quad} \end{array} = 19$$

$$5. \begin{array}{c} \underline{\quad} \\ \text{-----} \\ \underline{\quad} \end{array} + \begin{array}{c} \underline{\quad} \\ \text{-----} \\ \underline{\quad} \end{array} = 15$$

$$6. \begin{array}{c} \underline{\quad} \\ \text{-----} \\ \underline{\quad} \end{array} + \begin{array}{c} \underline{\quad} \\ \text{-----} \\ \underline{\quad} \end{array} = 17$$



Check



Use the 10 plus ones structure to fill in the numbers that make each equation true. Use drawings or counters if it is helpful.

$$1. \begin{array}{c} \underline{\quad} \\ \text{-----} \\ \underline{\quad} \end{array} + \begin{array}{c} \underline{\quad} \\ \text{-----} \\ \underline{\quad} \end{array} = 18$$

$$2. \begin{array}{c} \underline{\quad} \\ \text{-----} \\ \underline{\quad} \end{array} + \begin{array}{c} \underline{\quad} \\ \text{-----} \\ \underline{\quad} \end{array} = 16$$

Writing Numbers 0-20

ML 6.11



Modeled Review

Name: Avery

Write the missing number.

16 17 18 19 20

I counted 16 and 17,
then counted on to
fill in the blank.



Guided Practice



Write the missing numbers.

1. 3 4 5

2. 6 7 9

3. 2 3 6



Guided Practice



Write the missing numbers.

4.

| | | | |
|----|----|-------------------|-------------------|
| 17 | 18 | <hr/> <hr/> <hr/> | <hr/> <hr/> <hr/> |
|----|----|-------------------|-------------------|

5.

| | | | | |
|----|----|-------------------|----|-------------------|
| 14 | 15 | <hr/> <hr/> <hr/> | 17 | <hr/> <hr/> <hr/> |
|----|----|-------------------|----|-------------------|

6.

| | | | | |
|-------------------|----|----|-------------------|----|
| <hr/> <hr/> <hr/> | 13 | 14 | <hr/> <hr/> <hr/> | 16 |
|-------------------|----|----|-------------------|----|

7.

| | | | | |
|-------------------|-------------------|----|----|-------------------|
| <hr/> <hr/> <hr/> | <hr/> <hr/> <hr/> | 15 | 16 | <hr/> <hr/> <hr/> |
|-------------------|-------------------|----|----|-------------------|



Check



Write the missing numbers.

1.

| | | | | |
|----|-------------------|----|-------------------|----|
| 16 | <hr/> <hr/> <hr/> | 18 | <hr/> <hr/> <hr/> | 20 |
|----|-------------------|----|-------------------|----|

2.

| | | | | |
|-------------------|----|-------------------|-------------------|----|
| <hr/> <hr/> <hr/> | 12 | <hr/> <hr/> <hr/> | <hr/> <hr/> <hr/> | 15 |
|-------------------|----|-------------------|-------------------|----|

Unit 7

Mini-Lessons

Matching Solid Shapes to Real-World Objects

ML 7.02



Modeled Review



Name: Priya

Circle the real-world object that matches the solid shape.

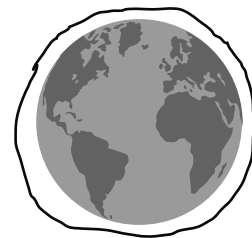
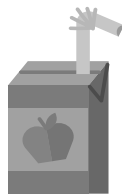
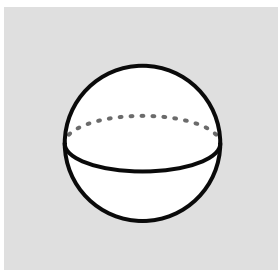

Guided Practice



1. Draw a line from the solid shape to the real-world object that is the same shape.

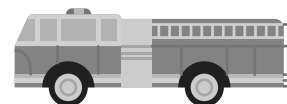
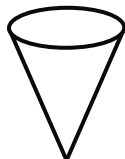
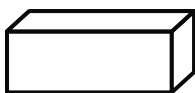









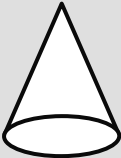
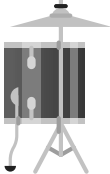
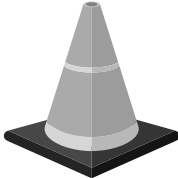
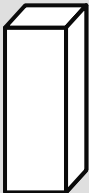



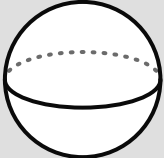

Guided Practice

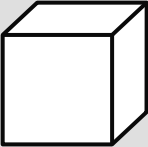

2. Circle the real-world object that matches the solid shape.

| Solid shape | Real-world objects | | |
|---|---|--|---|
|  |  |  | |
|  |  |  |  |
|  |  |  |  |
|  |  |  |  |



Check



Circle the real-world object that matches the solid shape.

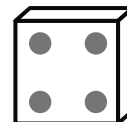
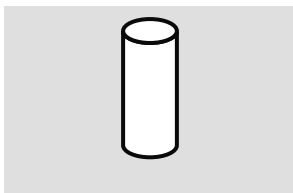

Comparing Objects Using *Heavier* and *Lighter*

ML 7.03



Modeled Review



Name: Tristan

1. Circle the object that is *heavier*.

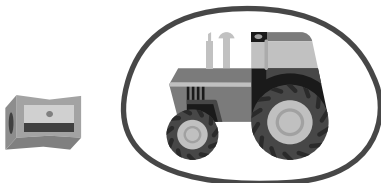

I can't lift a tractor so I know the tractor is *heavier*!

2. Circle the object that is *lighter*.



I've held books and a tissue box and the tissue box was *lighter*!



Guided Practice



1. Draw lines to match the word with the circled image that represents it.

lighter

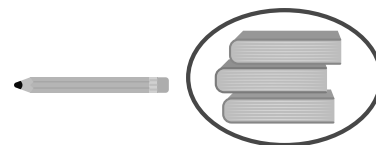

heavier





Guided Practice



2. Circle the object that is *heavier*.

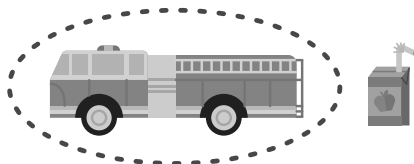

3. Circle the object that is *lighter*.

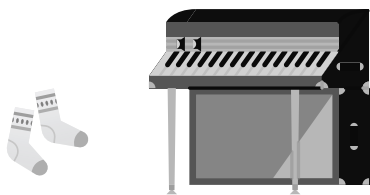

4. Circle the object that is *heavier*.



Check



1. Circle the object that is *lighter*.

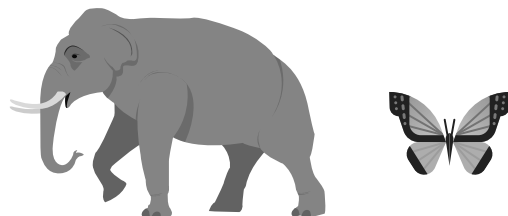

2. Circle the object that is *heavier*.

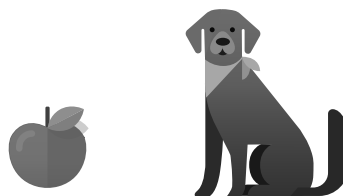

Comparing Objects Using *More* and *Less*

ML 7.04



Modeled Review



Name: Clare

1. Circle the container that holds *more*.

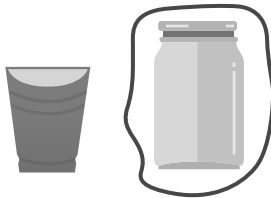

The jar is larger than the cup so I know the jar holds *more*.

2. Circle the container that holds *less*.

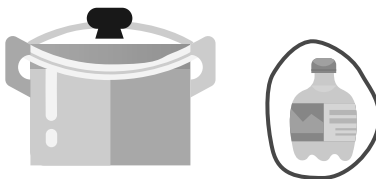

The bottle is smaller than the pot so I know the bottle holds *less*.



Guided Practice



1. Draw lines to match the word with the circled image that represents it.

holds *more*

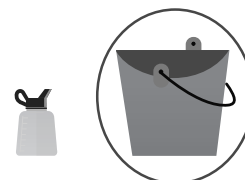

holds *less*

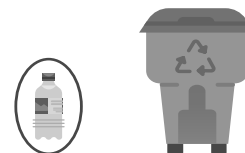



Guided Practice



2. Circle the object that holds *less*.

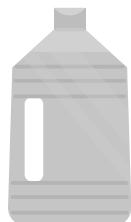

3. Circle the object that holds *more*.



4. Circle the object that holds *less*.



Check



1. Circle the object that holds *less*.



2. Circle the object that holds *more*.

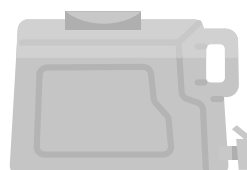

Exploring How Solid Shapes Are Alike or Different

ML 7.05



Modeled Review



Name: Dylan

Circle the group the solid shape belongs in.
Explain your thinking.

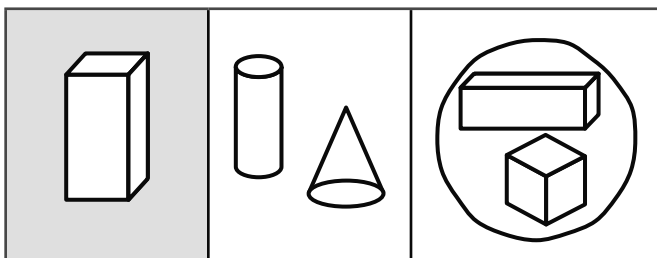

These shapes are alike because they have 6 faces.



Guided Practice



For Problems 1-2, compare the shapes.

1. How are the shapes alike?

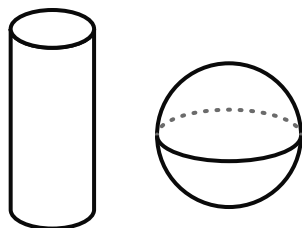

2. How are the shapes different?

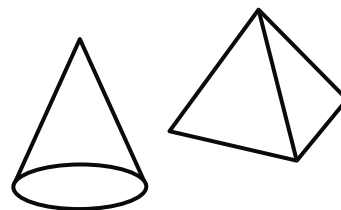



Guided Practice



3. Draw a line to match the *two* shapes that have common attributes.

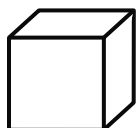
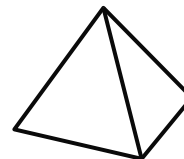
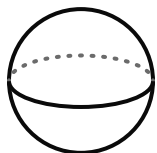

4. Circle the group the shape belongs in. Explain why the shape belongs in that group.

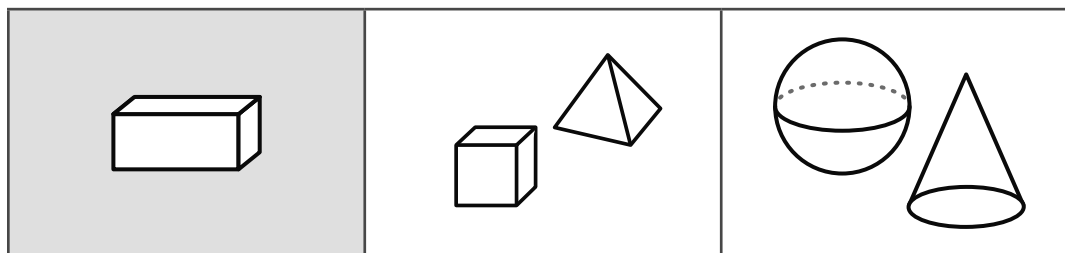

Check



Circle the group the shape belongs in. Explain your thinking.

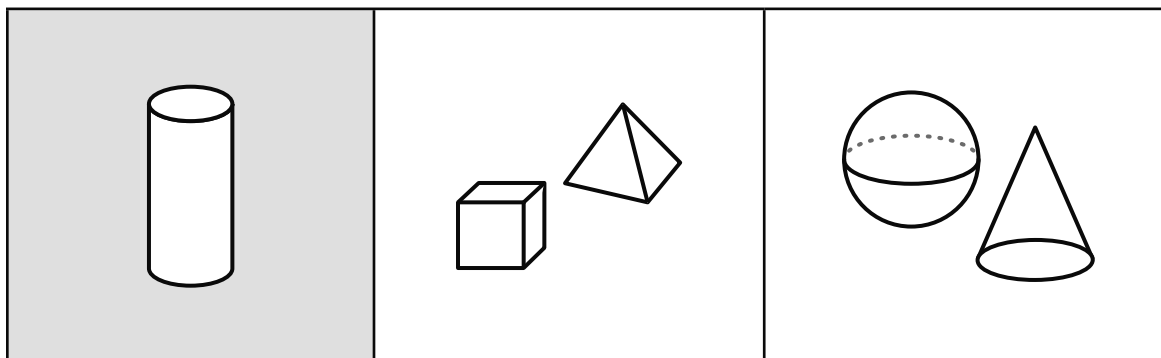

Identifying Solid Shapes

ML 7.06



Modeled Review

Name: Avery

Circle *all* the cylinders.

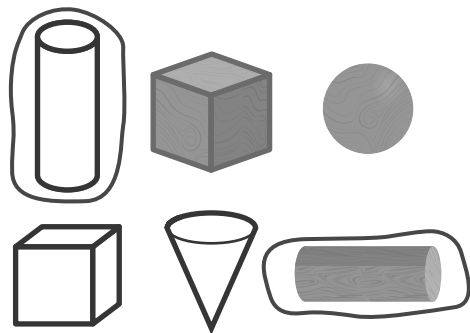

Cylinders
remind me of
markers and cans.



Guided Practice



Use the shapes below to answer Problems 1-4.

1. Point to the cylinder.
2. Point to the cone.
3. Point to the cube.
4. Point to the sphere.

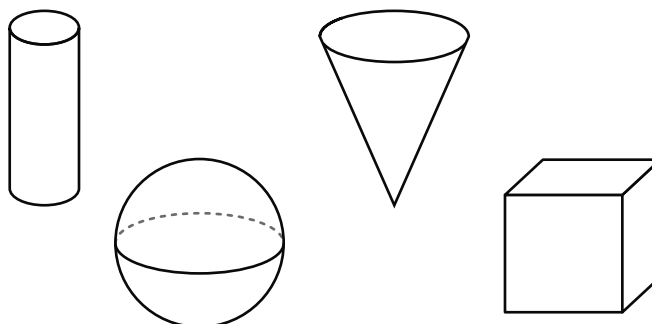



Guided Practice



5. Circle *all* the spheres.

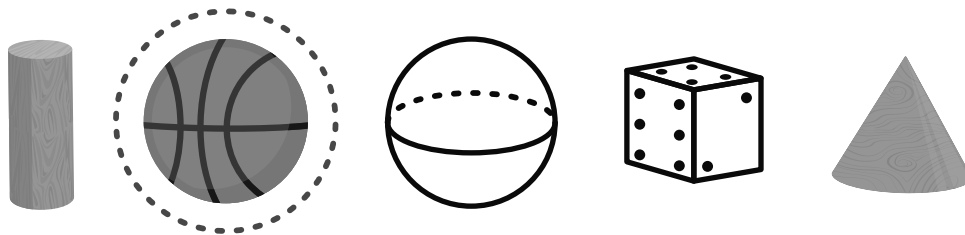

6. Circle *all* the cones.

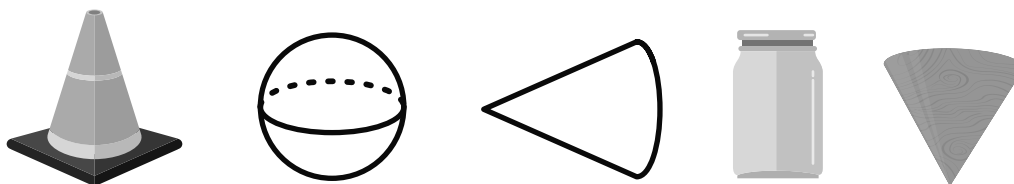

7. Circle *all* the cylinders.

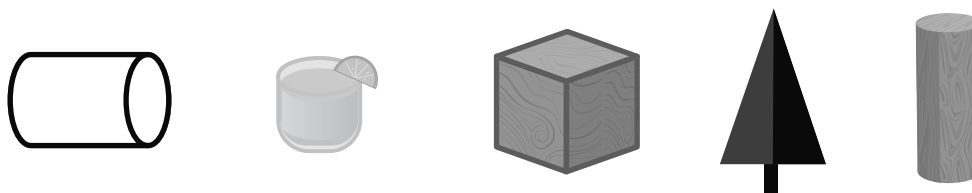

Check



Circle *all* the cubes.

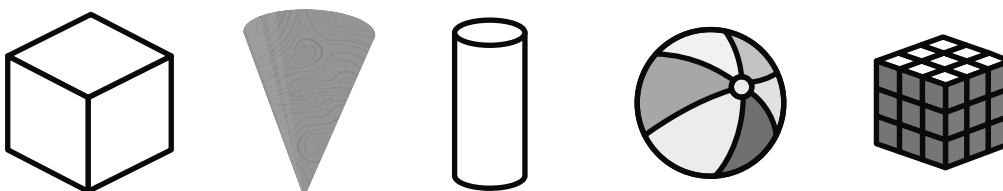

Building Real-World Objects Using Solid Shapes

ML 7.07



Modeled Review



Name: Han

Build the real-world object using solid shapes.

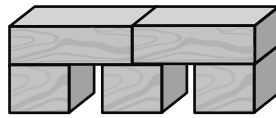

I used solid shapes to build a bridge!



Guided Practice



1. Draw a line from the solid shapes to the matching real-world object.

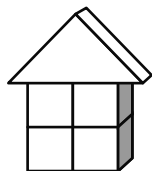
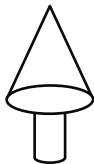
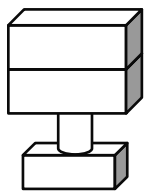



Guided Practice



2. Choose one of the objects and build it using solid shapes. Then describe the shape you built.

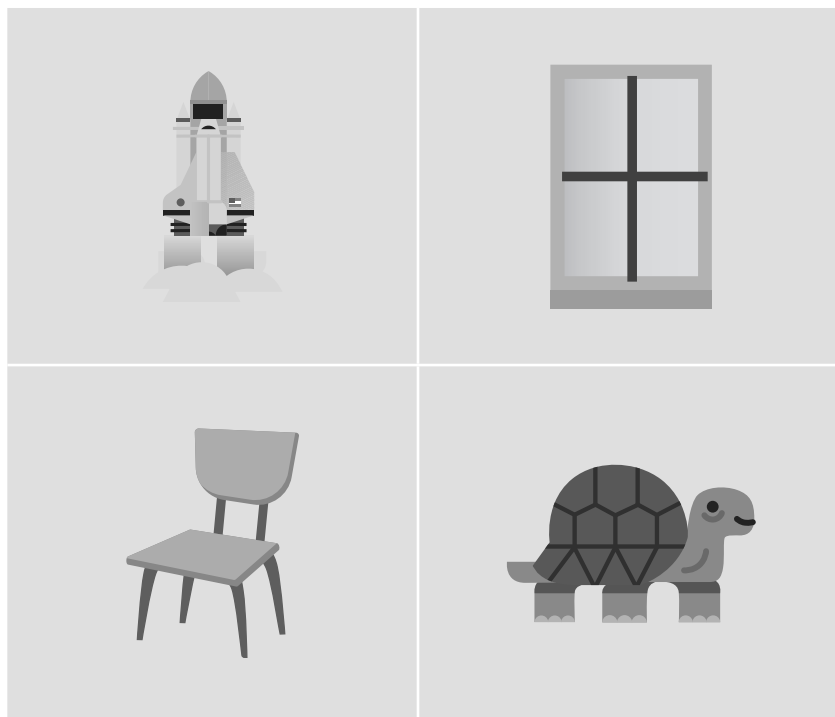

Check



Choose one of the objects and build it using solid shapes. Then describe the shape you built.

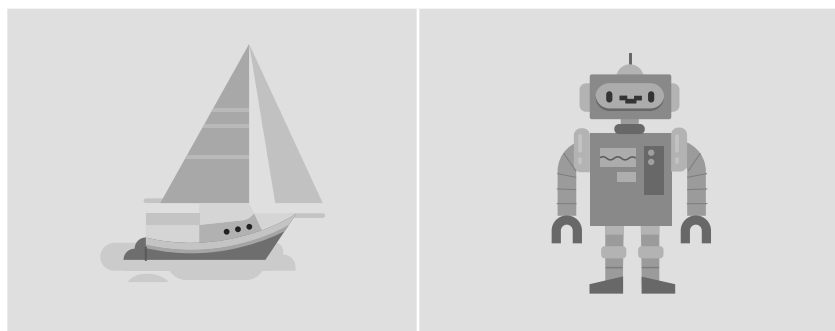

Building Solid Shapes

ML 7.08



Modeled Review



Name: Kai

Build an object using 5 solid shapes. Describe the object you built.

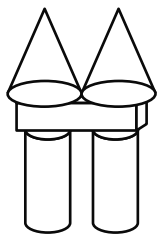

I put the cones above the prism and cylinders to make a castle!



Guided Practice



Where is the prism? Use the word bank if it is helpful.

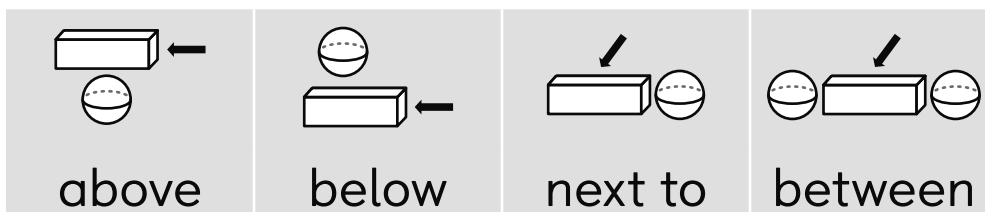

- above below

- between next to

- above between



Guided Practice



Build an object with the given number of shapes. Describe the object you built. Use the word bank if it is helpful.

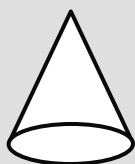

cone

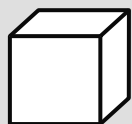

cube

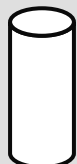

cylinder

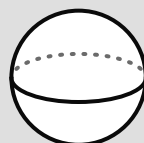

sphere



prism

4. Build an object using 3 shapes.

5. Build an object using 6 shapes.

6. Build an object using 5 shapes.



Check



Build an object using 4 shapes. Describe the object you built. Use the word bank if it is helpful.

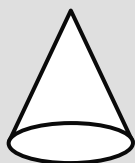

cone

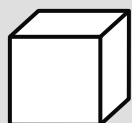

cube



cylinder

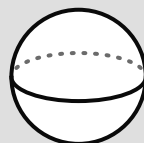

sphere



prism

Making Numbers Within 5

ML 7.09



Modeled Review

Name: Eva

Fill in the expressions to make 4.

1. $3 + \underline{\quad 1 \quad}$

2. $2 + \underline{\quad 2 \quad}$

3. $5 - \underline{\quad 1 \quad}$



Guided Practice



1. Circle *all* of the expressions that have the same value as the given number.

| Number | Expressions | | |
|--------|--|---|---|
| 2 | $3 - 1$ <input type="checkbox"/> <input type="checkbox"/> <input checked="" type="checkbox"/> | $1 + 1$ <input checked="" type="checkbox"/> <input type="checkbox"/> | $4 - 3$ <input type="checkbox"/> <input checked="" type="checkbox"/> <input checked="" type="checkbox"/> <input checked="" type="checkbox"/> |
| 5 | $3 + 2$ <input checked="" type="checkbox"/> <input checked="" type="checkbox"/> <input checked="" type="checkbox"/> <input type="checkbox"/> <input type="checkbox"/> | $4 - 1$ <input type="checkbox"/> <input type="checkbox"/> <input type="checkbox"/> <input checked="" type="checkbox"/> | $4 + 1$ <input checked="" type="checkbox"/> <input checked="" type="checkbox"/> <input checked="" type="checkbox"/> <input checked="" type="checkbox"/> <input type="checkbox"/> |



Guided Practice



2. Fill in the expressions to make 5.

$4 + \underline{\hspace{1cm}}$

$3 + \underline{\hspace{1cm}}$

$2 + \underline{\hspace{1cm}}$

$1 + \underline{\hspace{1cm}}$

3. Fill in the expressions to make 3.

$2 + \underline{\hspace{1cm}}$

$1 + \underline{\hspace{1cm}}$

$4 - \underline{\hspace{1cm}}$

$5 - \underline{\hspace{1cm}}$



Check



Fill in the expressions to make 4.

$3 + \underline{\hspace{1cm}}$

$2 + \underline{\hspace{1cm}}$

$1 + \underline{\hspace{1cm}}$

$5 - \underline{\hspace{1cm}}$

Counting Solid Shapes

ML 7.10



Modeled Review



Name: Santiago

Count the shapes. Write the number to tell how many.



Guided Practice



Count the shapes. Write the number to tell how many.

1.

2.



Guided Practice



Count the shapes. Write the number that tells how many.

3.

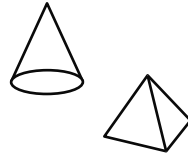
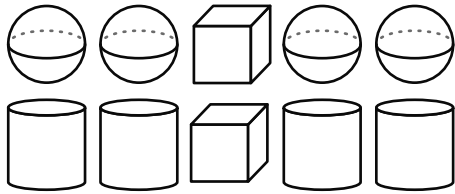

4.

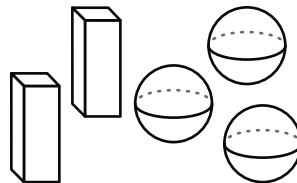
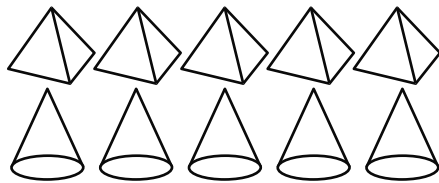

5.

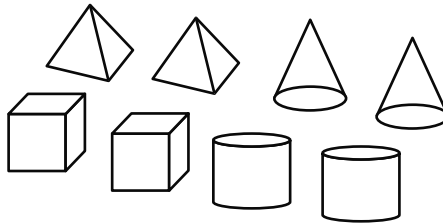
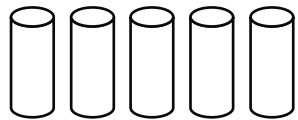
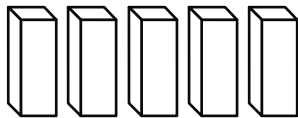



Check



Count the shapes. Write the number that tells how many.

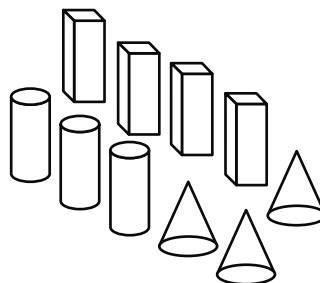
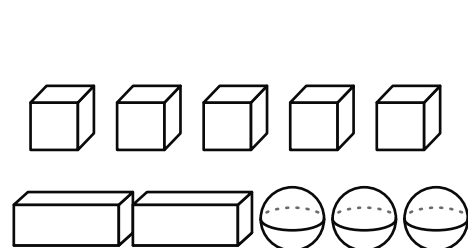

Comparing Groups of Shapes

ML 7.11



Modeled Review



Name: Jada

Write a number to show how many of each shape are in the puzzle. Circle the shape that is used *more*.

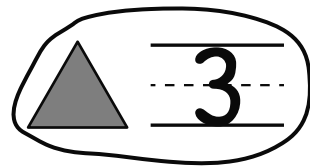
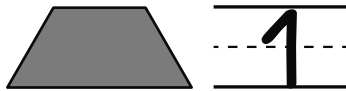
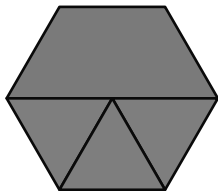

Guided Practice



Compare the shapes using *more*, *fewer*, or the *same*.

1.

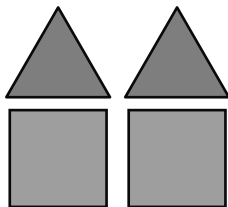

2.

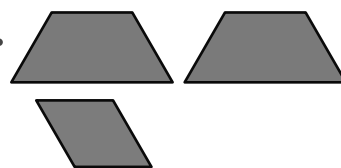

3.

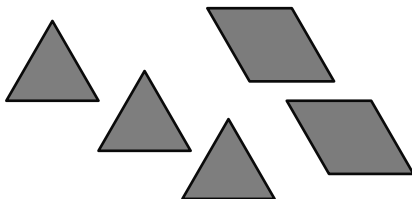

4.

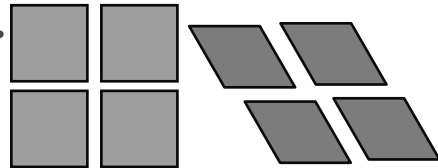



Guided Practice



Write a number to show how many of each shape are in the puzzle.

5. Circle the shape that is used *fewer* times.

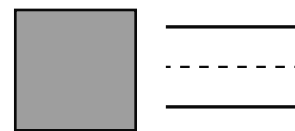
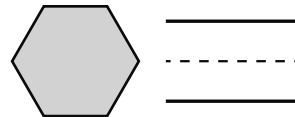
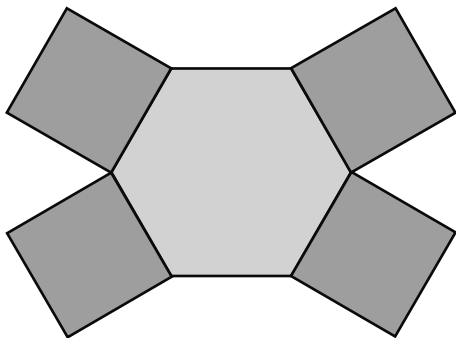

6. Circle the shape that is used *more* times.

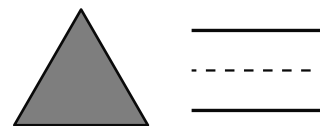
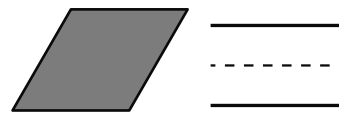
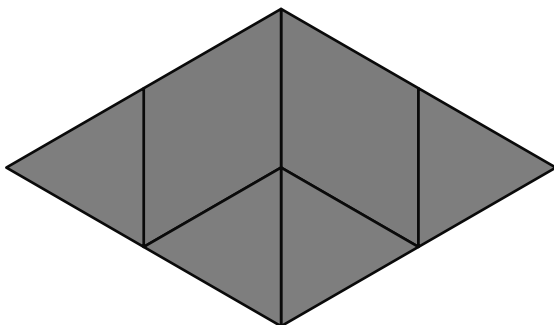

Check



Write a number to show how many of each shape are in the puzzle. Then circle the shape that is used *fewer* times.

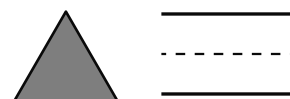
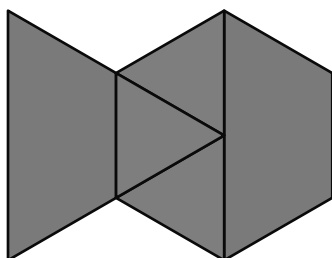

Making 10 in Different Ways

ML 7.12



Modeled Review



Name: Jack

Complete the expressions to make 10. Use the 10-frame if it is helpful.

1. $5 + \underline{\quad 5 \quad}$

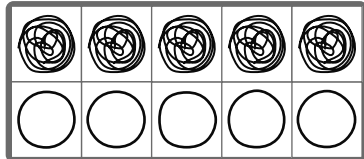

2. $6 + \underline{\quad 4 \quad}$

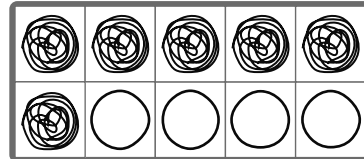

Guided Practice



Complete the expressions to make 10.

1. $3 + \underline{\quad \quad}$

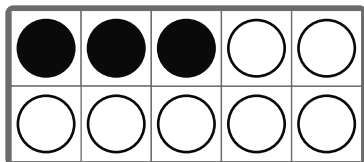

2. $8 + \underline{\quad \quad}$

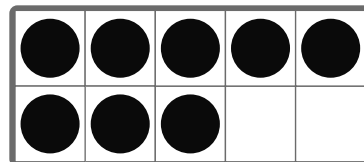

3. $1 + \underline{\quad \quad}$

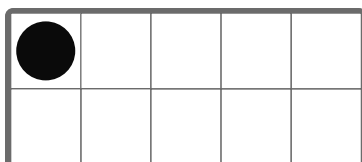

4. $9 + \underline{\quad \quad}$

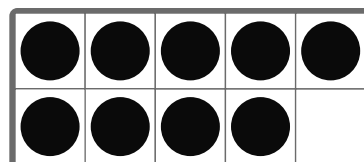



Guided Practice



Fill in the expressions to make 10. Use the 10-frame if it is helpful.

5. $5 + \underline{\quad}$

| | | | | |
|--|--|--|--|--|
| | | | | |
| | | | | |

6. $7 + \underline{\quad}$

| | | | | |
|--|--|--|--|--|
| | | | | |
| | | | | |

7. $2 + \underline{\quad}$

| | | | | |
|--|--|--|--|--|
| | | | | |
| | | | | |

8. $4 + \underline{\quad}$

| | | | | |
|--|--|--|--|--|
| | | | | |
| | | | | |



Check



Fill in the expressions to make 10. Use the 10-frame if it is helpful.

1. $9 + \underline{\quad}$

| | | | | |
|--|--|--|--|--|
| | | | | |
| | | | | |

2. $8 + \underline{\quad}$

| | | | | |
|--|--|--|--|--|
| | | | | |
| | | | | |

Matching Equations to Shapes

ML 7.13



Modeled Review

Name: Maya

Circle the equation that matches the image.

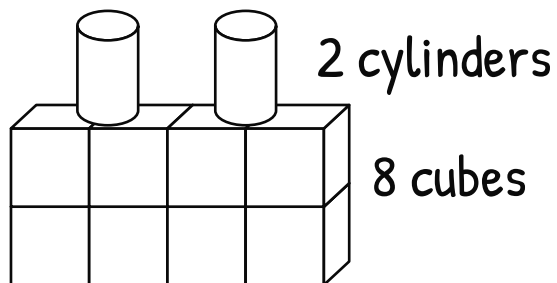

8 and 2 is 10
altogether!

$2 + 6 = 8$

$2 + 8 = 10$

$9 = 4 + 5$



Guided Practice



Circle the equation that matches the image.

1.

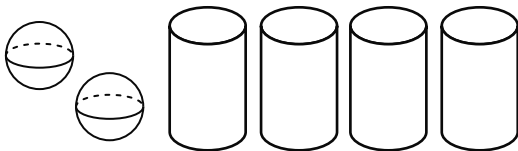

$3 + 5 = 8$

$2 + 4 = 6$

2.

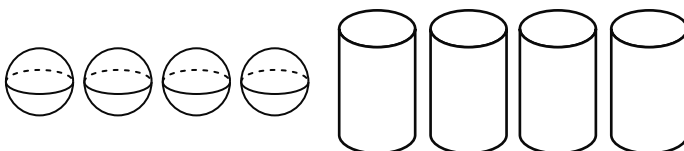

$8 = 4 + 4$

$5 + 4 = 9$



Guided Practice



Circle the equation that matches the image.

3.

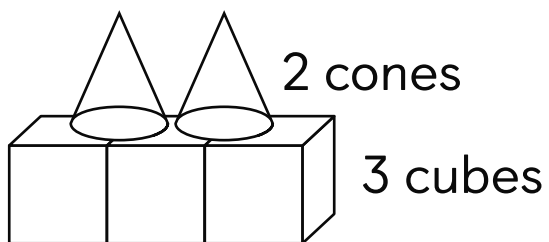

$5 = 2 + 3$

$4 + 3 = 7$

$6 = 3 + 3$

4.

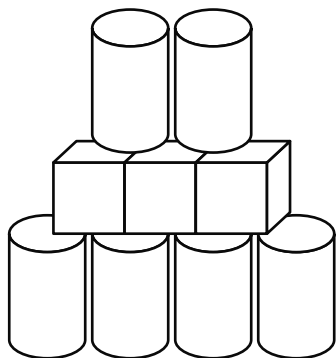

$5 + 4 = 9$

$6 + 3 = 9$

$10 = 6 + 4$



Check



Circle the equation that matches the image.

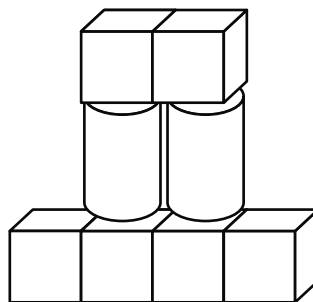

$8 = 3 + 5$

$8 = 6 + 2$

$2 + 5 = 7$

Solving Problems and Selecting Matching Equations

ML 7.14



Modeled Review

Name: Dylan

Solve the story problem. Show your thinking using a drawing. Circle the equation that matches the story.

Santiago used 6 squares and 3 triangles in his picture. How many blocks did he use?



$6 + 2 = 8$

$6 - 3 = 9$

$6 + 3 = 9$



Guided Practice



Solve the story problem. Circle the equation that matches the story.

1. Maya had 9 pattern blocks. She gave 5 to Priya. How many blocks does she have left?

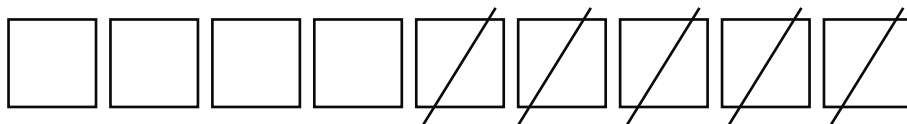

$5 = 9 - 4$

$9 - 5 = 4$

$5 + 4 = 9$



Guided Practice



Solve the story problem. Show your thinking using a drawing. Circle the equation that matches the story.

2. Tristan had 4 shapes. Diego gave him 4 more. How many shapes does Tristan have now?

$$8 = 4 + 4 \quad 0 = 4 - 4 \quad 4 + 5 = 9$$

3. Avery had 7 pattern blocks. She gave away 4. How many blocks does Avery have left?

$$7 - 3 = 7 \quad 7 + 3 = 10 \quad 7 - 4 = 3$$



Check



Solve the story problem. Show your thinking using a drawing. Circle the equation that matches the story.

Clare had 8 shapes. She gave away 2. How many shapes does Clare have left?

$$10 = 8 + 2 \quad 6 = 8 - 2 \quad 8 - 6 = 2$$

Solving Subtraction Problems

ML 7.15



Modeled Review

Name: Jack

Solve the problem. Write an equation to show your thinking.

Diego's bridge is 7 cubes long. He took off 2 cubes. How many cubes are left in Diego's bridge?



$$\underline{7} - \underline{2} = \underline{5}$$



Guided Practice



Solve the problem. Write an equation to show your thinking.

1. Clare had 8 cones. She gave 3 away. How many cones does Clare have left?

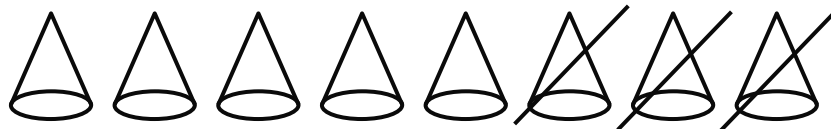

$$8 - \underline{\quad} = \underline{\quad}$$



Guided Practice



Solve the problem. Write an equation to show your thinking.

2. Han built a train with 6 cubes. He took off 2. How many cubes are left in Han's train?



$$\begin{array}{r} \underline{\quad} \\ \text{-----} \\ \underline{\quad} \end{array} - \begin{array}{r} \underline{\quad} \\ \text{-----} \\ \underline{\quad} \end{array} = \begin{array}{r} \underline{\quad} \\ \text{-----} \\ \underline{\quad} \end{array}$$

3. Avery used 9 solid shapes for her castle. 7 shapes fell. How many shapes are still up in her castle?

$$\begin{array}{r} \underline{\quad} \\ \text{-----} \\ \underline{\quad} \end{array} - \begin{array}{r} \underline{\quad} \\ \text{-----} \\ \underline{\quad} \end{array} = \begin{array}{r} \underline{\quad} \\ \text{-----} \\ \underline{\quad} \end{array}$$



Check



Solve the problem. Write an equation to show your thinking.

- Maya had 10 prisms. She gave 3 away to Eva. How many prisms does Maya have left?

$$\begin{array}{r} \underline{\quad} \\ \text{-----} \\ \underline{\quad} \end{array} - \begin{array}{r} \underline{\quad} \\ \text{-----} \\ \underline{\quad} \end{array} = \begin{array}{r} \underline{\quad} \\ \text{-----} \\ \underline{\quad} \end{array}$$

Solving Story Problems and Writing Equations to Match

ML 7.16



Modeled Review

Name: Tristan

Solve the problem. Fill in the equation to show your thinking.

Jada had 5 pattern blocks and then used 3 more. How many pattern blocks does she have now?

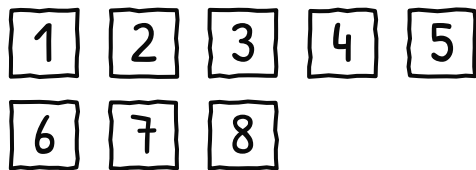

$$\underline{5} + \underline{3} = \underline{8}$$



Guided Practice



Solve the problem. Fill in the equation to show your thinking.

- Eva used 5 cubes and 2 cylinders to build a tower. How many solid shapes did she use?

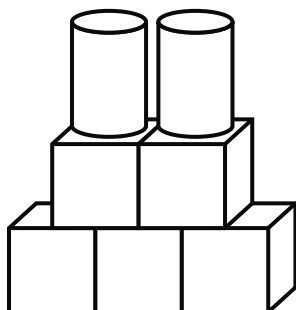

$$\underline{\quad} + \underline{\quad} = \underline{\quad}$$



Guided Practice



Solve the problem. Fill in the equation to show your thinking.

2. Avery had 7 cubes. She gave 4 away. How many cubes does Avery have left?

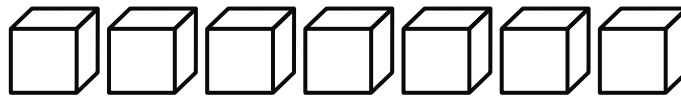

$$\begin{array}{r} \underline{\quad} \\ \text{-----} \\ \underline{\quad} \end{array} - \begin{array}{r} \underline{\quad} \\ \text{-----} \\ \underline{\quad} \end{array} = \begin{array}{r} \underline{\quad} \\ \text{-----} \\ \underline{\quad} \end{array}$$

3. Han used 6 cones. Then he used 3 prisms. How many shapes did Han use altogether?

$$\begin{array}{r} \underline{\quad} \\ \text{-----} \\ \underline{\quad} \end{array} + \begin{array}{r} \underline{\quad} \\ \text{-----} \\ \underline{\quad} \end{array} = \begin{array}{r} \underline{\quad} \\ \text{-----} \\ \underline{\quad} \end{array}$$



Check



Solve the problem. Write an equation that represents it.

Jack had 9 cylinders. He gave 4 to Clare. How many shapes does Jack have left?

$$\begin{array}{r} \underline{\quad} \\ \text{-----} \\ \underline{\quad} \end{array} - \begin{array}{r} \underline{\quad} \\ \text{-----} \\ \underline{\quad} \end{array} = \begin{array}{r} \underline{\quad} \\ \text{-----} \\ \underline{\quad} \end{array}$$



Extensions

Name

Date

**You Choose!**

Pick any problem to start with.

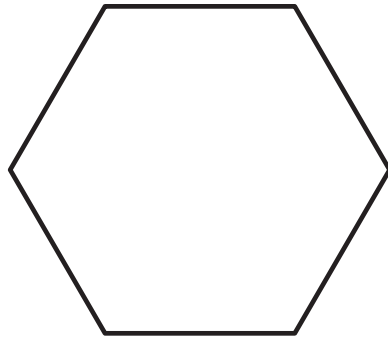
1**You'll need . . .**

pattern blocks

Directions:Use **1** pattern block to make this shape.Use **2** pattern blocks to make this shape.Use **3** pattern blocks to make this shape.Use **4** pattern blocks to make this shape.Use **5** pattern blocks to make this shape.Use **6** pattern blocks to make this shape.

Name Date



You Choose!

Pick any problem to start with.

2

Clare's pictures



Solid shapes

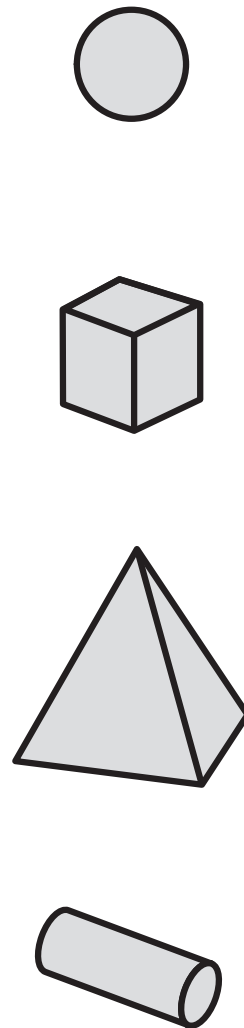

Directions: Clare drew pictures of shapes from different sides. Draw lines to match each picture Clare drew with a solid shape.

Name

Date



You Choose!

Pick any problem to start with.

1

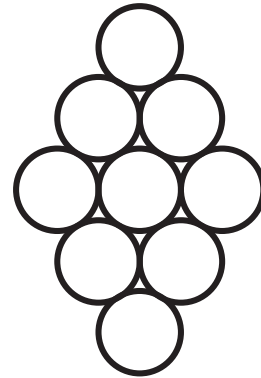
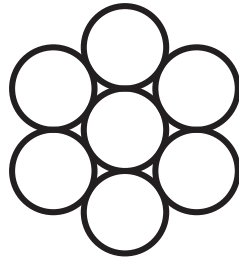

Directions: Color each group of dots using **2** different colors to show how you see them.

Name

Date

2



Show your thinking.



Directions: Figure out if there are enough balls of yarn for each kitten to have 1 ball of yarn.

Figuring Out How Many

Name

Date

Connected
shapes

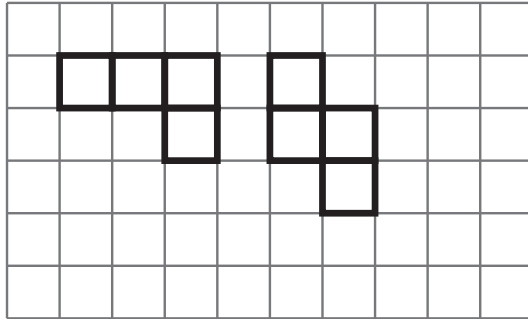

Not connected
shapes

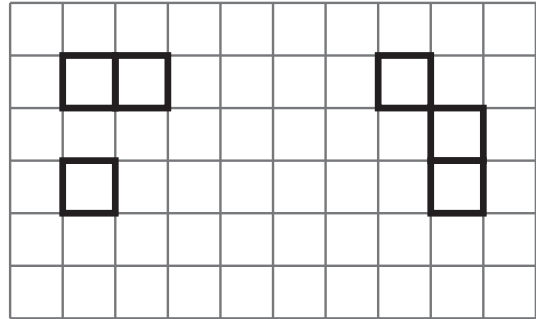

1



Draw

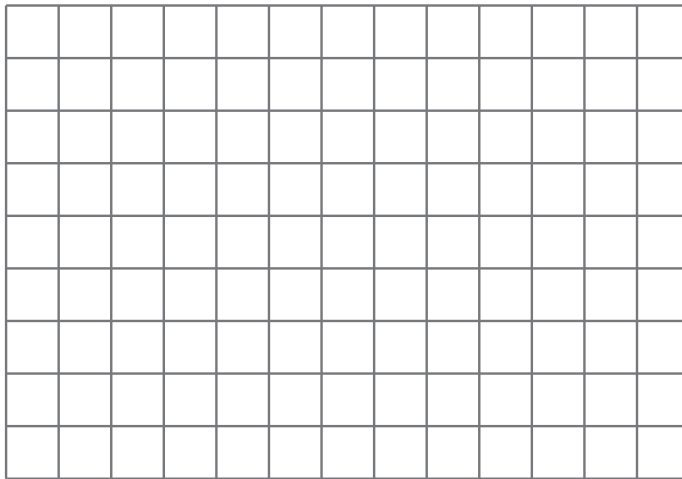

Directions: Draw 1 connected shape with 5 squares.

Name Date

2



Draw

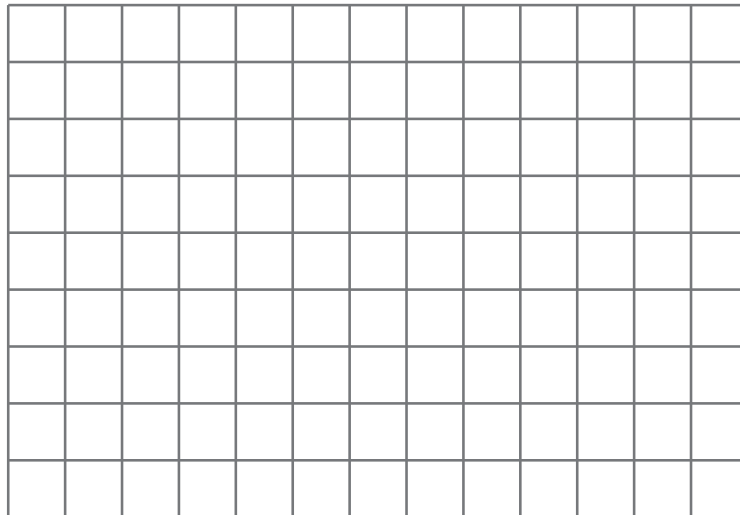

Directions: Draw a different connected shape with 5 squares.

3



Draw

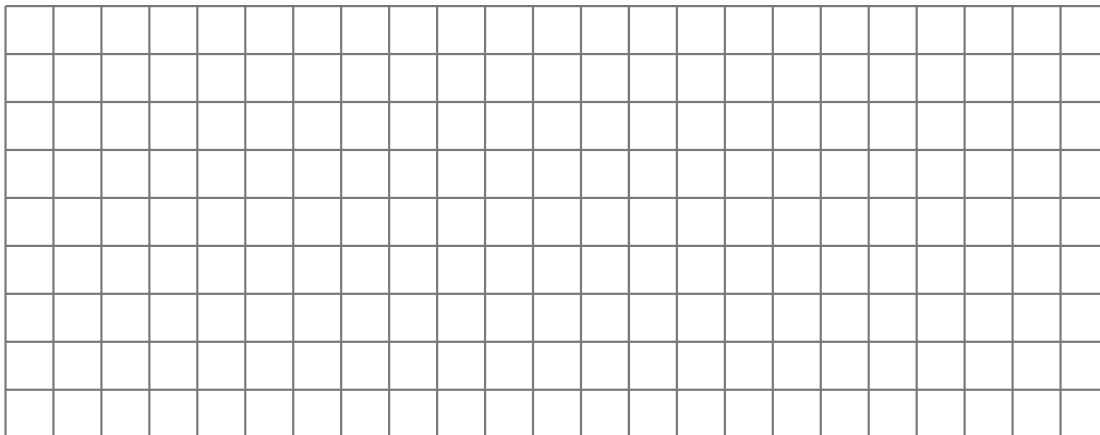

Directions: 12 connected shapes can be made with 5 squares. Draw as many connected shapes as you can.

Counting and Comparing Objects

Name Date

**You Choose!**

Pick any problem to start with.

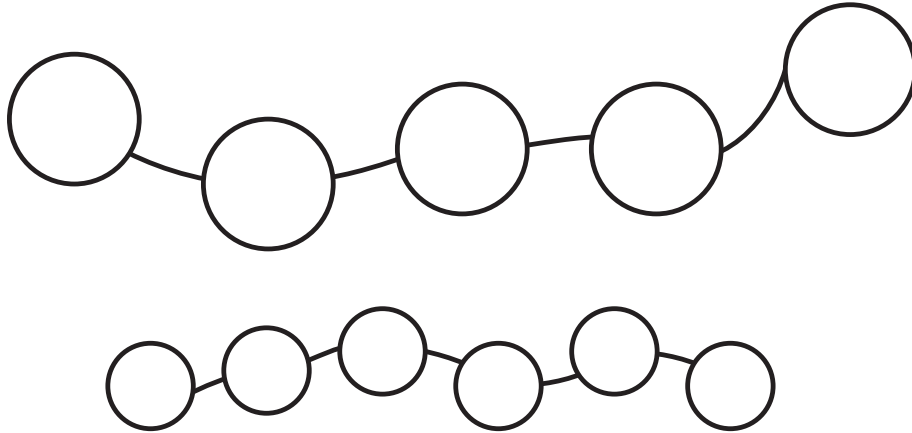
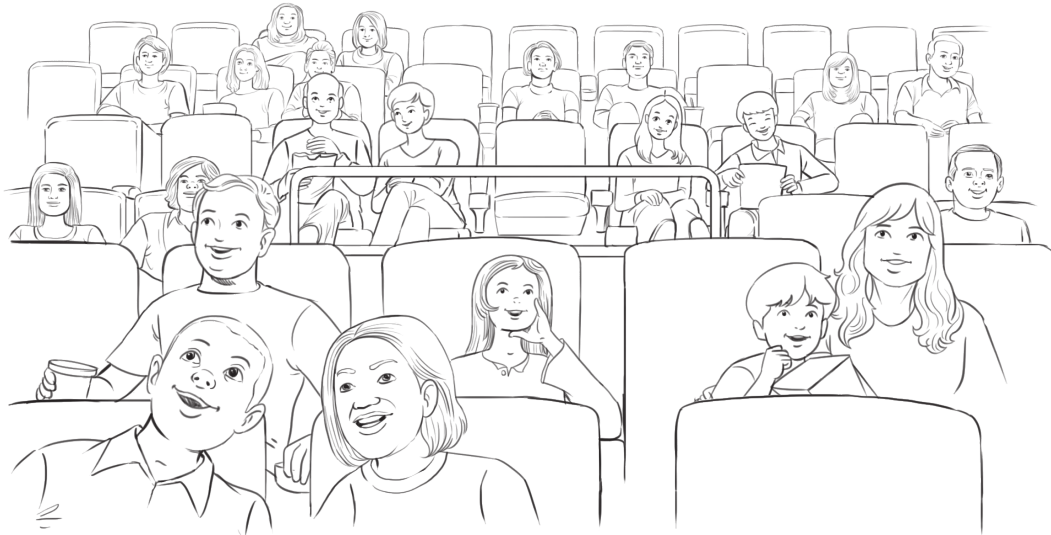
1**Directions:** Color the string that has *more* beads.**2****Directions:** Figure out if there are *more* chairs or people in the picture.

Name Date

Rows

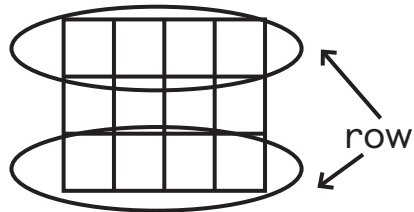

Columns

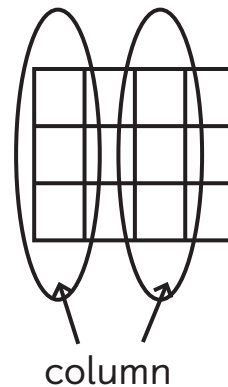

3

| | | |
|---|---|---|
| 2 | 1 | 3 |
| 1 | 3 | — |
| 3 | 2 | 1 |

| | | |
|---|---|---|
| — | 3 | 1 |
| 1 | 2 | — |
| 3 | 1 | 2 |

Directions: Write the numbers 1, 2, and 3 in the empty boxes so that the numbers do not repeat in each row or in each column.

4

| | | |
|---|---|---|
| 1 | 3 | 2 |
| 3 | — | — |
| 2 | — | 3 |

| | | |
|---|---|---|
| 1 | — | — |
| — | — | 2 |
| — | 3 | — |

Directions: Write the numbers 1, 2, and 3 in the empty boxes so that the numbers do not repeat in each row or in each column.

Name

Date

**You Choose!**

Pick any problem to start with.

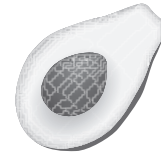
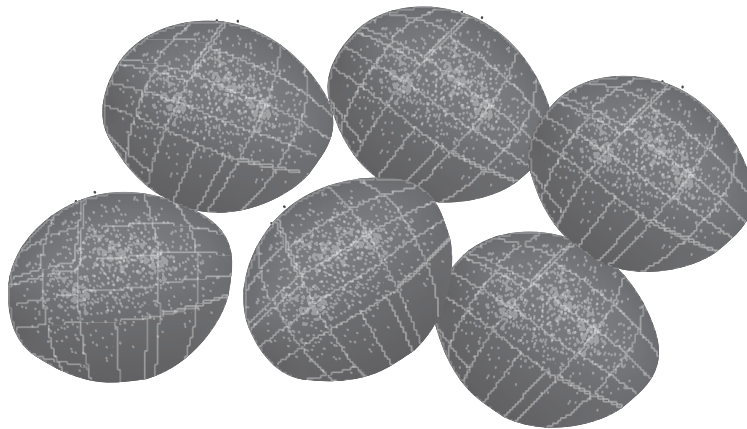
1

avocado

Directions: Jada used some avocados and left the avocado pits. Figure out how many avocados Jada used. Explain how you figured it out.

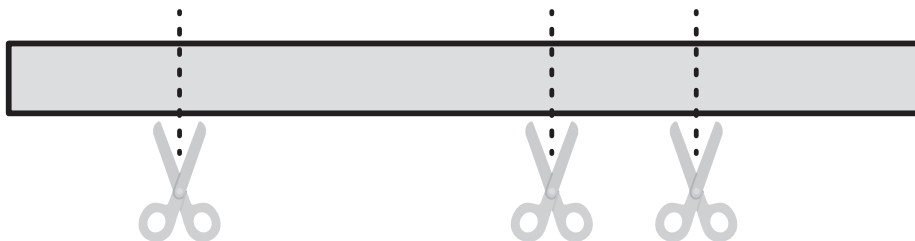
2

Directions: Shawn is going to cut a ribbon in 3 places. Figure out how many pieces of ribbon Shawn will get.

Name Date

3



Show your thinking.



Directions: Priya had a ribbon. She cut the ribbon to get 7 pieces. Figure out how many cuts Priya made to get 7 pieces of ribbon.

Name Date

**You Choose!**

Pick any problem to start with.

1

Show your thinking.

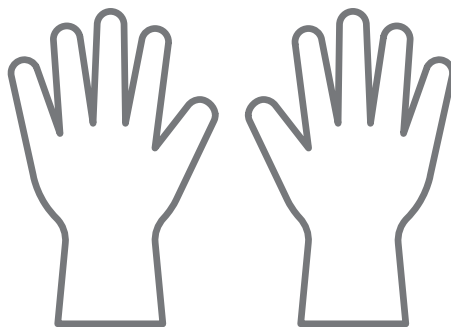
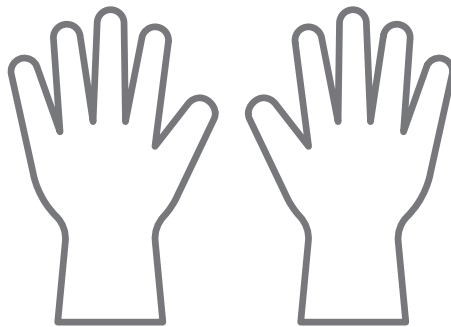
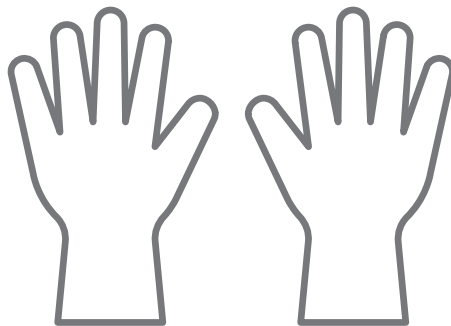

Directions: Circle the fingers to show different ways to make 6. Show as many ways as you can.

Name Date

2

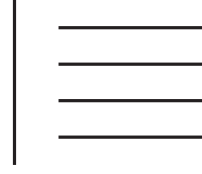
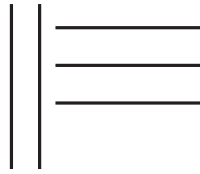
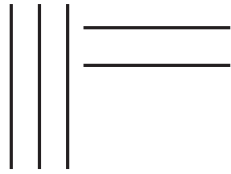

 Draw

Directions: Here is a pattern. Draw the next picture in the pattern.

Name _____ Date _____

**You Choose!**

Pick any problem on this page to start with.

1

1, 2, 3

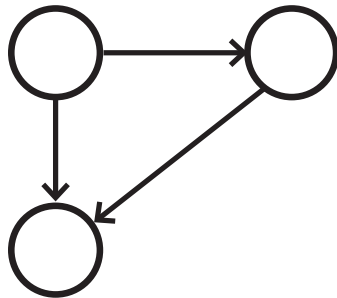

2, 3, 5

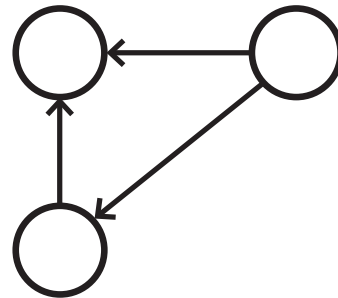

1, 2, 3, 4

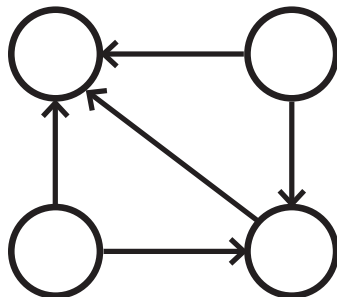

2, 6, 8, 9

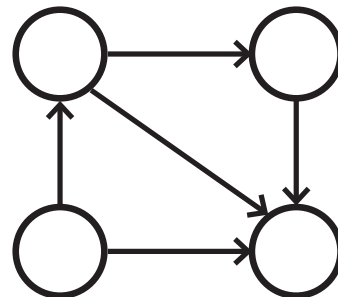

1, 2, 3, 4

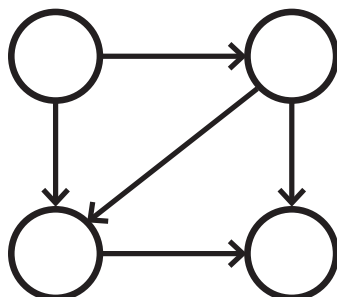

3, 5, 7, 9

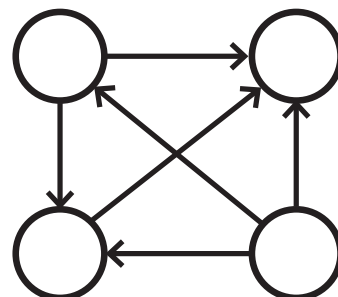

Directions: Write the numbers in the circles so that the arrows point to the smaller numbers.

Name Date.....

2



Show your thinking.

.....

Directions: Priya, Clare, and Shawn compared their heights. Priya was taller than Shawn. Shawn was taller than Clare. Who is the tallest person?

3



Show your thinking.

.....

Directions: Han is older than Diego but younger than Jada. Who is older, Diego or Jada?

Name

Date

**You Choose!**

Pick any problem to start with.

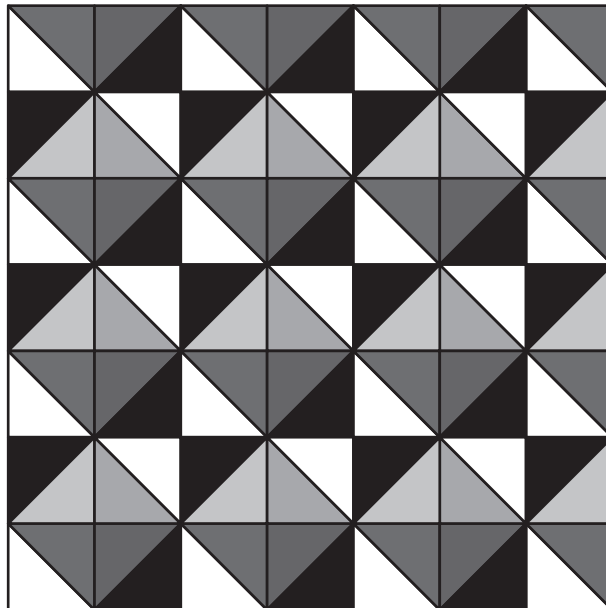
1**Directions:** Where do you see triangles in the picture? Where do you see rectangles in the picture?**2**

Shape A

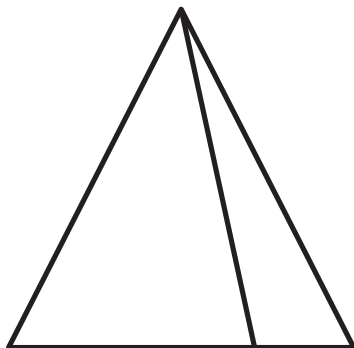

Shape B

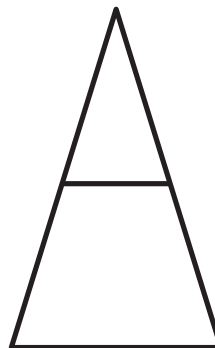

Shape C

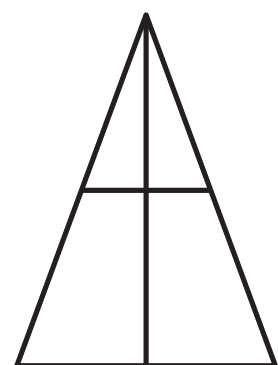
**Directions:** How many triangles do you see in each shape?

Name

Date

3

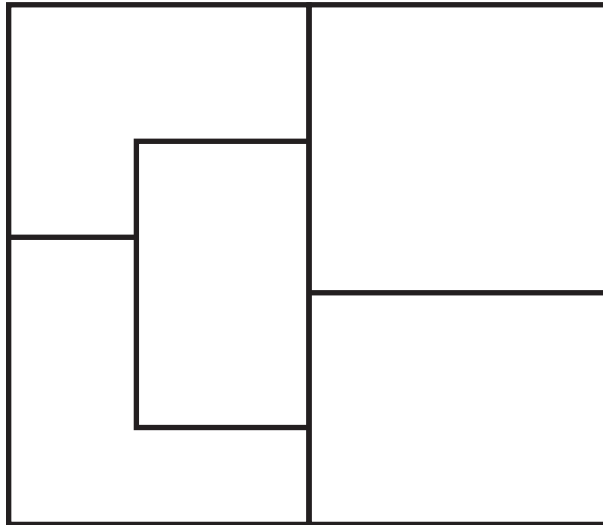

Directions: Diego put some sticky notes on the board. Number the sticky notes in the order Diego put them on the board.

Putting Shapes Together

Name Date

**You Choose!**

Pick any problem to start with.

1

1 toothpick |

1 square **Directions:** Move 1 toothpick to make 1 square.

1 toothpick |

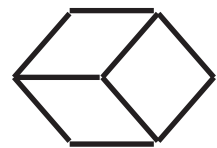
1 triangle **Directions:** Move 2 toothpicks to make 4 triangles.

1 toothpick |

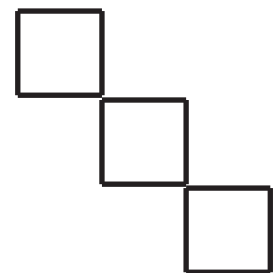
1 square **Directions:** Move 4 toothpicks to make 5 squares.

Name Date

2

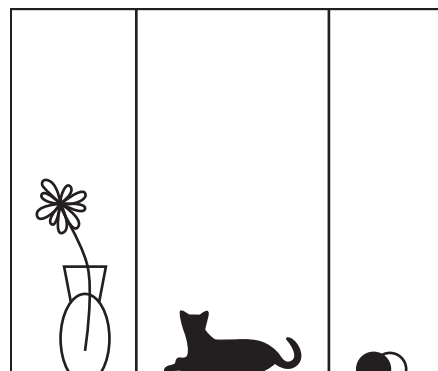
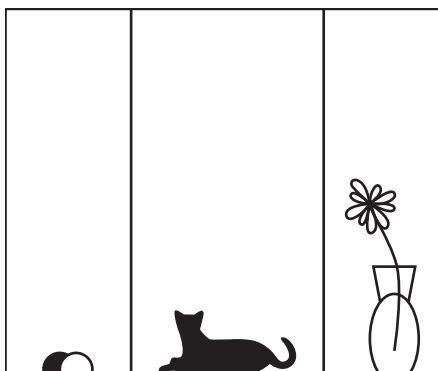
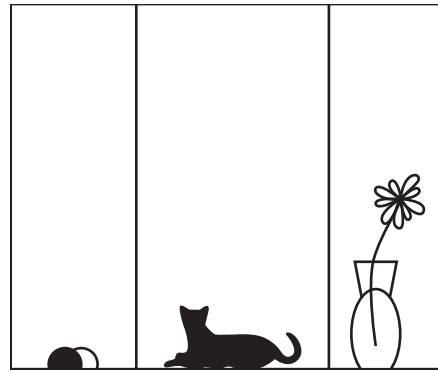
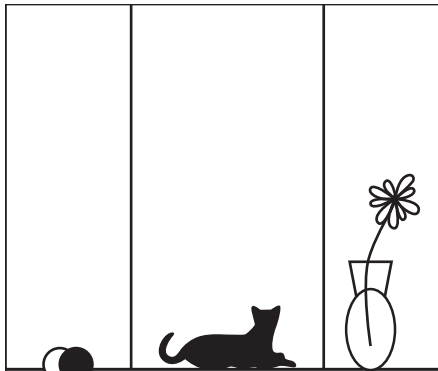
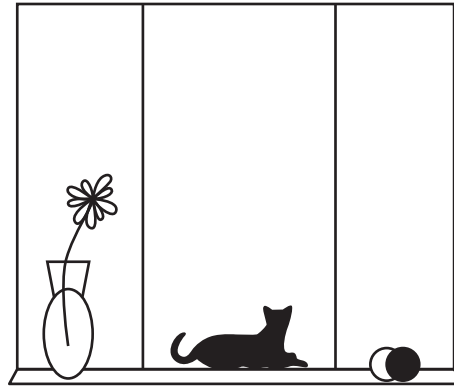

Directions: Clare and Han are standing in front of the same window of a house. Clare is inside the house and Han is outside. This is what Clare sees. Circle the picture that shows what Han sees.

Name Date

3

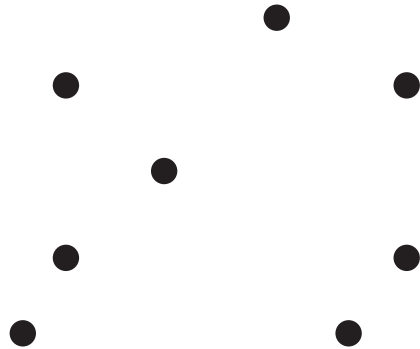

Directions: Connect 4 dots to make a rectangle.

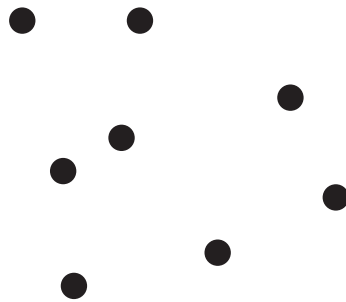

Directions: Connect 4 dots to make a square.

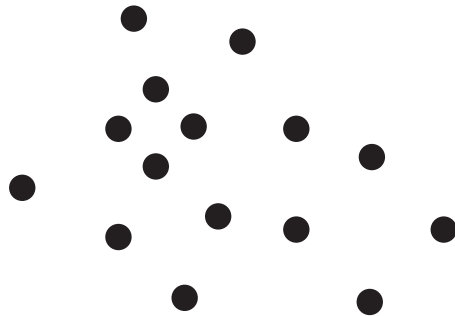

Directions: Connect dots to make 3 squares.

Name _____ Date _____

**You Choose!**

Pick any problem to start with.

1

Show your thinking. _____

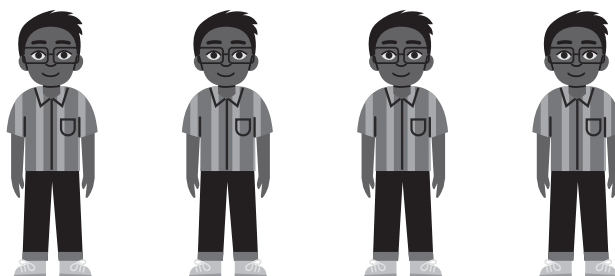

Directions: Four boys are standing in a row. A girl will stand between every 2 boys. How many children will there be in total?

2

Show your thinking. _____



Directions: There are some apricots on a plate. If Elena and Diego each take 3 apricots, 1 will be left over. If Elena and Diego each take 4 apricots, 1 will be missing. How many apricots are on the plate?

Name

Date

3



Draw

A large, empty rounded rectangle with a thin grey border, intended for the student to draw the fruits described in the directions.

Directions: There are some fruits on a plate. All of the fruits are oranges except 2, all are bananas except 2, and all are apples except 2. Draw the fruits that are on the plate.

Name _____ Date _____

**You Choose!**

Pick any problem to start with.

1**Show your thinking.**

Directions: Priya and Shawn had a total of 10 books. Priya gave 1 book to Shawn. How many books do they have together now?

2**Show your thinking.**

lizard



snake



Directions: There were 5 eggs in a terrarium. Lizards and snakes hatched from the eggs. There are now a total of 8 legs. How many lizards and how many snakes hatched from the eggs?

Name

Date

3



Show your thinking.

A large, empty rounded rectangular box for showing work.

Directions: Jada had 7 apples. She gave Clare 3 apples. Now, Jada and Clare have the same number of apples. How many apples did Clare have to start with?

Name

Date

**You Choose!**

Pick any problem to start with.

1

$+ 1 = 8$



$+ = 4$

$7 -$



$= 2$



$= 9$



$- 4 = 4$



$+ 1 = 9$



$=$



$=$



$=$



$=$



$=$



$=$

Directions: There is a number hidden under each animal picture. Figure out what number is under each animal picture.

Name Date

2

1 is I

4 is IV

7 is VII

2 is II

5 is V

8 is VIII

3 is III

6 is VI

9 is IX

$$I + II = \underline{\quad} \quad V + III = \underline{\quad} \quad IX - I = \underline{\quad}$$

Directions: Look at how the Romans wrote numbers. Solve each problem written with Roman numerals.

3

Here is an example.

| | | |
|---|---|---|
| 9 | 2 | 8 |
| 1 | 3 | 7 |
| 1 | 3 | 6 |

$$9 + 1 = 10$$

$$2 + 8 = 10$$

$$3 + 7 = 10$$

$$1 + 3 + 6 = 10$$

| | | |
|---|---|---|
| 1 | 8 | 2 |
| 3 | 6 | 4 |
| 6 | 5 | 5 |

| | | |
|---|---|---|
| 2 | 6 | 2 |
| 3 | 9 | 7 |
| 7 | 1 | 3 |

| | | |
|---|---|---|
| 4 | 6 | 2 |
| 8 | 2 | 4 |
| 1 | 9 | 4 |

Directions: Draw lines to split each grid into parts. The numbers in each part should equal 10.

Name Date



You Choose!

Pick any problem to start with.

1

Here is an example.

| | | |
|---|---|---|
| 1 | 1 | 4 |
| 7 | 8 | 5 |
| 1 | 3 | 6 |

$$1 + 7 + 1 = 9$$

$$1 + 8 = 9$$

$$4 + 5 = 9$$

$$3 + 6 = 9$$

Draw

| | | |
|---|---|---|
| 1 | 8 | 3 |
| 7 | 2 | 4 |
| 2 | 3 | 6 |

| | | | |
|---|---|---|---|
| 1 | 5 | 3 | 2 |
| 8 | 1 | 5 | 3 |
| 4 | 2 | 4 | 3 |
| 1 | 2 | 9 | 1 |

Directions: Draw lines to split each grid into parts. The numbers in each part should add up to 9.

Name Date

2



Show your thinking.

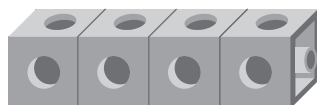

Directions: Show all the ways to break a tower of 4 cubes into 2 parts. Write the number of different ways you find.



Show your thinking.

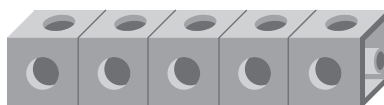

Directions: Show all the ways to break a tower of 5 cubes into 2 parts. Write the number of different ways you find.



Show your thinking.

Directions: Show all the ways to break towers of 6 cubes, 7 cubes, and 8 cubes into 2 parts. For each tower, write the number of different ways you find. What patterns do you notice in the number of ways?

More Types of Story Problems

Name _____ Date _____

**You Choose!**

Pick any problem to start with.

1

Show your thinking. _____



Directions: Clare and Shawn had a total of 6 apples. Clare gave 1 apple to Shawn. How many apples do they have together now?

2

Show your thinking. _____



Directions: Han had 7 pens. He gave Priya 2 pens. Now, Han and Priya have the same number of pens. How many pens did Priya have to start with?

Name

Date

3

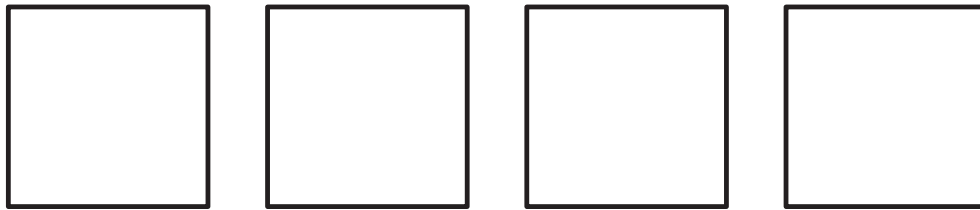

Directions: Here are number cards and 4 empty boxes. Write each number in a box so that the numbers in each box have the same total.

Making and Breaking Apart 10

Name _____ Date _____

**You Choose!**

Pick any problem to start with.

1

Show your thinking. _____

1

2

3

4

5

Directions: Draw an **X** on 2 of the numbers so that the remaining numbers have a value of 10. Find as many ways as possible.

2

Show your thinking. _____

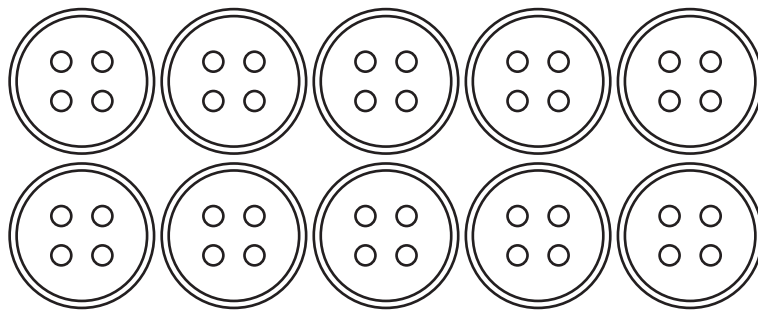

Directions: Diego, Han, Jada, and Priya have 10 buttons together. Each of them has a different number of buttons. Jada has the greatest number of buttons and Priya has the fewest number of buttons. Who has more buttons, Jada and Priya or Diego and Han?

Name

Date

3



Show your thinking.

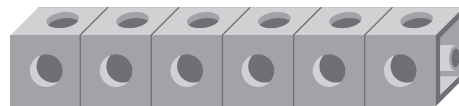

Directions: Show all the ways to break a tower of 6 cubes into **2** parts. Write the number of different ways you find.



Show your thinking.

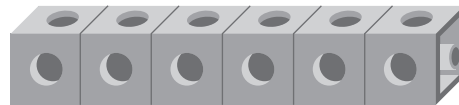

Directions: Show all the ways to break a tower of 6 cubes into **3** parts. Write the number of different ways you find.

Name

Date



Show your thinking.

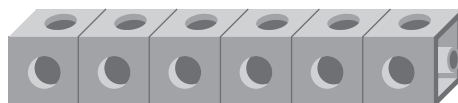

Directions: Show all the ways to break a tower of 6 cubes into **4** parts. Write the number of different ways you find.



Show your thinking.

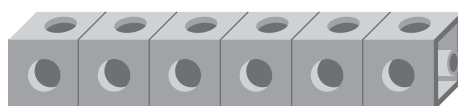

Directions: Show all the ways to break a tower of 6 cubes into **5** parts. Write the number of different ways you find.

Counting Teen Numbers

Name Date

**You Choose!**

Pick any problem to start with.

1

Show your thinking.

Directions: Jada is standing in line at the cafeteria. She is 6th in line if you count from the beginning and 9th in line if you count from the end. How many people are in the line?

Name _____ Date _____

2

1 is ●

5 is 

2 is ●●

7 is 

3 is ●●●

10 is 

4 is ●●●●

 = _____
  = _____
  = _____
  = _____

6 is _____ 11 is _____ 18 is _____ 20 is _____

Directions: Look at how the Mayans wrote numbers. Write the value of each Mayan number. Then write each number using the Mayan system.

Name _____ Date _____

**You Choose!**

Pick any problem to start with.

1

$$17 - \text{turtle} = 14$$

$$\text{whale} + \text{whale} = 18$$

$$\text{elephant} + \text{tiger} = 12$$

$$\text{snake} + \text{bear} + \text{bear} = 14$$

$$\text{elephant} - \text{tiger} = 2$$

$$\text{snake} + \text{snake} + \text{bear} = 10$$

$$\text{turtle} = \underline{\hspace{2cm}}$$

$$\text{whale} = \underline{\hspace{2cm}}$$

$$\text{elephant} = \underline{\hspace{2cm}}$$

$$\text{snake} = \underline{\hspace{2cm}}$$

$$\text{tiger} = \underline{\hspace{2cm}}$$

$$\text{bear} = \underline{\hspace{2cm}}$$

Directions: There is a number hidden under each animal picture. Figure out what number is under each animal picture.

Name Date

2

Here is an example with numbers from 1 to 12.

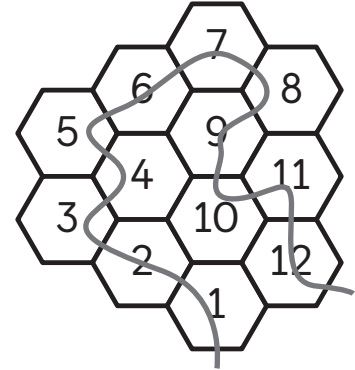

Use numbers from 11 to 20.

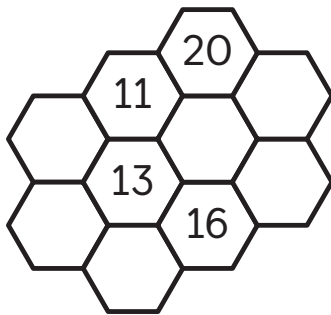

Use numbers from 4 to 17.

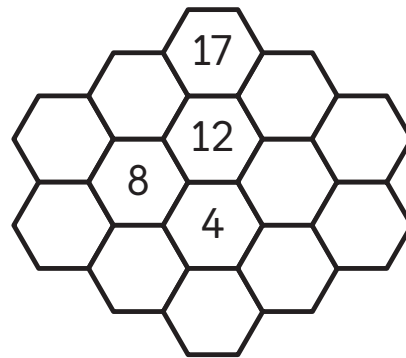

Use numbers from 10 to 20.

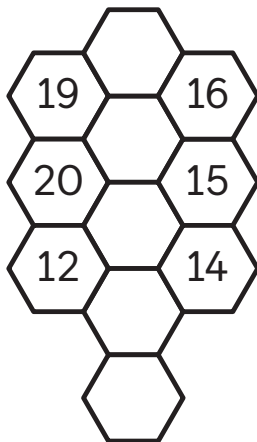

Use numbers from 5 to 15.

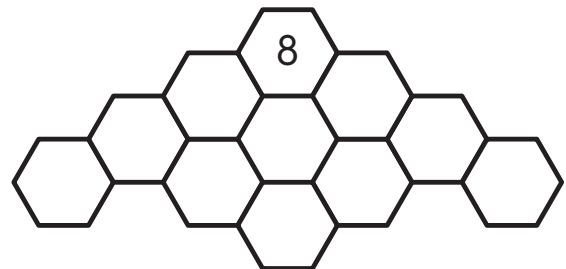

Directions: Fill in each empty tile with a number so that a path of numbers can be traced in order.

Name _____ Date _____

3

$$\boxed{A} + \boxed{B} + \boxed{B} = \boxed{B} \boxed{B}$$

$$\boxed{N} + \boxed{N} + \boxed{N} = \boxed{T} \boxed{N}$$

$$\boxed{X} + \boxed{y} + \boxed{y} = \boxed{X} \boxed{y}$$

$$\boxed{A} = \underline{\hspace{2cm}}$$

$$\boxed{B} = \underline{\hspace{2cm}}$$

$$\boxed{N} = \underline{\hspace{2cm}}$$

$$\boxed{T} = \underline{\hspace{2cm}}$$

$$\boxed{X} = \underline{\hspace{2cm}}$$

$$\boxed{y} = \underline{\hspace{2cm}}$$

Directions: There is a number hidden under each letter card. Figure out what number is under each letter card.

Exploring Solid Shapes

Name

Date



You Choose!

Pick any problem to start with.

1

Shape

Missing part

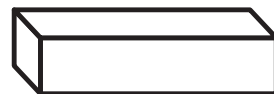
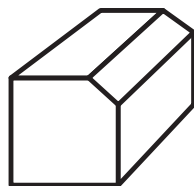
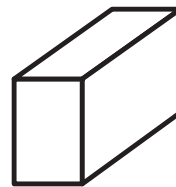
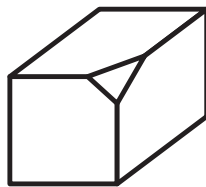
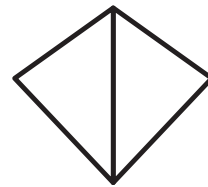
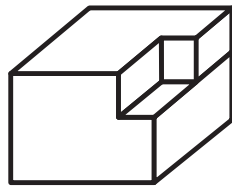
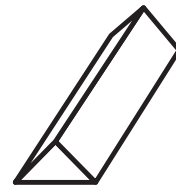
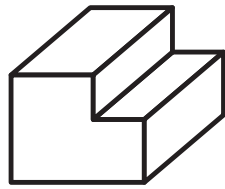

Directions: Here are parts of different objects. Draw lines to match the shapes with their missing part to make a solid shape.

Name Date

2

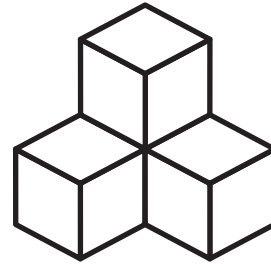
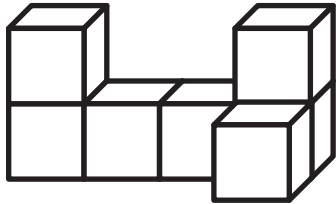

Directions: How many cubes do you need to build each shape?

Name Date

**You Choose!**

Pick any problem to start with.

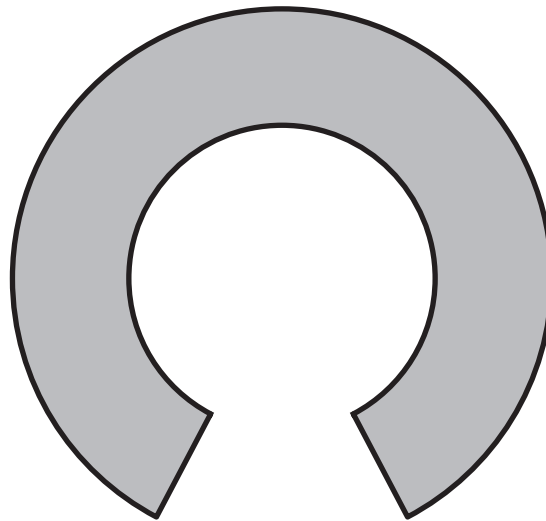
1

Directions: How many parts can this shape be split into using 1 line?
Find as many possible answers as you can.

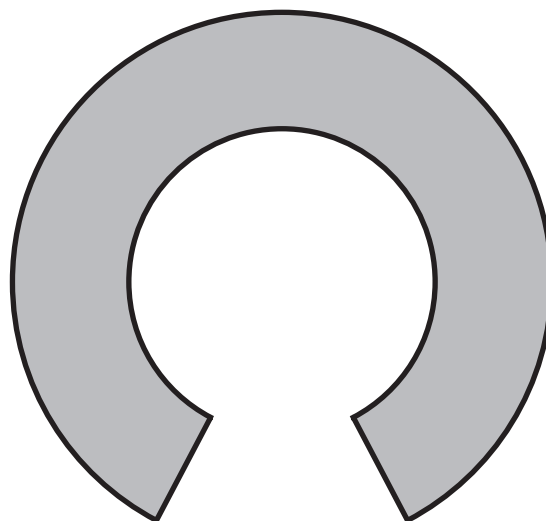

Directions: How many parts can this shape be split into using 2 lines? Find as many possible answers as you can.

Name

Date

2

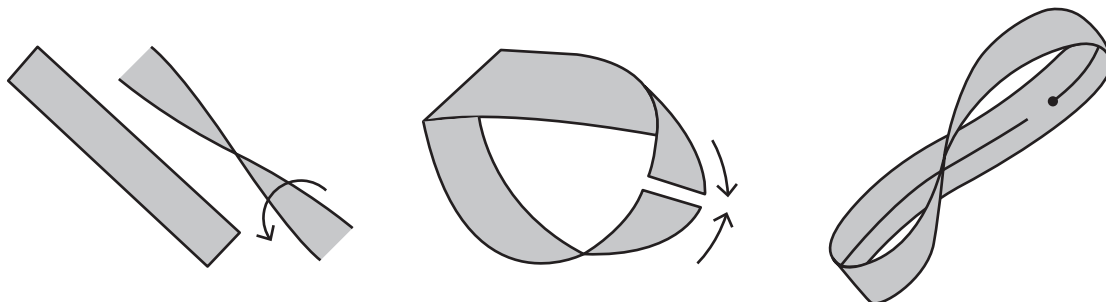

Directions: If you take a strip of paper, twist it half a turn, and glue or tape the ends together, you will create a shape known as a Möbius strip.

How many parts will you get if you cut this shape along the middle line?

Try to guess the result and then verify your answer by assembling and cutting it.



Investigations

Investigation 1

Counting Book



CC1 Sort and Describe Data CC2 How Many? CC3 Model With Numbers K.CC.3, K.CC.4, K.NBT.1, SMP.1, SMP.2, SMP.4, SMP.7

Task 1

Name _____

My Counting Book

1 Discuss

- I used _____ to show the number _____.
- I used _____ because _____.
- I can model _____ by ...



Task

2

Name _____

Representation Presentation

1

Discuss 

- I used _____ to show the number _____.
- I used _____ because _____.

2

Discuss 

- I noticed that _____ used _____.
- I like how _____ used _____ for _____.

Counting Book Directions

Students will create a counting book to represent numbers 1–20. Follow the steps to guide them through each unit as they complete their project.

1. Use the cover sheet and counting sheet on the next 2 pages to begin the counting book. As students add pages to represent numbers in different ways, encourage them to use the counting sheet or add clean sheets of paper to continue building their books.
2. **After Unit 2:** Students will use visual representations for numbers up to 10.
3. **After Unit 3:** Students will draw shapes to represent different numbers up to 10.
4. **After Unit 5:** Students will break up numbers 1–10 and write a matching simple equation.
5. **After Unit 6:** Students will add numbers 11–20 to their counting books. Numbers can be represented using 10-frames, numerals, or other math tools.

Name _____ Date _____

My Counting Book



Created By: _____

Investigation 2

2D Shape Town



CC1 Sort and Describe Data CC2 How Many? CC4 Shapes in the World Making Shapes From Parts

K.G.1, K.CC.5, K.CC.6, K.G.2, K.G.5, K.G.6, SMP.2, SMP.4, SMP.7

Task 1

Name _____

Sample Town

1 Discuss

- I notice ...
- I see ...
- A school has ...
- I made it using _____.
- I placed _____ above/below _____.

Task
2

Name _____



Classroom Community

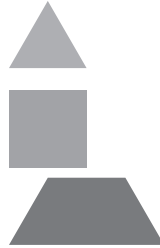

2 Use pattern blocks to create your building with

- 4 or more triangles
- 2 or more squares
- 2 or more trapezoids



How many of each block did you use?

| Pattern block | Number |
|---|-------------------------|
|  | _____ ----- _____ |
|  | _____ ----- _____ |
|  | _____ ----- _____ |

| Pattern block | Number |
|--|-------------------------|
|  | _____ ----- _____ |
|  | _____ ----- _____ |

Task
3

Name _____

Classroom Community

1 Discuss 

- I made a _____.
- I used _____ pattern blocks.
- One shape I made with smaller shapes was a _____.
- I made it using _____.
- I placed _____ above/below _____.

2 Discuss 

- I see _____.
- I notice _____.
- I count _____ blocks.
- How many _____?
- I wonder, _____?

Pattern Blocks

 **Directions:** Cut pattern blocks along the dotted lines. Distribute one set to each student.

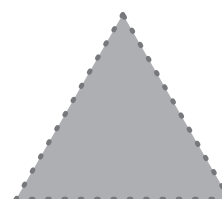
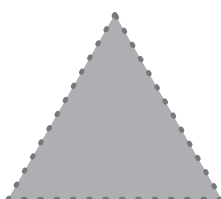
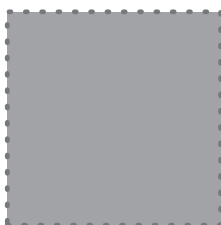
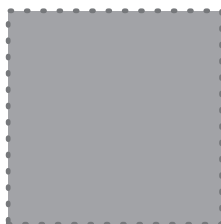
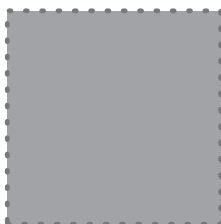
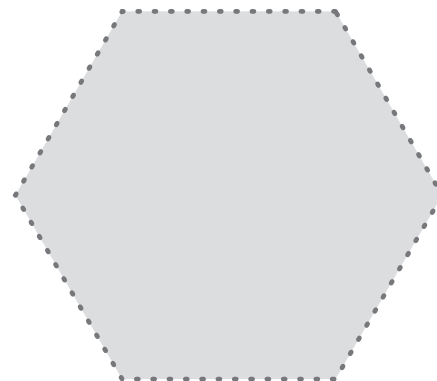
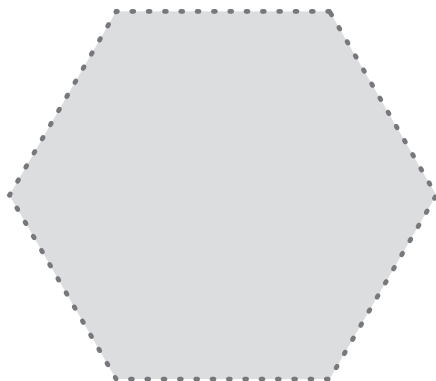
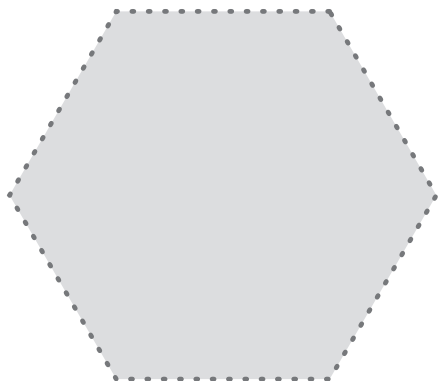

Pattern Blocks (continued)

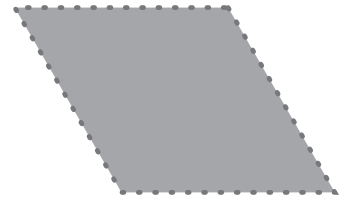
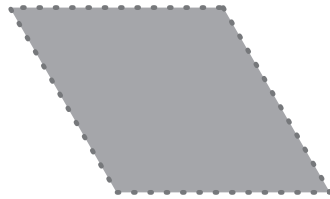
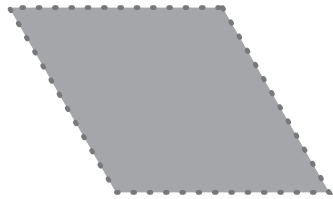
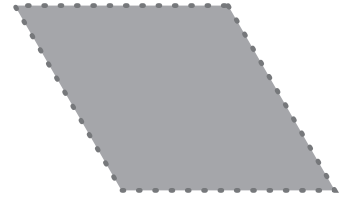
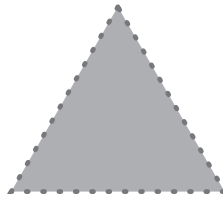
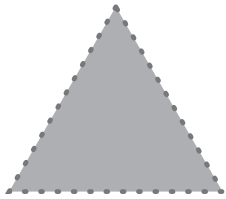

Name _____

My Building

Use the paper pattern blocks to create a building.

