

Amplify Desmos Math **CALIFORNIA**

Grade 1

**Math Language
Development Resources**

Contents

Unit 1: Adding, Subtracting, and Working With Data

Vocabulary Cards, Unit 1	2
1.01 Explore (Activity)	4
1.02 Shapes Ying Saw (Activity 2)	8
1.03 What Is Your Favorite Sea Animal? (Activity 2)	10
1.04 Show Us Your Data (Activity 2)	12
1.05 Aquarium Addition (Activity 2)	14
1.06 At the Aquarium (Activity 2)	16
1.07 What's the Sum? (Activity 2)	18
1.08 Buying Antiques (Activity 1)	20
1.09 Ying and Zora's Map (Activity 2)	22
1.10 Packing for a Picnic (Activity 2)	24
1.11 What's the Difference? (Activity 1)	26
1.12 Leaping Lily Pads! (Activity 2)	28
1.13 Data About the Fair (Activity 1)	30
1.14 What Can We Say About the Data? (Activity 2)	32
1.15 Can You Answer It? (Activity 2)	34

Contents (continued)

Unit 2: Addition and Subtraction Story Problems

Vocabulary Cards, Unit 2	36
2.01 Explore:Let's Grow! (Activity)	38
2.02 Tutu's Garden in Maui (Activity 1)	42
2.03 The Kalo Plants (Activity 1)	44
2.04 Replanting Huli (Activity 1)	46
2.05 A Community Working Together (Activity 2)	48
2.06 Helping Others (Activity 1)	50
2.07 So Many Worms! (Activity 2)	52
2.08 What Should We Plant? (Activity 1)	54
2.09 Organizing Supplies (Activity 2)	56
2.10 Max's Muffins (Activity 2)	58
2.11 Which Seed is Which? (Activity 2)	60
2.12 Making Them Equal (Activity 2)	62
2.13 Gardening Supplies (Activity 1)	64
2.14 How Many More? How Many Fewer? (Activity 1)	66
2.15 Different Amounts of Sunlight (Activity 1)	68
2.16 Ms. Perez's Survey Data (Activity 1)	70
2.17 Time to Harvest! (Activity 1)	72
2.18 Which Problem? (Activity 1)	74
2.19 A Problem in the Garden (Activity 1)	76
2.20 Garden Visitors (Activity 1)	78

Contents (continued)

Unit 3: Adding and Subtracting Within 20

Vocabulary Cards, Unit 3	80
3.01 Explore: Kenny's Recital (Activity)	82
3.02 So Many Sums! (Activity 1)	86
3.03 What's the Difference? (Activity 1)	88
3.04 Organizing Photos (Activity 1)	90
3.05 Same Number, Different Ways (Activity 1)	92
3.06 Decorating the Scrapbook (Activity 1)	94
3.07 Labeling Kenny's Photos (Activity 1)	96
3.08 Harmonica Practice (Activity 2)	98
3.09 Earning Music Money (Activity 2)	100
3.10 Family Photos (Activity 2)	102
3.11 Do They Have the Same Value? (Activity 1)	104
3.12 Making 10 (Activity 2)	106
3.13 Kitten Coaster (Activity 2)	108
3.14 Changing an Addend (Activity 2)	110
3.15 What Works For You? (Activity 2)	112
3.16 Kenny and His Stickers (Activity 1)	114
3.17 Getting to Ten (Activity 1)	116
3.18 Photos of Kenny (Activity 2)	118
3.19 What's Alike and Different? (Activity 1)	120
3.20 Adding and Subtracting Within 20 (Activity 2)	122

Contents (continued)

Unit 4: Numbers to 99

Words With Multiple Meanings	124
Vocabulary Cards, Unit 4	126
4.01 Explore: Game Points (Activity)	128
4.02 Meeting Yara (Activity 1)	132
4.03 It's a Match (Activity 1)	134
4.04 How Many Cubes? (Activity 2)	136
4.05 Boris's Thimbles (Activity 1)	138
4.06 How Many Tens? (Activity 1)	140
4.07 Meeting Prashant (Activity 1)	142
4.08 Curioso Collections (Activity 2)	144
4.09 Do They Show the Same Number? (Activity 1)	146
4.10 Curioso Customers (Activity 1)	148
4.11 Connecting With Collectors (Activity 1)	150
4.12 Steph's New Curioso Cards (Activity 1)	152
4.13 I See a Pattern (Activity 2)	154
4.14 Steph's Growing Collection (Activity 2)	156
4.15 Greater Than, Less Than (Activity 1)	158
4.16 Mystery Symbols (Activity 1)	162
4.17 Steph's Symbols (Activity 2)	164
4.18 Steph's Friends (Activity 2)	166
4.19 A Trip to the Flea Market (Activity 2)	168
4.20 Kat's Football Cards (Activity 2)	170
4.21 Collectors Everywhere! (Activity 1)	172
4.22 Collection Showcase! (Activity 1)	174

Contents (continued)

Unit 5: Adding Within 100

5.01 Explore: Squashes at the Playground (Activity)	176
5.02 From Park to Table (Activity 1)	180
5.03 Town Helpers (Activity 2)	182
5.04 Making Squash Butter (Activity 1)	184
5.05 Appreciating the Helpers (Activity 1)	186
5.06 Exploring a New Math Tool (Activity 1)	188
5.07 Using What You Know (Activity 1)	190
5.08 Special Deliveries (Activity 1)	192
5.09 Wazzle-Squash Crisps (Activity 2)	194
5.10 Sending Invitations (Activity 2)	196
5.11 Thinking About the Sum (Activity 1)	198
5.12 How Many Bags? (Activity 2)	200
5.13 Wazzle-Squash Festival (Activity 2)	202
5.14 Wazzle-Squash Data (Activity 1)	204

Contents (continued)

Unit 6: Measuring Lengths of Up to 120 Length Units

Vocabulary Cards, Unit 6	206
6.01 Explore: Build a Bird House (Activity)	208
6.02 Birds of a Feather (Activity 1)	212
6.03 A Very Muddy Competition (Activity 2)	214
6.04 Library Books (Activity 1)	216
6.05 Packing a Picnic (Activity 1)	218
6.06 Off to the Bird Sanctuary! (Activity 2)	220
6.07 From Wing Tip to Wing Tip (Activity 1)	222
6.08 Measuring More Wingspans (Activity 1)	224
6.09 From Head to Claws (Activity 2)	226
6.10 A Bird-Friendly Backyard (Activity 2)	228
6.11 Fascinated With Footprints (Activity 1)	230
6.12 Sharing Is Fun (Activity 1)	232
6.13 Addition or Subtraction? (Activity 1)	234
6.14 All Types of Problems (Activity 1)	236
6.15 Keeping Score (Activity 1)	238

Contents (continued)

Unit 7: Geometry and Time

Vocabulary Cards, Unit 7	240
7.01 Explore: Solid Shape Hunt (Activity)	244
7.02 Building With Nonna and Pia (Activity 2)	248
7.03 What Shapes Go With the Spotlight Shape? (Activity 1)	250
7.04 Drawing Flat Shapes (Activity 1)	252
7.05 Some Triangles, All Triangles (Activity 1)	254
7.06 Picky Eaters (Activity 1)	256
7.07 Building Shapes From Flat Shapes (Activity 1)	258
7.08 Dinner and Dessert (Activity 2)	260
7.09 Preparing Pierogies (Activity 2)	262
7.10 Fair and Square (Activity 1)	264
7.11 One of the Parts, All of the Parts (Activity 2)	266
7.12 A Bigger Part (Activity 1)	268
7.13 It's Time for Clocks (Activity 1)	270
7.14 Half Past (Activity 2)	272
7.15 The Minute Hand (Activity 2)	274
7.16 Writing Times (Activity 1)	278
7.17 Guess What Time It Is! (Activity 1)	280

Vocabulary Cards, Unit 1

 - **Directions:** Make enough copies so that each student receives one card for each term. Pre-cut the cards and distribute them during the lesson(s) in which the term is introduced.

category

A group of objects that are alike in some way.

Vocabulary Cards, Unit 1 · Lesson 2

conjecture

A statement that you believe is true based on current information.

Vocabulary Cards, Unit 1 · Lesson 7

data

Information about things or people in a group.

Vocabulary Cards, Unit 1 · Lesson 3

difference

The amount you get when you subtract one number from another.

$$10 - 6 = \textcircled{4}$$

Vocabulary Cards, Unit 1 · Lesson 10

equal

The same amount or value.

Vocabulary Cards, Unit 1 · Lesson 9

sum

The total when two or more numbers are added.

$$8 + 6 = \textcircled{14}$$

Vocabulary Cards, Unit 1 · Lesson 6

survey

A tool that can be used to collect information about a group of people's answers to the same question.

Vocabulary Cards, Unit 1 · Lesson 3

Name _____ Date _____

Ways to be a Mathematician

Formas de ser matemático/ matemática

- 1** I can take my time to think about a challenging problem before trying to solve it.

Puedo tomarme mi tiempo para pensar en un problema difícil antes de intentar resolverlo.



- 2** I can work carefully and try to be clear when I share my ideas.

Puedo trabajar con cuidado y tratar de ser claro/clara cuando comparto mis ideas.

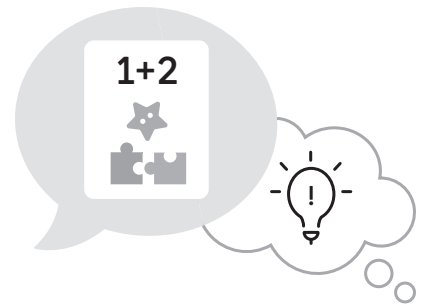

- 3** I can see how ideas are connected and use patterns to help solve problems.

Puedo ver cómo se conectan las ideas y utilizar patrones para ayudar a resolver problemas.

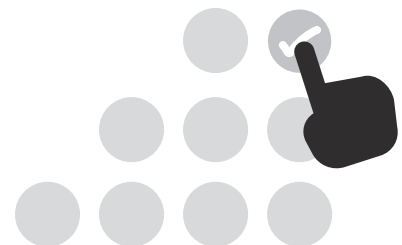

Name _____ Date _____

Questions and Sentence Frames

Why did you choose this statement?

Did you choose any others? Why or why not?

How did you use this thinking during the Activity?

Can you tell me more?

I chose this statement because . . .



I also chose _____ because . . .

In the Activity, I . . .

Name _____ Date _____

Creating Representations

Use with Activity 2.

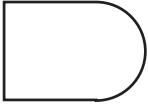
Shapes			
			
black square	white rectangle	gray circle	straight/curved

I represented each sorted shape with ...

I showed each category with ...

I can tell how many are in each category by ...

A data representation should include ...

My partner ...

Word bank	
English	Español
category	categoría
color	color
count	contar
data	datos
dots	punos
number	número
picture	dibujo
sort	ordenar
ordenar	símbolo
word	palabra
representation	representación

Name _____ Date _____

Organizing the Survey Data

Use with Problem 3.

Favorite Sea Animals		
 fish	 jellyfish	 turtle

I organized the cubes by . . .

It helps me count because . . .

Word bank	
English	Español
build	construir
category	categoría
color	color
count	contar
data	datos
sort	ordenar
stack	apilar
survey	encuesta
total	total
tower	torre

Name _____ Date _____

Comparing Representations

Use with Problem 2.

I see . . .

This _____ helps me understand the data because . . .
(feature)







Next time, I will try . . .

Word bank			
English	Español	English	Español
animal	animal	important	importante
amount	cantidad	label	rótulo
bar	barra	number	número
cube	cubo	picture	imagen
category	categoría	similar	similar
data	datos	sort	ordenar
different	diferentes	title	título
drawing	dibujo	total	total
feature	característica	tower	torre
graph	gráfica	word	palabra

Name _____ Date _____

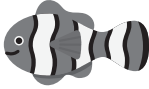
Matching Expressions

Use with Problem 3.

Sea Animals					
					
crab	dolphin	fish	jellyfish	octopus	turtle

My expression is . . .

Your expression is . . .

The first number
could represent . . .

The second number
could represent . . .







When thinking about addition
expressions, I notice . . .

Word bank	
English	Español
add	sumar
category	categoría
data	datos
different	diferente
expression	expresión
number	número
plus	más
same	mismo/igual
sum	suma
total	total
two	dos

Name _____ Date _____

Your Addition Stories

Use with Problem 3.

Sea Animals					
					
crab	dolphin	fish	jellyfish	octopus	turtle

1. Creating story problems	2. Telling story problems
The numbers in my story are ...	There are _____ and _____.
The animals in my story are ...	How many _____ are there?
3. Responding to story problems	
Your story problem matches the expression because ...	
The sum in your story problem is _____.	

Word bank					
English	altogether	different	number	same	total
Español	en total	diferente	número	mismo/igual	total

Name _____ Date _____

Mix and Mingle: Adding 1

Use with Problems 6 and 7.

The sum is . . .

To add 1, I . . .

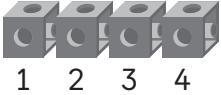
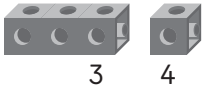
Word bank		
English	Español	Example Ejemplo
count all	contar todo	
count on	contar hacia adelante	

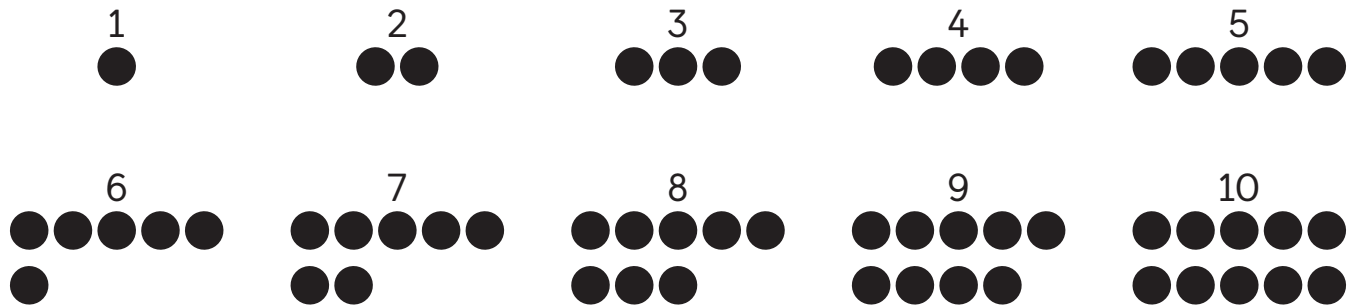

Conjecture

When you add 1, the sum is the next number in counting order.



I think the conjecture is true because . . .







I think the conjecture is false because . . .

Name _____ Date _____

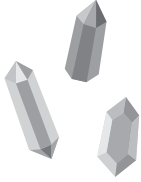
At the Antique Shop

Use with Problems 1–4.

Antiques			
 <p>crystal</p>	 <p>ring</p>	 <p>stone</p>	 <p>vase</p>

The story wanted me to find . . .

The label I included is . . .

To add 1, I . . .

To add 2, I . . .

I notice . . .

Word bank	
English	Español
add	sumar
count	contar
different	diferente
more	más
next	siguiente
number	número
order	orden
plus	más
same	igual
sum	suma

Name _____ Date _____

Is it Equal?

Use with Problems 2–5.

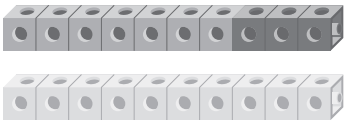
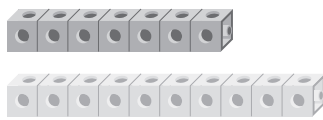
Definition	Characteristics
the same amount or value	It can be represented with the symbol =.
<div style="border: 1px solid gray; border-radius: 15px; padding: 5px; display: inline-block;"> equal igual </div>	
	
Example	Non-example

I notice _____, I wonder . . .

They both . . .

This one _____, while the other one . . .

I think the equation is true because . . . 





I think the equation is false because . . . 

Word bank	
English	Español
add	sumar
different	diferente
equation	ecuación
less	menos
more	más
same	igual
total	total
value	valor

Name _____ Date _____

Your Subtraction Stories

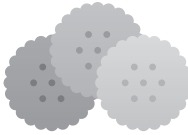
Use with Problem 3.

Picnic Food				
				
apple	catfish	cookie	grape	spring roll

1. Creating story problems	2. Telling story problems
The numbers in my story are ...	There are _____. Then ...
The food in my story is ...	How many _____ are left?
3. Responding to story problems	
Your story problem matches/does not match because ...	
The difference in your story problem is _____.	

Word bank					
English	count	difference	expression	same	subtract
Español	contar	diferencia	expresión	igual	restar

Name _____ Date _____

Subtraction Equations

Use with Activities 1 and 2.

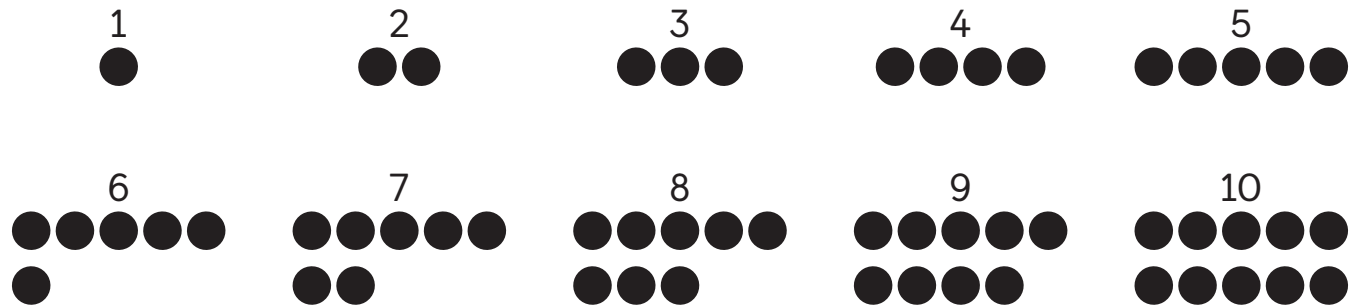

I notice all equations . . .

When subtracting 1, it is always true that . . .

To subtract 1, I . . .



I think the conjecture is true/false because . . .

Word bank	
English	Español
conjecture	conjecture
difference	difference
false	falso
less	menos
minus	menos
subtract	restar
take away	quitar
true	verdadero

Name _____ Date _____

Ying's Version

Use with Activity 2.

Adding 2	Subtracting 2
 <p style="text-align: center;">$6 + 2 =$</p>	 <p style="text-align: center;">$6 - 2 =$</p>

I notice . . .



Subtracting 2 and adding 2 are alike because . . .

Word bank	
English	Español
backwards	hacia atrás
count	contar
difference	diferencia
forward	hacia adelante
order	orden
subtract	sustraer
sum	suma
strategy	estrategia
total	total

Name _____ Date _____

Butter Sculpture Votes

Use with Problems 1–4.

Butter Sculpture		
 cow	 house	 goat

The _____ sculpture got _____ votes.

To find the amount of votes for 2 categories, I need to . . .



The statement is true because . . .



The statement is false because . . .



Another true statement is . . .

Word bank	
English	Español
add	sumar
altogether	en conjunto
category	categoría
data	datos
more	más
label	título
less	menos
sum	suma
title	título
total	total

Name _____ Date _____

Writing Your Own Statements

Use with Problems 3 and 4.

Butter Sculptures		
 cow	 house	 goat

The _____ sculpture got _____ votes.

There were a total of _____ votes for _____ and _____.

The addition equation would be _____.

I know this is true because . . .

Word bank	
English	Español
amount	cantidad
category	categoría
data	dato
equal	igual
equation	ecuación
label	título
number	número
plus	más
sort	ordenar
sum	suma
vote	voto

Name _____ Date _____

Asking and Answering Questions

Use with Problem 4.

We can answer this question because . . .

The answer is _____.

We cannot answer this question because . . .

To be able to answer this question, we would need to . . .

The most important question could be . . .

Word bank			
English	Español	English	Español
amount	cantidad	known	conocido
bar	barra	unknown	desconocido
category	categoría	label	leyenda
collect	recolectar	number	número
data	datos	picture	imagen
different	diferente	representation	representación
drawing	dibujo	tally	cuenta
feature	característica	title	título
graph	gráfico	topic	tema

Vocabulary Cards, Unit 2

✂ - **Directions:** Make enough copies so that each student receives one card for each term. Distribute the cards during Lesson 5.

addend

One of the numbers added together to find the sum.

$$\begin{array}{c} 5 + 6 = 11 \\ \uparrow \\ \text{addend} \end{array}$$

Vocabulary Cards, Unit 2 · Lesson 5

addend

One of the numbers added together to find the sum.

$$\begin{array}{c} 5 + 6 = 11 \\ \uparrow \\ \text{addend} \end{array}$$

Vocabulary Cards, Unit 2 · Lesson 5

addend

One of the numbers added together to find the sum.

$$\begin{array}{c} 5 + 6 = 11 \\ \uparrow \\ \text{addend} \end{array}$$

Vocabulary Cards, Unit 2 · Lesson 5

addend

One of the numbers added together to find the sum.

$$\begin{array}{c} 5 + 6 = 11 \\ \uparrow \\ \text{addend} \end{array}$$

Vocabulary Cards, Unit 2 · Lesson 5

addend

One of the numbers added together to find the sum.

$$\begin{array}{c} 5 + 6 = 11 \\ \uparrow \\ \text{addend} \end{array}$$

Vocabulary Cards, Unit 2 · Lesson 5

addend

One of the numbers added together to find the sum.

$$\begin{array}{c} 5 + 6 = 11 \\ \uparrow \\ \text{addend} \end{array}$$

Vocabulary Cards, Unit 2 · Lesson 5

addend

One of the numbers added together to find the sum.

$$\begin{array}{c} 5 + 6 = 11 \\ \uparrow \\ \text{addend} \end{array}$$

Vocabulary Cards, Unit 2 · Lesson 5

addend

One of the numbers added together to find the sum.

$$\begin{array}{c} 5 + 6 = 11 \\ \uparrow \\ \text{addend} \end{array}$$

Vocabulary Cards, Unit 2 · Lesson 5

Name _____ Date _____

Ways to be a Mathematician

Formas de ser matemático/ matemática

- 1** I can take my time to think about a challenging problem before trying to solve it.

Puedo tomarme mi tiempo para pensar en un problema difícil antes de intentar resolverlo.



- 2** I can use numbers, words, and diagrams to make sense of math ideas and situations.

Puedo usar números, palabras y diagramas para entender ideas y situaciones matemáticas.

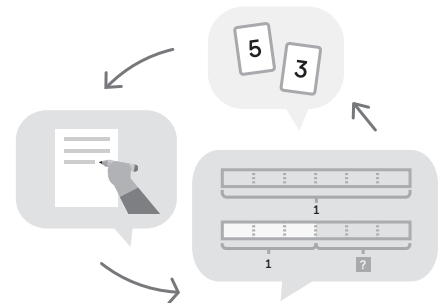

- 3** I can use math to help solve real-world problems.

Puedo usar las matemáticas para resolver problemas del mundo real.

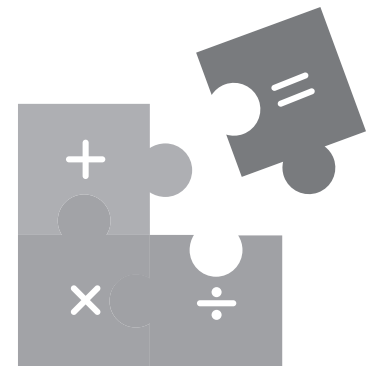

Name _____ Date _____

Questions and Sentence Frames

Why did you choose this statement?

Did you choose any others? Why or why not?

How did you use this thinking during the Activity?

Can you tell me more?

I chose this statement because . . .





I also chose _____ because . . .

In the Activity, I . . .

Name _____ Date _____

Kainoa's Guavas

Use with Problem 1.

Garden stories			
			
fruit	guava	juice	tree

The stories are alike because . . .

The stories are different because . . .

In Story problem A . . .





In Story problem B . . .

Word bank	
English	Español
add	sumar
amount	cantidad
change	cambiar
different	diferente
equation	ecuación
known	conocido
less	menos
more	más
result	resultado
same	mismo
subtract	restar
unknown	desconocido

Name _____ Date _____

Helping the Kalo Grow

Use with Problems 1 and 2.

Garden stories			
			
garden	kalo plant	kukui nut	tree

The story problem is about . . .

The starting amount is . . .

The amount changes by . . .

The equation represents the story problem because . . .





The _____ in the equation represents the _____ in the story problem.

Word bank	
English	Español
addition	suma
amount	cantidad
change	cambiar
ending	final
equation	ecuación
fall	caer
known	conocido
less	menos
more	más
subtract	restar
unknown	desconocido

Name _____ Date _____

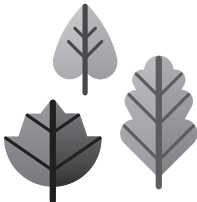
What Do You Want to Know?

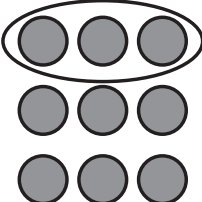
Use with Problem 1.

Garden stories			
 <p>leaves</p>	 <p>plant</p>	 <p>row</p>	 <p>stems</p>

A math question that I could ask about the story problem is . . .

In the beginning, how many . . .

During the middle of the story, how many . . .

At the end, how many . . .

Word bank	
English	Español
add	sumar
amount	cantidad
change	cambiar
end	final
equation	ecuación
less	menos
more	más
result	resultado
start	principio

Name _____ Date _____

Equations With Unknowns

Use with Problems 7–9.

Definition		Characteristics
One of the numbers added together to find the sum	addend sumando	Can be parts of a whole
$1 + 3 = 4$ ↑ ↑ addend		$1 + 3 = 4$ ↑ sum
Example		Non-Example

I know which equation matches because . . .

the known amounts are . . .

the unknown amount is . . .

I am trying to find the unknown _____.
(*addend/sum*)





The blank represents . . .

Word bank	
English	Español
change	cambiar
end	final
equation	ecuación
known	conocido
result	resultado
start	principio
sum	suma
unknown	desconocido

Name _____ Date _____

After the Storm

Use with Problems 1–3.

Garden stories			
			
branches	holes	plants	shovels

The starting amount is . . .

The change happens when . . .

The known is . . .

The unknown is . . .



The story problems are alike/
different because . . .

Word bank	
English	Español
addend	sumando
ending	final
equation	ecuación
larger	mayor
less	menos
more	más
result	resultado
smaller	más pequeño
starting	inicio
sum	suma

Name _____ Date _____

Two Different Equations

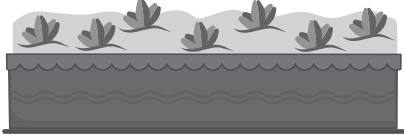
Use with Problem 2.

Garden stories	
 <p>garden bed</p>	 <p>worms</p>

This number represents . . .

The equations are alike because both . . .

The equations are different because . . .

I agree with _____
because . . . *(James/Lola/both)*





When adding, I notice . . .

Word bank	
English	Español
addend	sumando
amount	cantidad
part	parte
order	orden
sum	suma
total	total
whole	todo

Name _____ Date _____

Dani's and Max's Plans

Use with Problems 1 and 2.

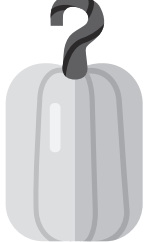
Garden stories				
				
beet	carrot	pumpkin	seeds	squash

The known is . . .

The unknown is . . .

This equation represents the story problem because . . .

The story problems are alike because . . .

The story problems are different because . . .

Word bank	
English	Español
addend	sumando
amount	cantidad
equation	ecuación
part	parte
result	resultado
sum	suma
total	total
whole	todo

Name _____ Date _____

Which Equation?

Use with Problem 5.

James' equation	Dani's equation
$3 + \underline{\quad} = 8$	$8 - 3 = \underline{\quad}$

I notice . . .

This number represents . . .

The equations are alike because . . .

The equations are different because . . .





Addition or subtraction can be used because . . .

Word bank	
English	Español
addend	sumando
amount	cantidad
equation	ecuación
known	conocido
part	parte
represent	representar
result	resultado
sum	suma
total	total
unknown	desconocido
whole	entero

Name _____ Date _____

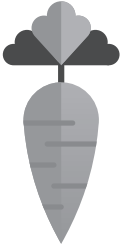
Which Problem Is It?

Use with Problem 3.

Garden stories			
			
carrot	muffin	squash	vegetables

I notice . . .

I think they solved Problem _____ because . . .

The representation is clear because . . .

The known value is represented by . . .

The unknown value is represented by . . .

Word bank	
English	Español
addend	sumando
difference	diferencia
equation	ecuación
label	título
number	número
picture	imagen
sum	suma
underline	subrayar
word	palabra

Name _____ Date _____

What Did Kainoa Plant?

Use with Problems 3–5.

Garden stories		
 broccoli	 pumpkin	 seeds

I notice . . .

The pattern I see is . . .

this addend . . . while that
addend . . .

Another way to organize is . . .

I know I have found all possible
answers because . . .

Word bank	
English	Español
addend	sumando
decrease	disminución
equation	ecuación
greatest	mayor
increase	incremento
least	menor
order	orden
pattern	patrón
sum	suma
total	total
whole	entero

Name _____ Date _____

Kainoa's Towers

Use with Problems 5 and 6.

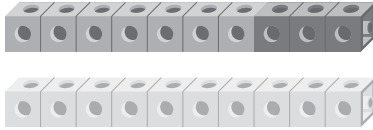
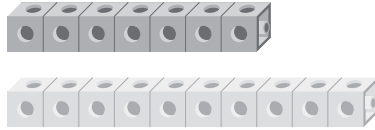
Definition	Characteristics
The same amount or value	It can be represented with the symbol =
	
Example	Non-Example

equal
igual

He could make the towers equal by _____ or by _____.

One way he could make the towers equal is by ...

This equation would be _____.

Another way to make the towers equal is by ...



This equation would be _____.

Word bank	
English	Español
add	suma
cube	cubo
red	rojo
subtract	restar
total	total
tower	torre
yellow	amarillo

Name _____ Date _____

Rakes in the Shed

Use with Problem 1.

Garden stories		
 rakes	 shed	 students

This story problem is different because:

It asks us to . . .

Some different words are . . .



To solve, I would . . .

Word bank	
English	Español
amount	cantidad
compare	comparar
difference	diferencia
fewer	menos
known	conocido
larger	más grande
less	menos
more	más
smaller	menor
unknown	desconocido

Name _____ Date _____

Comparing Carrots

Use with Problem 8.

Definition	Characteristics
Determine if amounts are equal, more, or less	Might use subtraction to find the difference
more →  fewer → 	 combine
Example	Non-Example

compare
comparar

compare

Dani picked _____ more carrots than Lola.

I know because . . .

The representation helps show . . .



If there was no picture, I could . . .

Word bank	
English	Español
difference	diferencia
draw	dibujar
fewer	menos
label	título
more	más
number	número
picture	imagen

Name _____ Date _____

Comparing Hours of Sunlight

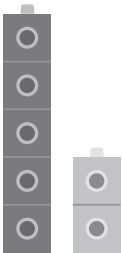
Use with Problem 1.

Definition	Characteristics
<p>The amount you get when you subtract one number from another.</p>	<p>“How much less?” “How many fewer?”</p>
 <p style="margin-left: 100px;">} difference</p>	 <p style="margin-left: 100px;">} combine</p>
<p>Example</p>	<p>Non-Example</p>

difference
diferencia

These equations are alike because ...

These equations are different because ...

This equation represents ...

The underlined number represents ...

To find the difference, you could _____ or _____.

Word bank	
English	Español
add	sumar
compare	comparar
fewer	menor cantidad
less	menos
more	más
subtract	restar

Name _____ Date _____

Asking Questions About Data

Use with Problems 1–3.

Garden stories		
 harvesting	 watering	 weeding

A question I could ask about 2 categories is . . .

How many more . . . ?

How many fewer . . . ?

How many total . . . ?

A question I could write is . . .

The answer to the question I wrote is _____ votes.

The equation for the question I wrote is _____.

I _____ 2 categories.
(combined/compared)

Word bank	
English	Español
addend	sumando
amount	cantidad
categories	categorías
combine	combinar
compare	comparar
data	datos
equation	ecuación
sum	suma
survey	encuesta
total	total
vote	voto

Name _____ Date _____

What Do You Know?

Use with Activity 1.

Garden stories				
				
basket	beet	bucket	carrot	pumpkin

The amounts I know are . . .

The amounts represent . . .

The relationship between the amounts is . . .

Word bank	
English	Español
amount	cantidad
difference	diferencia
fewer	menor cantidad
more	más
represent	representar

Name _____ Date _____

What's the Question?

Use with Problems 1 and 2.

Strategy	
 <p>combine</p>	 <p>compare</p>

The amounts in the stories are . . .

In this problem I am trying to find _____.



The stories are the same because . . .

Word bank	
English	Español
amount	cantidad
difference	diferencia
fewer	menos
more	más
story	historia
strategy	estrategia
total	total

Name _____ Date _____

Squirrels in the Garden

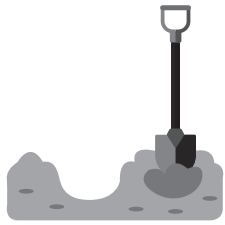
Use with Problems 1–5.

Garden stories			
			
carrot	holes	nut	squirrel

The amounts I know are ...

The unknown amount is _____.

The equations are the _____ because ...
(*same/different*)

Two different equations can represent the same story problem because ...

Word bank	
English	Español
amount	cantidad
different	diferente
equation	ecuación
fewer	menor cantidad
more	más
same	igual
unknown	desconocido

Name _____ Date _____

Can I Ask a Question?

Use with Problems 1–3.

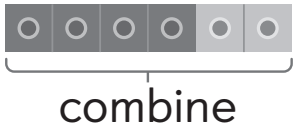
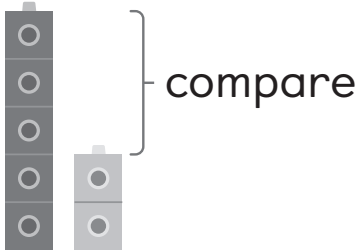
Strategy	
	

To compare groups, I could ask . . .

How many more _____ than _____?

How many fewer _____ than _____?

To combine groups, I could ask . . .

How many _____ put together?

How many in the _____ part?

Word bank	
English	Español
add	sumar
change	cambiar
group	grupo
how many	cuántos
question	pregunta
subtract	restar
than	que
together	juntos

Vocabulary Cards, Unit 3

 **Directions:** Make enough copies so that each student receives one card for each term. Pre-cut the cards and distribute them during the lesson(s) in which the term is introduced.

a one / ones

An amount that has a value of one. The plural of one is ones.

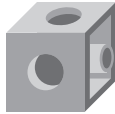

Vocabulary Cards, Unit 3 · Lesson 5

a ten / tens

A group of 10 ones. The plural of a ten is tens.



Vocabulary Cards, Unit 3 · Lesson 5

a one / ones

An amount that has a value of one. The plural of one is ones.

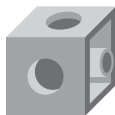

Vocabulary Cards, Unit 3 · Lesson 5

a ten / tens

A group of 10 ones. The plural of a ten is tens.



Vocabulary Cards, Unit 3 · Lesson 5

a one / ones

An amount that has a value of one. The plural of one is ones.

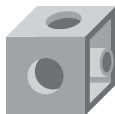

Vocabulary Cards, Unit 3 · Lesson 5

a ten / tens

A group of 10 ones. The plural of a ten is tens.



Vocabulary Cards, Unit 3 · Lesson 5

a one / ones

An amount that has a value of one. The plural of one is ones.

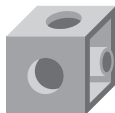

Vocabulary Cards, Unit 3 · Lesson 5

a ten / tens

A group of 10 ones. The plural of a ten is tens.



Vocabulary Cards, Unit 3 · Lesson 5

Name _____ Date _____

Ways to be a Mathematician

Formas de ser matemático/ matemática

- 1 I can take my time to think about a challenging problem before trying to solve it.

Puedo tomarme mi tiempo para pensar en un problema difícil antes de intentar resolverlo.



- 2 I can see how ideas are connected and use patterns to help solve problems.

Puedo ver cómo se conectan las ideas y utilizar patrones para resolver problemas.



- 3 I look for strategies that I can apply to new problems.

Busco estrategias que puedo aplicar a nuevos problemas.

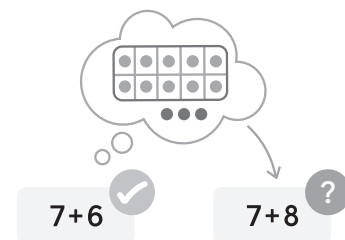

Name _____ Date _____

Questions and Sentence Frames

Why did you choose this statement?

Did you choose any others? Why or why not?

How did you use this thinking during the Activity?

Can you tell me more?

I chose this statement because . . .

I also chose _____ because . . .

In the Activity, I . . .

Name _____ Date _____

Patterns With Addition

Use with Problem 3.

Definition	Characteristics
<p>The total when 2 or more numbers are _____.</p>	<p>“total” “whole”</p>
<p>sum suma</p>	
<p>$1 + 3 = 4$ ↑ sum</p>	<p>$1 + 3 = 4$ ↑ ↑ addends</p>
Example	Non-example

The sum is _____.

The addition strategy I used is _____.

The pattern I notice is . . .

A conjecture I can make is . . .

Word bank	
English	Español
addend	sumando
conjecture	conjetura
count all	contar todo
count on	contar hacia adelante
pattern	patrón
total	total

Name _____ Date _____

Patterns With Subtraction

Use with Problem 3.

Definition	Characteristics
<p>The amount you get when you _____ one number from another.</p>	<p>“How much less?” “How many fewer?”</p>
<p>difference diferencia</p>	
<p>Example</p>	<p>Non-example</p>

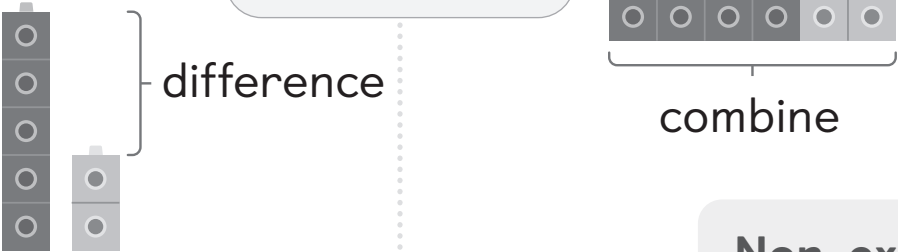

The difference is _____.

The subtraction strategy I used is _____.

The pattern I notice is . . .

A conjecture I can make is . . .

Word bank	
English	Español
conjecture	conjetura
count back	contar hacia atrás
less	menos
more	más
pattern	patrón

Name _____ Date _____

Kenny's Helpful Equations

Use with Problems 1–5.

Part-Part-Whole Chart	
whole	
part	part

Addition and Subtraction
$P + P = W$
$W - P = P$

I notice . . .

To match, I can look for . . .

$9 = 4 + 5$ helps me find the difference _____ = $9 - 5$ because . . .



One way to find an unknown difference is . . .

Word bank	
English	Español
addend	sumando
difference	diferencia
equation	ecuación
part	parte
strategy	estrategia
sum	suma
total	total
whole	todo

Name _____ Date _____

Representing a Teen Number

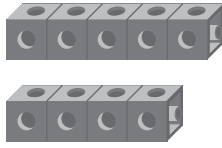
Use with Problems 1–3.

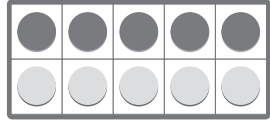
Math tools			
 <p>counters</p>	 <p>cubes</p>	 <p>tower</p>	 <p>10-frame</p>

One way to represent a teen number is with _____.

Another way to represent a teen number is with _____.

They are alike because ...

They are different because ...

I notice that a teen number can be represented ...

Word bank	
English	Español
different	diferente
dots	puntos
group	grupo
a one	una unidad
ones	unidades
representation	representación
similar	similar
a ten	una decena

Name _____ Date _____

Kenny's Buttons

Use with Problems 1 and 2.

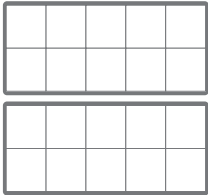
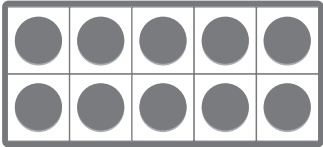
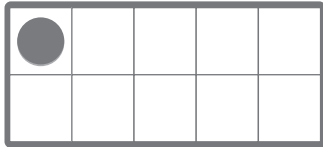
Math language		
		
double 10-frame	a ten	a one

I can represent the number using the double 10-frame by ...

The equation to match the double 10-frame can be _____.



I notice all the equations ...

Word bank	
English	Español
10-frame	marco de 10
addend	sumando
double 10-frame	doble 10 cuadros
a one	una unidad
ones	unidades
representation	representación
sum	suma
a ten	una decena
total	total

Name _____ Date _____

Kenny's Special Pens

Use with Problems 1 and 2.

Scrapbook story		
		
case	pen	photos

A question that I can ask about the story is . . .

In the beginning,
how many . . .

During the middle of the
story, how many . . .

At the end, how many . . .



It would be helpful to have
information about . . .

Word bank	
English	Español
add	sumar
amount	cantidad
change	cambiar
end	final
equation	ecuación
initial	inicial
less	menos
more	más
result	resultado
start	principio

Name _____ Date _____

Adding Minutes

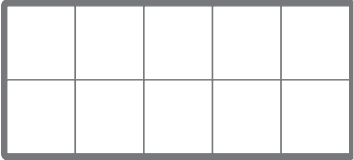
Use with Problems 3–7.

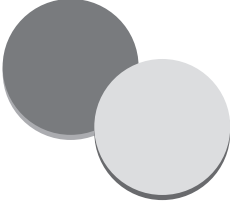
Math tools		
		
10-frame	cubes	counters

I used _____ to model the equation.

First, I . . .

Then I . . .

I noticed . . .



I know that _____ and _____ equals _____.

Word bank	
English	Español
add	sumar
equation	ecuación
group	grupo
a one	una unidad
ones	unidades
part	parte
representation	representación
a ten	una decena
total	total

Name _____ Date _____

Kenny's Savings

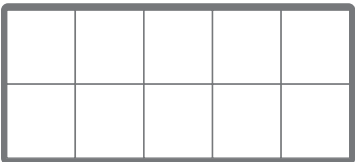
Use with Problems 3–7.

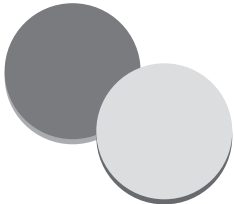
Math tools		
		
10-frame	cubes	counters

I used _____ to model the equation.

First, I . . .

Then I . . .

I noticed . . .

I know that _____ and _____ equals _____.

Word bank	
English	Español
add	sumar
equation	ecuación
group	grupo
ones	unidades
part	parte
representation	representación
subtract	sustraer
take away	quitar
a ten	una decena
total	total

Name _____ Date _____

Taking Photos

Use with Problems 4–6.

Math strategy	
<p style="text-align: center;"> $\begin{array}{r} 7 + 5 + 2 \\ \downarrow \swarrow \\ 12 \\ \downarrow \searrow \\ 12 + 2 = 14 \end{array}$ </p> <p style="text-align: center;">add the numbers in the order they appear</p>	<p style="text-align: center;"> $\begin{array}{r} 7 + 5 + 2 \\ \downarrow \quad \downarrow \swarrow \\ \quad 7 \\ \downarrow \swarrow \\ 7 + 7 = 14 \end{array}$ </p> <p style="text-align: center;">change the order to make a known sum</p>

The story was asking me to find . . .

First, I added _____ because . . .

Then I _____ because . . .

Another strategy is to . . .

These strategies are similar because . . .

These strategies are different because . . .

Word bank	
English	Español
add	sumar
addend	sumando
double	doble
equation	ecuación
a one	una unidad
ones	unidades
sum	suma
a ten	una decena
total	total

Name _____ Date _____

Matching Expressions

Use with Problems 1–5.

Definition	Characteristics
When 2 numbers are added to equal 10.	Consistent pairs
<div style="border: 1px solid gray; border-radius: 15px; padding: 5px; display: inline-block;"> make 10 sumar 10 </div>	
<p>Example</p> $1 + 9 = 10$ $2 + 8 = 10$ $3 + 7 = 10$ $4 + 6 = 10$ $5 + 5 = 10$	$3 + 4 = 7$ <p>Non-example</p>

I notice . . .

I need to know the _____.

I can look for . . .

___ + ___ + ___ has the same value as $10 + \underline{\quad}$ because . . .

Word bank	
English	Español
add	sumar
addend	sumando
equation	ecuación
expression	expresión
ones	unidades
strategy	estrategia
sum	suma
a ten	una decena
total	total

Name _____ Date _____

After-School Scrapbooking

Use with Problems 4–6.

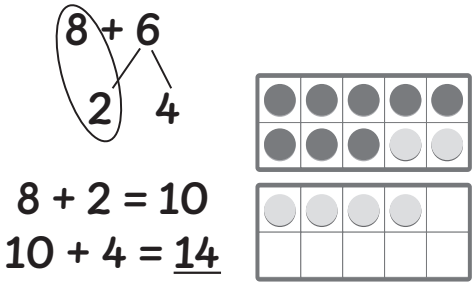
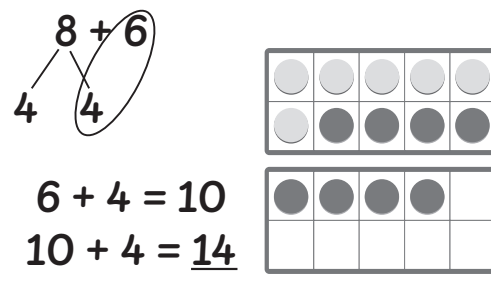
Make a 10	
 <p> $8 + 6 = 14$ $8 + 2 = 10$ $10 + 4 = 14$ </p>	 <p> $8 + 6 = 14$ $6 + 4 = 10$ $10 + 4 = 14$ </p>

The story was asking me to find . . .

First, I _____, and then I _____.

Another strategy is to . . .

These strategies are similar because . . .

These strategies are different because . . .

Word bank	
English	Español
add	sumar
addend	sumando
break	partir
decompose	descomponer
equation	ecuación
a one	una unidad
ones	unidades
sum	suma
a ten	una decena
total	total

Name _____ Date _____

All Kittens Aboard

Use with Activity 2.

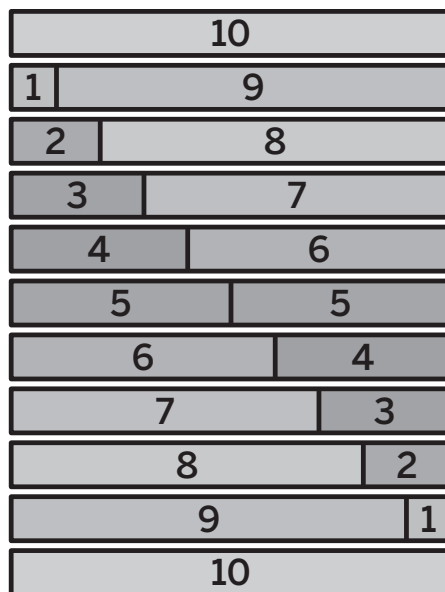

I am trying to find . . .

First, I . . .

Next, I . . .

I know that _____ makes the equation true because . . .

Word bank	
English	Español
add	sumar
addend	sumando
break	partir
decompose	descomponer
equation	ecuación
strategy	estrategia
sum	suma
a ten	una decena
total	total

Name _____ Date _____

What Should Jules Do Next?

Use with Problems 3–6.

Make 10	Doubles	
$1 + 9 = 10$	$1 + 1 = 2$	$6 + 6 = 12$
$2 + 8 = 10$	$2 + 2 = 4$	$7 + 7 = 14$
$3 + 7 = 10$	$3 + 3 = 6$	$8 + 8 = 16$
$4 + 6 = 10$	$4 + 4 = 8$	$9 + 9 = 18$
$5 + 5 = 10$	$5 + 5 = 10$	$10 + 10 = 20$

First, Jules . . .

The strategy was _____.

Next, Jules needs to _____
because . . .The equation for this next
step is _____.

The sum is _____.

Another strategy is . . .

Word bank	
English	Español
add	sumar
addend	sumando
break	partir
decompose	descomponer
equation	ecuación
known	conocido
strategy	estrategia
subtract	sustraer
sum	suma
total	total
unknown	desconocido

Name _____ Date _____

Two Different Ways

Use with Problem 3.

Math strategy	
$\begin{array}{c} \underline{7} + \underline{5} + 2 \\ \swarrow \quad \searrow \quad \downarrow \\ 12 \quad \quad \quad \\ \downarrow \\ 12 + 2 = 14 \end{array}$ <p>add the numbers in the order they appear</p>	$\begin{array}{c} 7 + \underline{5} + \underline{2} \\ \downarrow \quad \quad \swarrow \quad \searrow \\ \quad \quad \quad 7 \quad \quad \quad \\ \downarrow \\ 7 + 7 = 14 \end{array}$ <p>change the order to make a known sum</p>

For the first strategy, I . . .

For the second strategy, I . . .

The strategies I used were the same because . . .

The strategies I used were different because . . .

My partner . . .

Next time, I want to try . . .

Word bank	
English	Español
add	sumar
addend	sumando
break	partir
decompose	descomponer
double	doble
equation	ecuación
known	conocido
strategy	estrategia
sum	suma
total	total
unknown	desconocido

Name _____ Date _____

A Sticker Situation

Use with Activity 1.

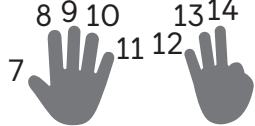
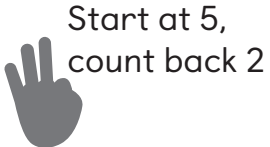
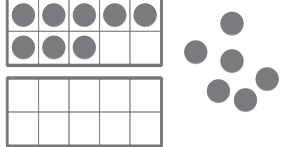
Subtraction strategy			
 <p>cross out</p>	 <p>count on</p>	 <p>count back</p>	 <p>take away</p>

To find the difference, I can ...

Another strategy is ...

My partner ...

The strategy I like to use is _____ because ...

I want to practice ...

Word bank	
English	Español
break	partir
count	contar
decompose	descomponer
difference	diferencia
equation	ecuación
known	conocido
left	el resto
total	total
unknown	desconocido

Name _____ Date _____

Setting the Stage

Use with Problem 2.

Subtraction strategy

Kenny's work

$$\begin{array}{r}
 16 - 7 \\
 \swarrow \searrow \\
 6 \quad 1 \\
 16 - 6 = 10 \\
 10 - 1 = 9
 \end{array}$$

I notice ...

I wonder ...

First, Kenny ...

Next, ...

I think Kenny subtracted this way because ...

When I subtract, I ...

Word bank

English	Español
break	partir
count	contar
decompose	descomponer
difference	diferencia
equation	ecuación
known	conocido
left	el resto
strategy	estrategia
subtract	sustraer
total	total
unknown	desconocido

Name _____ Date _____

How Did You Solve?

Use with Problems 3–7.

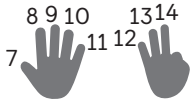
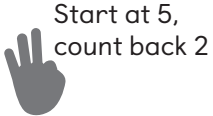
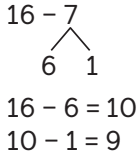
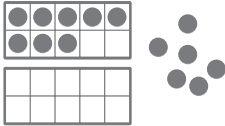
Subtraction strategy				
 <p>cross out</p>	 <p>count on</p>	 <p>count back</p>	$16 - 7$  <p>get to 10</p>	 <p>take away</p>

The strategies I used to solve all the problems were _____.

For Problem _____, I . . .

I used this strategy because . . .

I used the same strategy for Problems _____ and _____.

To decide which strategy to use, I . . .

Word bank	
English	Español
break	partir
decompose	descomponer
difference	diferencia
different	diferente
equation	ecuación
left	el resto
less	menos
more	más
ones	unidades
same	mismo
a ten	una decena
total	total

Name _____ Date _____

Comparing Story Problems

Use with Problems 1 and 2.

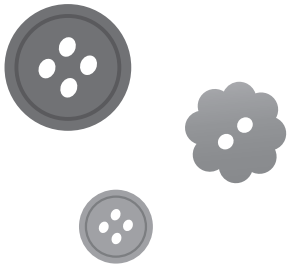
Scrapbook story
 <p>buttons</p>

Story problem _____ is about ...

The known amounts are ...

The unknown amount is ...

The story problems are alike because they both _____.



The story problems are different because in Story problem A _____, but in Story problem B _____.

Word bank	
English	Español
alike	similar
amount	cantidad
change	cambiar
difference	diferencia
end	final
known	conocido
less	menos
more	más
result	resultado
start	principio
unknown	desconocido

Name _____ Date _____

All Kinds of Equations

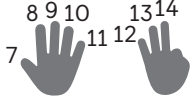
Use with Problems 4–9.

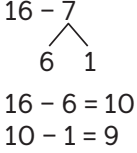
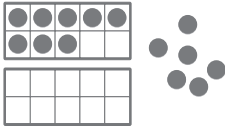
Subtraction strategy				
 <p>cross out</p>	 <p>count on</p>	 <p>Start at 5, count back 2</p> <p>count back</p>	$16 - 7$  <p>get to 10</p>	 <p>take away</p>

I notice the numbers are . . .

To solve the problem, I . . .

I chose this strategy
because . . .

To decide which strategy to
use, I . . .

What do you mean by . . . ?

Why did you . . . ?

Word bank	
English	Español
break	partir
decompose	descomponer
difference	diferencia
different	diferente
equation	ecuación
left	el resto
less	menos
more	más
same	mismo
total	total

Name _____ Date _____

Words With Multiple Meanings

Draw a picture or write in words to show the math meaning and another meaning of the term.

Math meaning

digit

Another meaning

Vocabulary Cards, Unit 4

✂ - **Directions:** Make enough copies so that each student receives one card for each term. Pre-cut the cards and distribute them during the lesson(s) in which the term is introduced.

digit

Any of the numbers 0 through 9.

0 1 2 3 4 5 7 8 9

Vocabulary Cards, Unit 4 · Lesson 8

estimate

A guess you make about a value based on what you know.

Vocabulary Cards, Unit 4 · Lesson 3

greater than

Words used when comparing. 9 is greater than 3, because 9 things are more than 3 things.

Vocabulary Cards, Unit 4 · Lesson 14

less than

Words used when comparing. 3 is less than 9, because 3 things aren't as many as 9 things.

Vocabulary Cards, Unit 4 · Lesson 14

a ten / tens

A group of 10 ones. The plural of a ten is tens.



Vocabulary Cards, Unit 4 · Lesson 3

Name _____ Date _____

Ways to be a Mathematician

Formas de ser matemático/ matemática

- 1** I can take my time to think about a challenging problem before trying to solve it.

Puedo tomarme mi tiempo para pensar en un problema difícil antes de intentar resolverlo.



- 2** I can see how ideas are connected and use patterns to help solve problems.

Puedo ver cómo se conectan las ideas y utilizar patrones para resolver problemas.

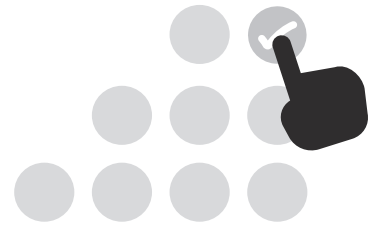

- 3** I look for strategies that I can apply to new problems.

Busco estrategias que puedo aplicar a nuevos problemas.

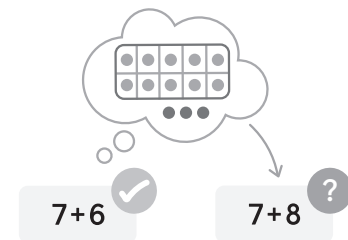

Name _____ Date _____

Questions and Sentence Frames

Why did you choose this statement?

Did you choose any others? Why or why not?

How did you use this thinking during the Activity?

Can you tell me more?

I chose this statement because . . .

I also chose _____ because . . .

In the Activity, I . . .

Name _____ Date _____

Yara's Guitar Picks

Use with Activities 1 and 2.

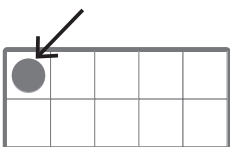
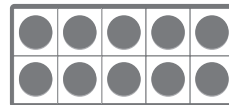
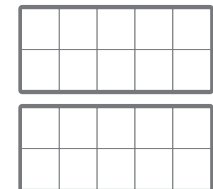
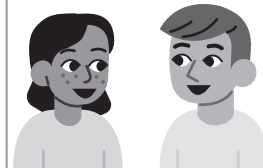
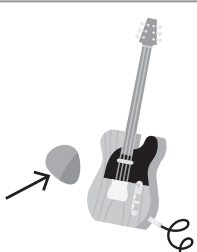
				
a one	a ten	double 10-frame	pair of students	guitar pick

I think we should organize the collection by _____ because _____.

I can organize the groups by ...

This helped us count because ...

Using groups of 10 is helpful because ...

We organized the collection by ...

Our pair/their pair organized the objects by ...

Our pair/their pair counted the objects by ...



Both of the pairs ...

Word bank	
English	Español
collection	colección
count	contar
flea market	mercadillo
group	grupo
object	objeto
organize	organizar

Name _____ Date _____

Representations of Tens

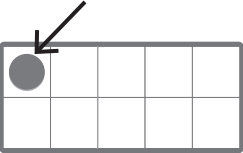
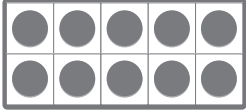
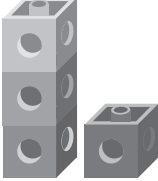
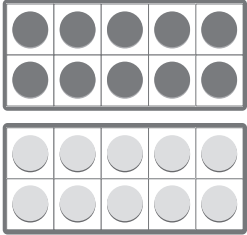
Use with Activities 1 and 2.

Math tools				
				
a one	a ten	cubes	tens	tower



This card is the same as that card because . . .



We know all of these cards represent the same number because . . .
they are all equal to _____.





I know the cubes represent _____ because . . .
I built _____ towers of ten.
there are _____ tens in _____.

Word bank			
English	both	equal	represent
Español	ambos	igual	representar

Name _____ Date _____

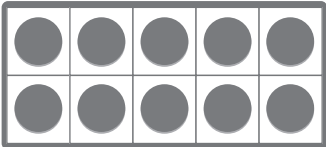
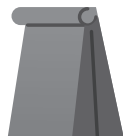
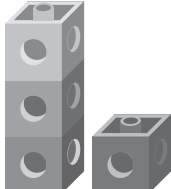

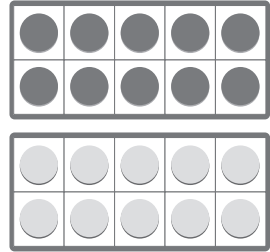
Adding a Ten, Subtracting a Ten

Use with Activity 2.

 <p>a ten</p>	 <p>bag</p>	 <p>cubes</p>
 <p>pattern</p>	 <p>tens</p>	 <p>tower</p>

I notice the  _____ are the numbers I say when I
(*sums / differences*)

count _____ by ...
(*on / back*)





Counting strategies	
 <p>Start at 5, count back 2</p> <p>counting back</p>	<p>8 9 10 13 14</p>  <p>7</p>  <p>11 12</p> <p>counting on</p>

Word bank	
English	Español
change	cambiar
difference	diferencia
left	quedar
sum	suma

Name _____ Date _____

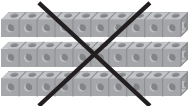
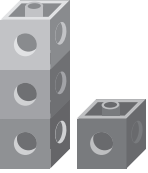
Counting Thimbles

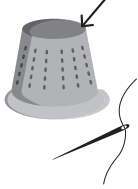
Use with Activities 1 and 2.

Boris' representations					
					
box	cross out	cubes	drawing	thimble	tower

I can represent Boris' drawings by . . .



When I cross out a tower, I am _____ by . . .
(adding / subtracting)

There are _____ towers of ten left.

The strategy I chose is . . .

My strategy is like theirs because . . .

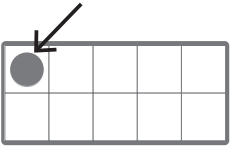
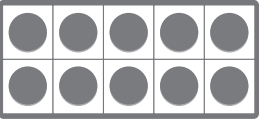

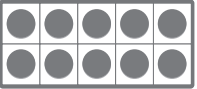
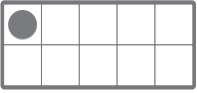
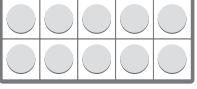

My strategy is different from theirs because . . .

Pieces		Word bank	
 a one	 a ten	English	Español
		both	ambos
		difference	diferencia
ones	tens	sum	suma
		total	total

Name _____ Date _____

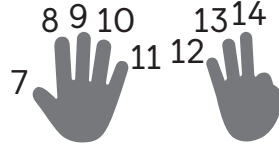
Adding Tens

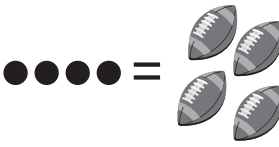
Use with Activities 1 and 2.

 <p>Start at 5, count back 2</p> <p>count back</p>	 <p>7 8 9 10 11 12 13 14</p> <p>count on</p>	 <p>coupon</p>	$2 + 3 = 5$ <p>equation</p>
<p>+</p> <p>plus</p>	 <p>representation</p>	 <p>tower of ten</p>	 <p>underline</p>

My representation shows . . .

My equation is . . .

The answer is _____.

I prefer _____ because . . .

I like _____ because . . .



Word bank	
English	Español
add	sumar
difference	diferencia
subtract	sustraer
sum	suma

My strategy is _____ theirs because . . .
(like / different from)

Name _____ Date _____

Prashant's Cards

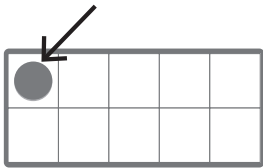
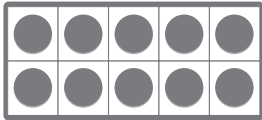
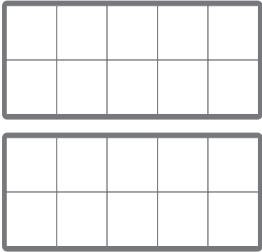
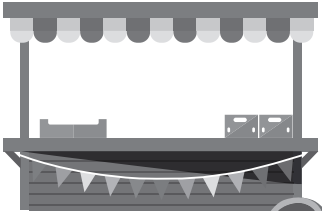
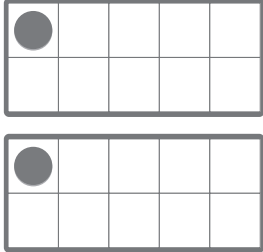
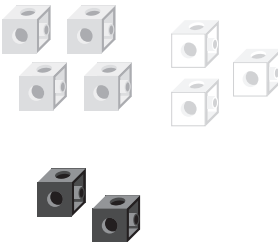
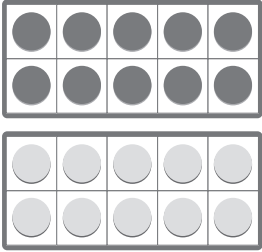
Use with Activities 1 and 2.

Organizing objects			The flea market
 a one	 a ten	 double 10-frame	 booth
 ones	 organize	 tens	 cards

I have _____ objects in my collection.

They are alike because . . .

They are the same because . . .

They are different because . . .

I know there are _____ objects in this collection because . . .

Word bank

English	Español
collection	colección
remain	quedar

Name _____ Date _____

Who Do You Agree With?

Use with Activity 2.

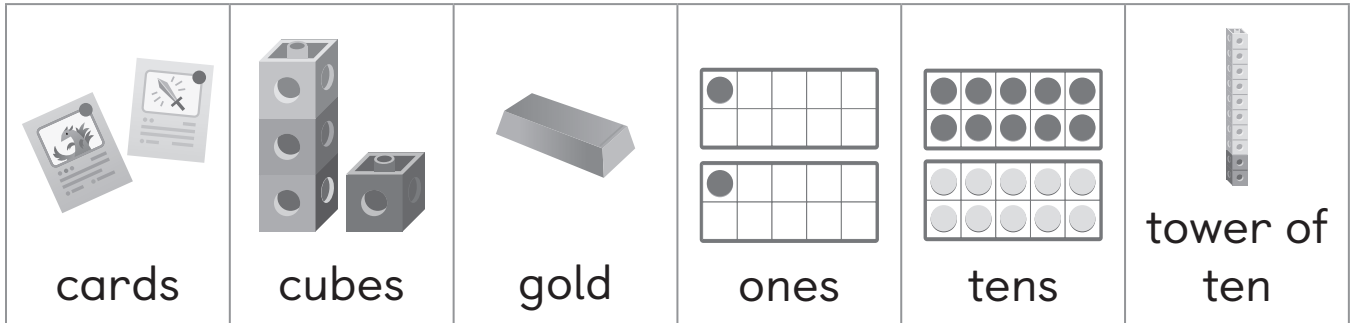



I agree with _____ because I see _____ tens
(Steph / the other visitor)
and _____ ones.



The digit on the _____ is the number of _____.
(left / right) (tens / ones)

I can draw _____ towers of ten and _____ cubes.





Word bank	
English	Español
digit	dígito

Sides	
 left	 right

Name _____ Date _____

Representation Tour

Use with Activities 1 and 2.



Do you agree?		Sides	
			
yes	no	left	right

I know they _____ show the same number because . . .
(do / do not)

one has _____ of tens/ones.

the other has _____ of tens/ones.

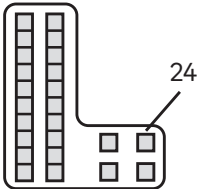
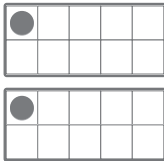
The drawing has _____ tens and _____ ones.

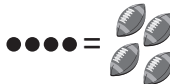
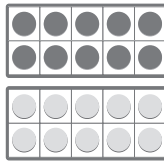
Word bank						
English	digit	match	ones	pair	represent	tens
Español	dígito	emparejar	unidades	pareja	representar	decenas
Example Ejemplo	18					

Name _____ Date _____

How Much?

Use with Activities 1 and 2.

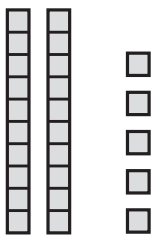
Ways to represent a two-digit number			
 <p>cubes</p>	$20 + 5 = 25$ expression	25 numbers	2 5 tens ones words



I noticed . . .

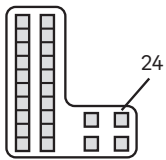

so I matched . . .



There are _____ (number) _____ (tens / ones)

The digit on the _____ (left / right)

represents _____ (tens / ones)

I represented the number using . . .

Word bank	
English	Español
customer	cliente
digit	dígito
equation	ecuación
ones	unidades
tens	decenas

Sides	
 <p>left</p>	 <p>right</p>

Name _____ Date _____

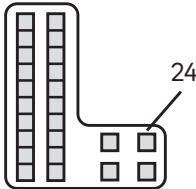
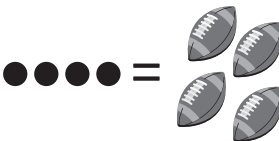

Writing Two-Digit Numbers

Use with Activities 1 and 2.

Word bank				
English	card	digit	match	representation
Español	tarjeta	dígito	emparejar	representación
Example Ejemplo		1 <u>8</u>		

I wrote _____.

I know the number matches the representation because . . .

Sides	
 left	 right

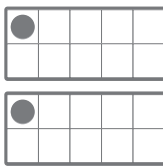
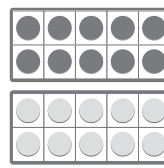
Pieces	
 ones	 tens

Name _____ Date _____

Opening Booster Packs

Use with Activities 1 and 2.

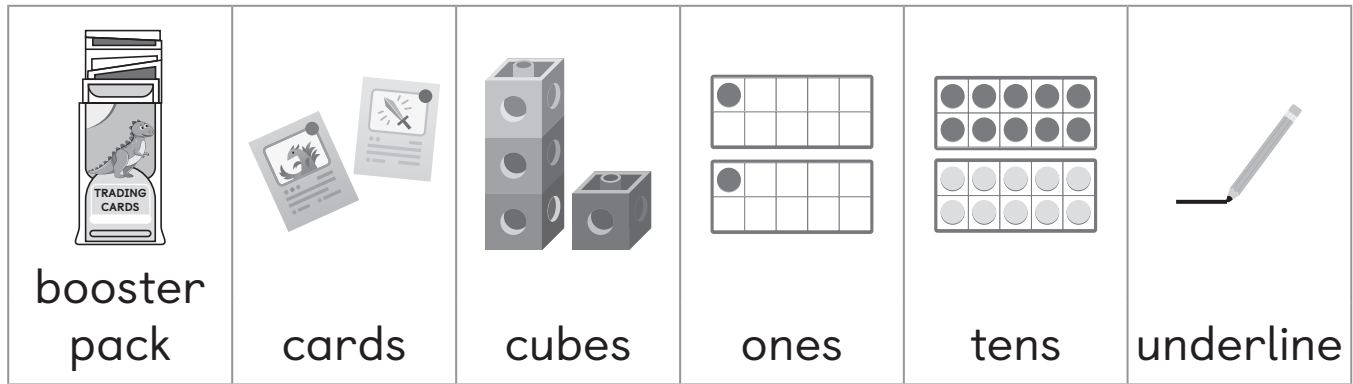

The strategy I used was . . .

My strategy is _____
(like / different from)
theirs because . . .

I found the sum for
Problem 7 by . . .

Word bank	
English	Español
digit	dígito
equation	ecuación
expression	expresión
true	verdadero
sum	suma

Name _____ Date _____

Patterns With Tens

Use with Activity 2.

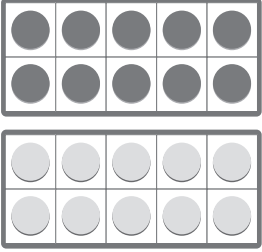
+	$2 + 3 = 5$	-	
add	equation	subtract	tens



I notice ...



I can use patterns ...

each time 10 is added ...

each time 10 is subtracted ...

I know ...

My thinking changed ...

because ...

because ... they did ...

I learned ...



I shared ...

Word bank	
English	Español
column	columna
conjecture	conjetura
difference	diferencia
digit	dígito
equation	ecuación
less	menos
more	más
sum	suma

Name _____ Date _____

Greater Than or Less Than?

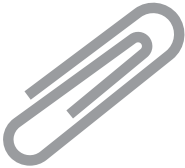
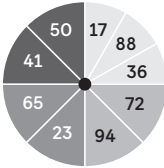
Use with Activity 2.

Spin!		
 paper clip	 spinner	 spins

To *compare* means . . .



I notice _____ has _____ tens and _____ ones.
(number)

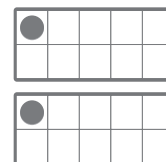
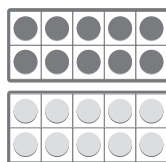

I know _____ is _____ than _____ because . . .
(number) (greater / less) (number)

Word bank					
English	compare	greater than	less	less than	more
Español	comparar	mayor que	menos	menor que	más

Name _____ Date _____

Comparing Curioso Cards

Use with Activities 1 and 2.

All the numbers that are _____ than ...
(greater / less)

I know _____ is _____ than _____ because ...
(greater / less)

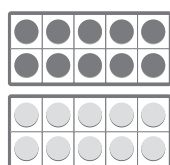

it has _____ tens.

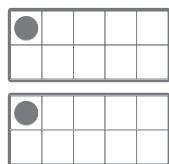

it has _____ ones.

I think the conjecture is _____ because ...
(true / false)

Word bank

English	Español	English	Español
compare	comparar	false	falso
conjecture	conjetura	true	verdadero
digit	dígito		

Name _____ Date _____

Comparing Curioso Cards (continued)





Definition	Characteristics
Words used when comparing	>
greater than mayor que	
9 is greater than 3 because 9 things are more than 3 things.	3 is greater than 7 because 3 things are fewer than 7 things.
Example	Non-Example

Definition	Characteristics
Words used when comparing	<
less than mayor que	
3 is less than 9 because 3 things are not as many as 9 things.	3 is less than 9 because 3 things are more than 9 things.
Example	Non-Example

Name _____ Date _____

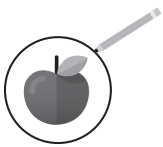
Symbol Tour

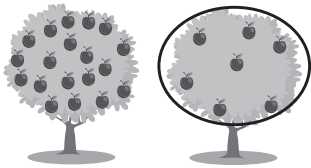
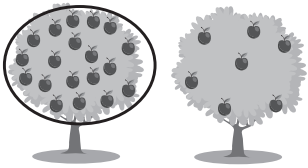
Use with Activities 1 and 2.

Comparing numbers and mystery symbols			
 circle	 false	 left	 less
 more	 right	= % * + & \$ > < symbol	 true



I notice the number on the _____ is ...
(left / right)

The symbol means _____ because ...





Problem 6 is _____ because ...
(true / false)

Word bank		
English	compare	equal
Español	comparar	igual

Name _____ Date _____

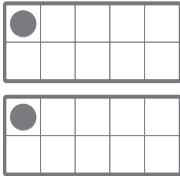
What Digit?

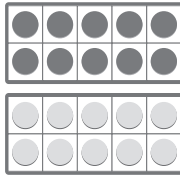
Use with Activity 2.

 left	 ones	 right	$=$ $\%$ $*$ $+$ $\&$ $\$$ $>$ $<$ symbol	 tens	 true
---	---	--	--	---	---

I know it is _____ because . . .

The _____ symbol goes in the open space because . . .

_____ goes in the open space because it . . .

is greater than _____.
is less than _____.
is equal to _____.

Comparison symbols		
$=$ equal	$>$ greater than	$<$ less than

Word bank	
English	Español
comparison	comparación
digit	dígito
equal	igual

Name _____ Date _____

Spin and Compare

Use with Activity 2.

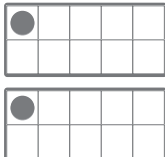
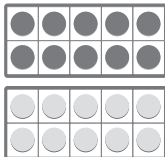
Comparing numbers				
=	>	<		
equal	greater than	less than	ones	tens



Their statement is _____
(true / false)

because . . .

_____ has _____ tens
and _____ ones.

_____ tens is _____
(more / less)
than _____ tens.

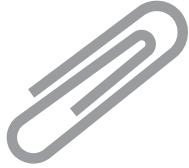
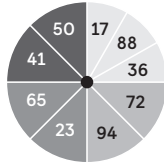
_____ ones is _____
(more / less)
than _____ ones.

Spin!		
		
paper clip	spinner	spins

Word bank	
English	Español
comparison	comparación
digit	dígito
false	falso
true	verdadero

Name _____ Date _____

Card Sort: Collections in Order

Use with Activity 2.

 cards	 coupon	 greatest	 guitar pick
 least	 ones	 snowglobe	 tens

I compare the numbers by ...

_____ is the _____ number.
(number) (greatest / least)

The strategies are _____
(alike / different)

because ...



I _____ and they _____.

Word bank	
English	Español
collection	colección
compare	comparar
digit	dígito
greater than	mayor que
less than	menor que

Name _____ Date _____

How Many Ways?

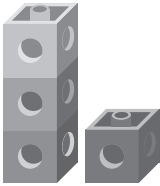
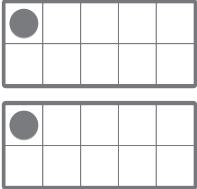
Use with Activity 2.

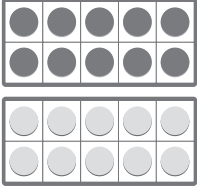
Representations			
Expressions		Cubes	Words
$+$ add	$=$ equal	 cubes	 ones
$4 + 2 = 6$ expression	$-$ subtract	 tower of ten	 tens

I can make 47 using _____ towers of 10 and _____ cubes.

I can also make 47 using _____ towers of 10 and _____ cubes.

I know both representations show the same number because . . .

_____ tens and _____ ones is equal to _____.



_____ tens and _____ ones is the same as _____.

Word bank				
English	digit	greater than	less than	representation
Español	dígito	mayor que	menor que	representación

Name _____ Date _____

How Many in the Collection?

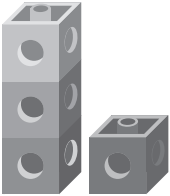
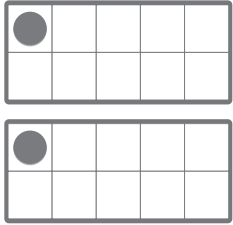
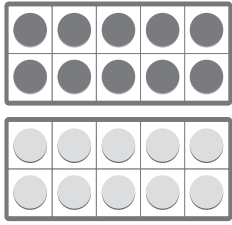
Use with Activities 1 and 2.

Representations			
 <p>cubes</p>	 <p>ones</p>	 <p>tens</p>	 <p>tower of ten</p>

I can represent _____ using _____ tens and _____ ones.

A different way of representing _____ is using _____ tens and _____ ones.

These representations show the number _____ because each representation has _____ tens and _____ ones.

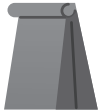
Mystery bags		
<p>+</p> <p>add</p>	 <p>bag</p>	<p>—</p> <p>subtract</p>

Word bank			
English	greater than	less than	representation
Español	mayor que	menor que	representación

Name _____ Date _____

Getting Ready

Use with Activities 1 and 2.

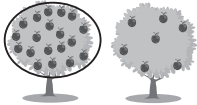
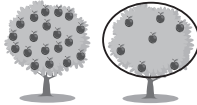
Comparisons					
=		>	<		= % * + & \$ > <
equal	fewer	greater than	less than	more	symbol

I knew _____ had _____ because ...
(*more / fewer*)

I chose _____ because ...
(*greater than / less than / equal to*)

Collections		
 books	 bookmark	 cards
 friendship bracelet	 rocks	 shell
 snow globe	 stamp	 stickers

Word bank	
English	Español
compare	comparar
digit	dígito
equal	igual
ones	unidades
tens	decenas
true	verdadero

Name _____ Date _____

Ways to be a Mathematician

Formas de ser matemático/ matemática

- 1** I can take my time to think about a challenging problem before trying to solve it.

Puedo tomarme mi tiempo para pensar en un problema difícil antes de intentar resolverlo.



- 2** I can use numbers, words, and diagrams to make sense of math ideas and situations.

Puedo usar números, palabras y diagramas para entender ideas y situaciones matemáticas.

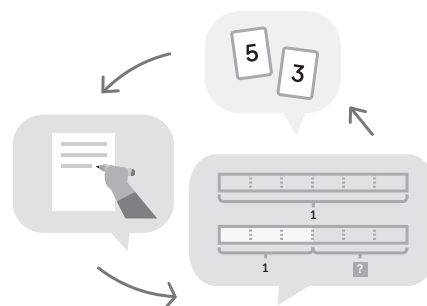

- 3** I can see how ideas are connected and use patterns to help solve problems.

Puedo ver cómo se conectan las ideas y utilizar patrones para resolver problemas.



Name _____ Date _____

Questions and Sentence Frames

Why did you choose this statement?

Did you choose any others? Why or why not?

How did you use this thinking during the Activity?

Can you tell me more?

I chose this statement because . . .







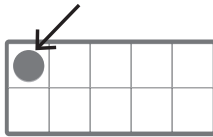
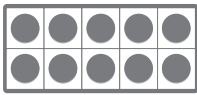

I also chose _____ because . . .

In the Activity, I . . .

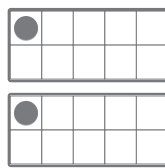
Name _____ Date _____

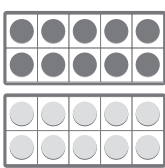
Loading the Truck

Use with Activities 1 and 2.

Loading the wazzle-squashes				
 a one	 a ten	$+$ add	 festival	 ones
 park	 tens	 townsfolk	 truck	 wazzle-squash

I found the answer by . . .

I knew I needed to add _____ because . . .
(*tens/ones*)

When I add _____ to a two-digit number . . .
(*tens/ones*)

but . . .

and . . .





this is different because . . .

Word bank					
English	change	different	digit	equation	true
Español	cambiar	diferente	dígito	ecuación	verdadero

Name _____ Date _____

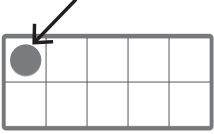
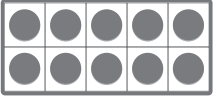
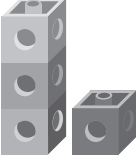
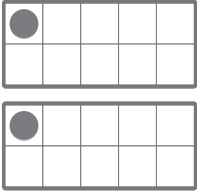
Gallery Tour: Finding Sums

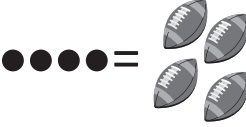
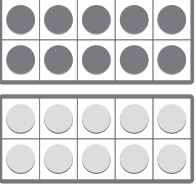
Use with Activity 2.

Asking questions				
 a one	 a ten	$+$ add	 cubes	$2 + 7 = 9$ equation
 ones	 question	 represent	 tens	 tower of ten

I think ...

they ...

it means ...

because ...

The _____ comes from ...
(number)











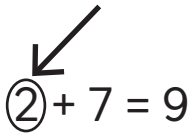

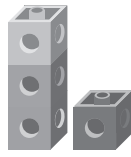
Word bank	
English	Español
both	ambos
different	diferente
digit	dígito
same	mismo
strategy	estrategia

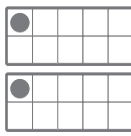
Question words						
English	how?	what?	when?	where?	who?	why?
Español	¿cómo?	¿qué?	¿cuándo?	¿dónde?	¿quién?	¿por qué?

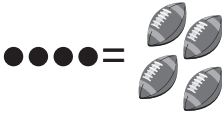
Name _____ Date _____

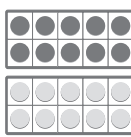
How Many Pots?

Use with Activities 1 and 2.



Making wazzle-squash butter			
 add	 $2 + 7 = 9$ addend	 bakery	 butter
 cubes	$2 + 7 = 9$ equation	 family	 jar
 ones	 pot	 represent	 restaurant
 tens	 tower of ten	 underline	 wazzle-squash

1. First, _____ ...
(we/I think)
2. Next, _____ ...
(we/I think)
3. Then _____ ...
(we/I think)
because ...
and the total was ...

Name _____ Date _____

How Many Wazzle-Squashes?

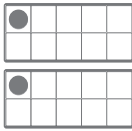
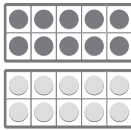
Use with Activities 1 and 2.

How many wazzle-squashes?				
	$2 + 7 = 9$			
bucket	equation	ones	tens	wazzle-squash

I could add ...

Next, I ...



Then I ...

Together that makes ...

I made a new ten in Problem 2/3 ...

because ...

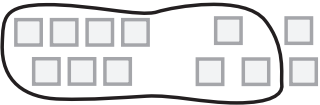
Word bank	
English	Español
add	sumar
digit	dígito
true	verdadero



Definition	Characteristics
<p>Combining ones to make a sum of ten</p> <p>$7 + 5 = 12$</p> 	<p>more ones than tens addition</p> <p>$6 + 3 = 9$</p> 
<p>Example</p>	<p>Non-Example</p>

making a new ten
hacer una nueva decena

Name _____ Date _____

Cubes on the Mat

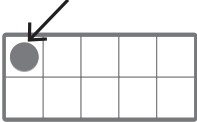
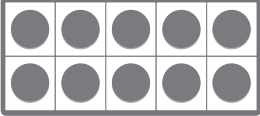
Use with Activities 1 and 2.

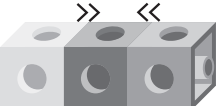
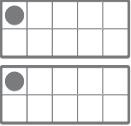
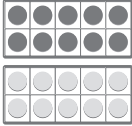
 <p>a one</p>	 <p>a ten</p>	<p>+</p> <p>add</p>	 <p>break apart</p>
 <p>connect</p>	 <p>ones</p>	<p>$2 + 7 = 9$</p> <p>sum</p>	 <p>tens</p>

I solved the problem by ...

Next, I ...

Then I ...

The answer is ...

I noticed there was/were ...

I _____ make a new ten.
(*did/did not*)

Word bank	
English	Español
digit	dígito
expression	expresión







I need to circle the thumb up / thumb down.

Name _____ Date _____

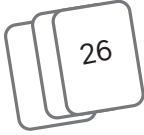
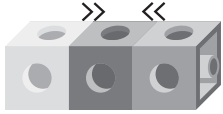
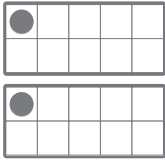
The Next Ten

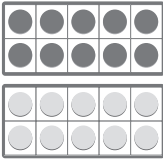
Use with Activities 1 and 2.

Making 10				
<p>+</p> <p>add plus</p>	 <p>break apart</p>	 <p>cards</p>	 <p>connect</p>	
<p>=</p> <p>equal</p>	 <p>ones</p>	 <p>skip count</p>	 <p>tens</p>	 <p>tower of ten</p>

To make the next ten I/we need ...
to add ...

_____ more ones ...
(number)

because ...

the next multiple of ten is ...

I found the answer by ...

The next ten is ...





_____ is _____ more ones than _____.
(multiple of 10)

Word bank	
English	Español
digit	dígito

Name _____ Date _____

Planning a Delivery Route

Use with Activities 1 and 2.

Making deliveries			
 delivery route	 map	 package	 wazzle-squash

We thought about how many . . .

_____ did/did not make
(*number*)





a new ten.

The missing number could
be _____ because . . .

it could also be . . .

another number is . . .

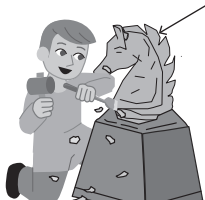
Word bank	
English	Español
digit	dígito
equal	igual
expression	expresión
ones	unidades
plus	más
sum	suma
tens	decenas

How many sculptures?				
 artist	 festival	 rain	 sculpture	 smudge

Name _____ Date _____

Packing it Up

Use with Activity 2.

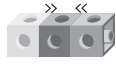
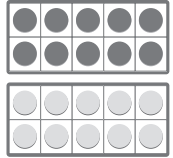
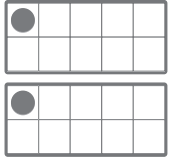
Strategies					
adding by place value		counting cubes		Tens and Ones Mat	
24 ↑	24 ↑				
ones	tens	break apart	connect	tens	ones



I _____ make a new ten . . .
(*did/did not*)

_____ is _____ than 10.
(*number*) (*more/less*)

The strategy I used was . . .

1. First, I . . .
2. Next, I . . .
3. Then I . . .



Word bank	
English	Español
different	diferente
digit	dígito
equal	igual
less	menos
more	más
same	mismo
sum	suma
total	total

Baking crisps	
	
baker	wazzle-squash

Name _____ Date _____

Thinking About Tens

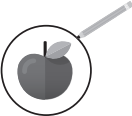
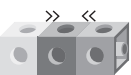
Use with Activity 2.

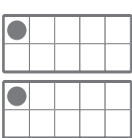
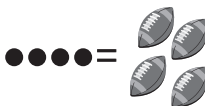
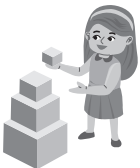
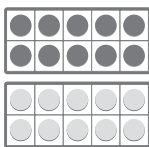
Thinking about tens				
 break apart	 circle	 connect	 draw	$2 + 7 = 9$ equation
 invitation	 ones	 represent	 stack	 tens



Explaining your work	
I found the sum by ...	I found the number of tens by ...
1. first _____ ... <i>(adding/circling/drawing/making)</i>	
2. Next, I _____ ... <i>(added/circled/drew/made)</i>	
3. Then I _____ ... <i>(added/circled/drew/made)</i>	
Which is ...	The total is ...

Word bank			
English	add	digit	sum
Español	sumar	dígito	suma

Name _____ Date _____

How Many Tens?

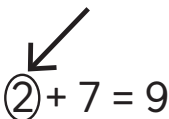
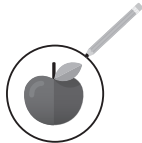
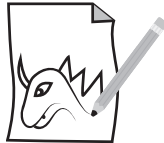
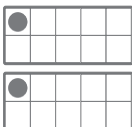
Use with Activities 1 and 2.

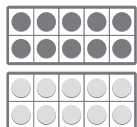
How many tens?			
+	 2 + 7 = 9	 circle	 draw
add	addend	circle	draw
$2 + 7 = 9$	 ones	$2 + 7 = 9$ 	 tens
equation	ones	sum	tens

There will be _____ tens in the sum
because _____ plus _____ ...
makes a new ten ...

I found the sum by ...

1. first _____ ...
(adding/circling/drawing/making)
2. Next, I _____ ...
(added/circled/drew/made)
3. Then I _____ ...
(added/circled/drew/made)

Problem 3 _____ help me with Problem 4 because ...
(did/did not)

I knew the sum ...

I made a new ten ...











It _____ have the same number of _____.
(did/did not) (tens/ones)

Word bank	
English	Español
digit	dígito
expression	expresión
represent	representar

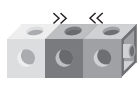
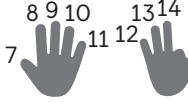
Name _____ Date _____

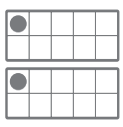
Choosing Strategies

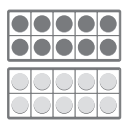
Use with Activity 2.

Counting crisps and addition strategies			
 add	 $2 + 7 = 9$ addend	 bag	 break apart
 circle	 connect	 count on	 draw
 ones	 $2 + 7 = 9$ sum	 tens	 wazzle-squash

I used the strategy of ...

I found the answer by ...

1. first _____ ...

*(adding/circling/
drawing/making)*

2. Next, I _____ ...

*(added/circled/
drew/made)*

3. Then I _____ ...

*(added/circled/
drew/made)*

Yes, I did/No, I did not

use the same strategy ...

because ...

For Problem 4/5, I ...

I made a new ten ...

The total is ...







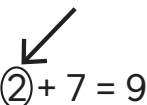

Word bank

English	add	different	digit	same	strategy
Español	sumar	diferente	dígito	mismo	estrategia

Name _____ Date _____

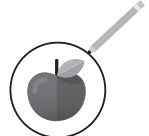
Changing an Addend Tour

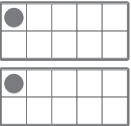
Use with Activity 2.

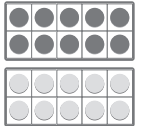
Wazzle-squash toss and addend tour				
 addend	 agree	 ball	 catch	 circle
 disagree	$2 + 7 = 9$ equation	 ones	 poster	 tens

 I notice ...
I see ...

Word bank			
English	add	digit	strategy
Español	sumar	dígito	estrategia

When the _____ changed ...
(number/addend)

I think they changed it to _____ because ...

I _____ because ...
(agree/disagree)

when they ...





they needed to ...

I would have ...

Name _____ Date _____

Questions About Donations

Use with Activities 1 and 2.

Donations of wazzle-squash food				
				
butter	container	crisps	seed	wazzle-squash

How many containers of _____ and _____ are there _____?
(in total/altogether)

What is the total _____ of ...
(number/amount)

I chose _____ to be my question.

I found the answer by ...

1. First, ...
2. Next, ...
3. Then, ...

The total is ...

Word bank	
English	Español
category	categoría
data	datos
digit	dígito
equation	ecuación
ones	unidades
represent	representar
sum	suma
tens	decenas
underline	subrayar

Question words						
English	how?	what?	when?	where?	who?	why?
Español	¿cómo?	¿qué?	¿cuándo?	¿dónde?	¿quién?	¿por qué?

Vocabulary Cards, Unit 6

✂ - **Directions:** Make enough copies so that each student receives one card for each term. Pre-cut the cards and distribute them during Lesson 2.

height

The measure of how tall an object is from endpoint to endpoint.



Vocabulary Cards, Unit 6 · Lesson 2

length

The measure of how long an object is from endpoint to endpoint.



Vocabulary Cards, Unit 6 · Lesson 2

height

The measure of how tall an object is from endpoint to endpoint.



Vocabulary Cards, Unit 6 · Lesson 2

length

The measure of how long an object is from endpoint to endpoint.



Vocabulary Cards, Unit 6 · Lesson 2

height

The measure of how tall an object is from endpoint to endpoint.



Vocabulary Cards, Unit 6 · Lesson 2

length

The measure of how long an object is from endpoint to endpoint.

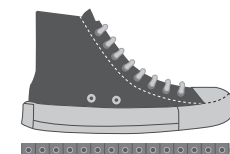

Vocabulary Cards, Unit 6 · Lesson 2

height

The measure of how tall an object is from endpoint to endpoint.



Vocabulary Cards, Unit 6 · Lesson 2

length

The measure of how long an object is from endpoint to endpoint.

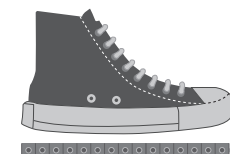

Vocabulary Cards, Unit 6 · Lesson 2

Name _____ Date _____

Ways to be a Mathematician

Formas de ser matemático/ matemática

- 1** I can take my time to think about a challenging problem before trying to solve it.

Puedo tomarme mi tiempo para pensar en un problema difícil antes de intentar resolverlo.



- 2** I can explain why my thinking makes sense and ask questions to understand the thinking of others.

Puedo explicar por qué mi razonamiento hace sentido y hacer preguntas para comprender el razonamiento de los demás.

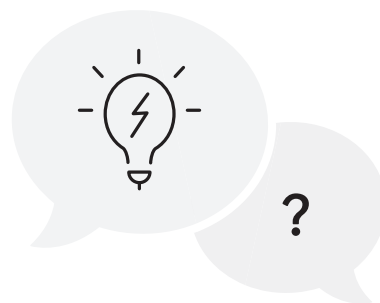

- 3** I can work carefully and try to be clear when I share my ideas.

Puedo trabajar con cuidado y tratar de ser claro/clara cuando comparto mis ideas.

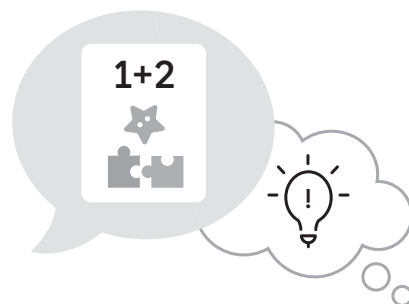

Name _____ Date _____

Questions and Sentence Frames

Why did you choose this statement?

Did you choose any others? Why or why not?

How did you use this thinking during the Activity?

Can you tell me more?

I chose this statement because . . .



I also chose _____ because . . .

In the Activity, I . . .

Name _____ Date _____

Getting Things in Order

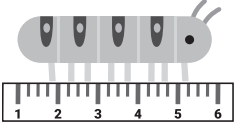
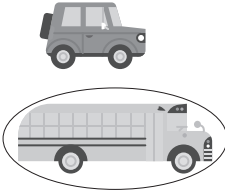
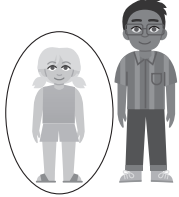
Use with Activities 1 and 2.

Measuring				
				
height	length	longer	shortest	tallest

When something is the tallest/shortest . . .

The _____ is the tallest.









The _____ is the shortest.

The _____ is in the middle.

Word bank	
English	Español
compare	comparar









I can use the crayon to . . .

Outdoor objects			
			
bird	clover	feather	flower
			
mushroom	pine cone	stick	worm

Name _____ Date _____

Which Shoe Print Is Longer?

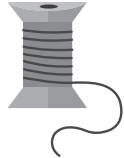
Use with Activity 2.

Measuring shoe prints					
					
cut	heel	scissors	shoe print	string	toe

Shoe print S/T is longer because . . .

Shoe print S/T is . . .



longer than the string.

shorter than the string.

the same length as the string.

Word bank	
English	Español
compare	comparar
different	diferente
same	mismo

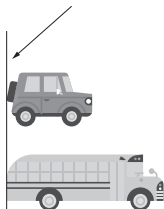
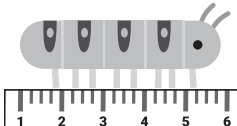
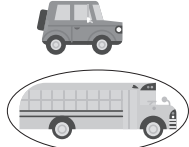
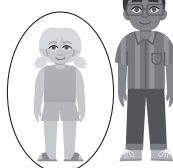

My partner and I . . .

Measuring				
				
endpoint	length	longer	shorter	taller

Name _____ Date _____

Vehicle Book

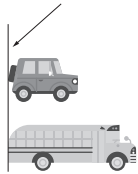
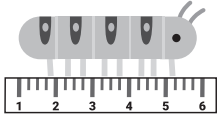
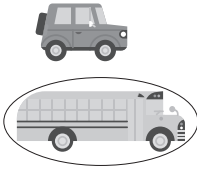
Use with Activities 1 and 2.

Measuring				
				
endpoint	length	longer	shorter	taller

The _____ is the same length as a tower of _____ cubes.



I know it's true because . . .

I measured . . .

I lined up . . .

the cubes start/end . . .

The length of the _____ is _____ connecting cubes.

Measuring	
	
cubes	tower

Word bank	
English	Español
compare	comparar
different	diferente
same	mismo
true	verdadero

Name _____ Date _____

Picnic Basket

Use with Activities 1 and 2.

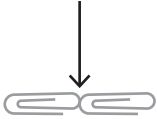
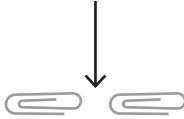
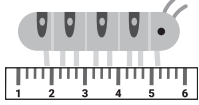
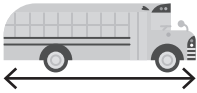
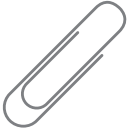
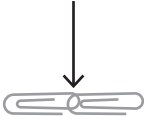
Measuring picnic baskets		
 end to end	 gap	 length
 long	 paper clip	 overlap



I think measurement A/B/C is correct because ...



I think measurement A/B/C is incorrect because ...





I know my measurement is correct because ...

Name _____ Date _____

Wristbands

Use with Activity 2.

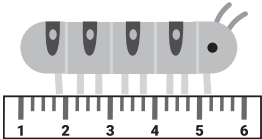
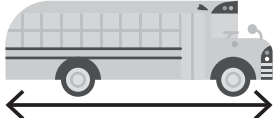
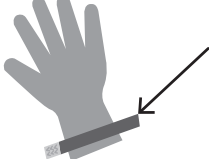
 adult	 child	 height
 length	 long	 wristband



I agree with Trevor because . . .











I disagree with Trevor because . . .

Word bank	
English	Español
different	diferente
same	mismo

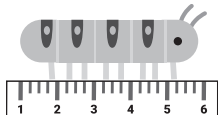
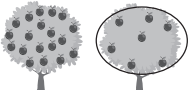
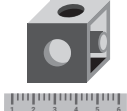
Name _____ Date _____

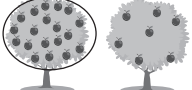
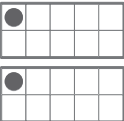
Long Length, Short Units

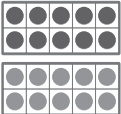
Use with Activities 1 and 2.

Measuring wingspans			
 bird	 bird sanctuary	 black skimmer	 length
 less	 length unit	 longer	 more
 ones	 shorter	 tens	 wingspan

Measuring a longer length and a shorter length is _____ because _____.

First, we ...







Then we ...

Word bank	
English	Español
count	contar
different	diferente
digit	dígito
same	mismo

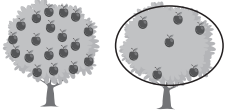
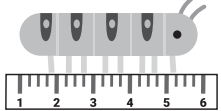
Name _____ Date _____

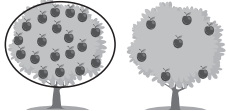
Using a New Tool

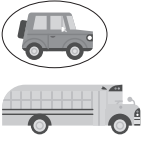
Use with Activities 1 and 2.

Measuring more wingspans			
 fewer	 length	 longer	 more
 scavenger hunt	 shorter	 tools	 wingspan

I estimate there
are _____ unit cubes.

The bird's wingspan
is _____ unit cubes.

I measured it with

_____ rods.

_____ cubes.

Word bank	
English	Español
cubes	cubos
different	diferente
digit	dígito
estimate	estimar
one	unidad
rods	barras
same	mismo
ten	decena

They are the same/different because . . .







Name _____ Date _____



Finding the Secret Heights

Use with Activity 2.

The bird is _____ unit cubes tall.

 I notice ...
I also notice ...
that all of the numbers ...

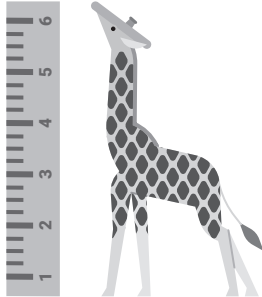
Secret birds	
	
black vulture	giant ibis
	
greater flamingo	secretary bird
	
shoebill stork	southern cassowary

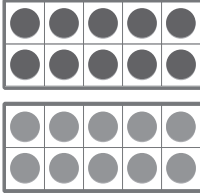
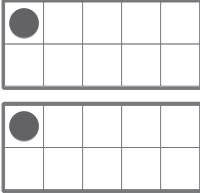





Measuring secret bird heights	
	
height	tall
	
tens	ones

Word bank	
English	Español
digit	dígito
number	número
one	unidad
representation	representación
ten	decena

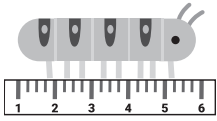
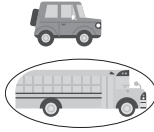
Name _____ Date _____

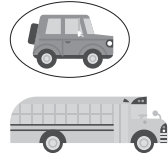

Changing Shadows

Use with Activity 2.

Measuring shadows			
			
length	longer	milkweed	nest
			
question	shadow	shorter	taller

How much _____ is the shadow at _____ than at _____?
(longer/shorter)

I made a tower of _____ cubes



Time of day		
		
breakfast	lunch	dinner

Word bank	
English	Español
compare	comparar
data	datos
difference	diferencia
equation	ecuación
represent	representar
sum	suma

Name _____ Date _____

Animal Footprints

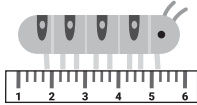

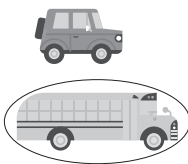
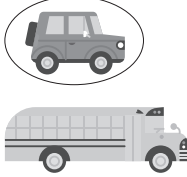



Use with Activities 1 and 2.

Measuring footprints				
				
footprint	length	long	longer	shorter

How long is the _____?

How much _____ is the _____ than the _____?
(longer/shorter)

The representation matches because . . .



Animals		
		
alligator	emu	giraffe
		
hippo	kangaroo	lion

Word bank	
English	Español
difference	diferencia
equation	ecuación
question	pregunta
represent	representar
sum	suma

Name _____ Date _____

Sean's Blocks

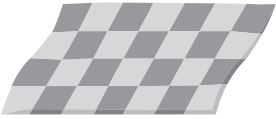
Use with Activities 1 and 2.

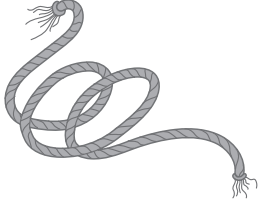
Sean and Trevor share			
			
blanket	blocks	branch	rope

_____, it _____ show the known
(Yes/No) (does/does not)

and unknown amounts because . . .

there are _____ dark squares.

there are _____ light squares.

altogether, there are . . .

It's _____ because . . .
(the same/different)







Word bank	
English	Español
add	sumar
difference	diferencia
different	diferente
represent	representar
same	mismo
subtract	sustraer
sum	suma

 I noticed I could . . .

Name _____ Date _____

Trevor's Story Problems

Use with Activities 1 and 2.

Trevor's story problems		
 bird	 flew	 flower
 jump	 squirrel	 tree

I can use _____ because ...
(addition/subtraction)

It can be solved with _____ because ...
(addition/subtraction/both)

I can also ...

both are ...

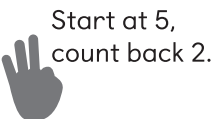
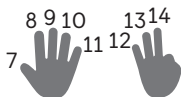
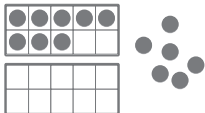

Word bank	
English	Español
add	sumar
both	ambos
difference	diferencia
different	diferente
represent	representar
subtract	sustraer

Addition and subtraction strategies		
 count back	 count on	 take away

Name _____ Date _____

Playing a Card Game

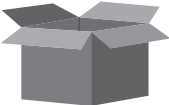
Use with Activities 1 and 2.

Playing card games		
$+$ add	 box	 cards
$3 + 4 = 7$ equation	 mom	$-$ subtract

I know ...



I don't know ...

I need to find out ...

I can find the unknown
_____ by ...
(*amount/number*)

I can represent the equation ...

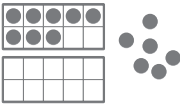

Word bank	
English	Español
both	ambos
difference	diferencia
point	punto
represent	representar
round	ronda
sum	suma
total	total
true	verdadero

Addition and subtraction strategies		
 Start at 5, count back 2. count back	 count on	 take away

Name _____ Date _____

Questions About Math Centers

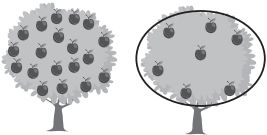
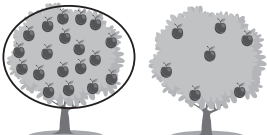
Use with Activities 1 and 2.

Math center rounds		
 fewer	 more	 question

How many _____ rounds did they play of _____ than _____ ?
(*more/fewer*)







How many total rounds _____ ?

Did they ...

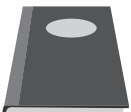
How many ...

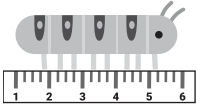
I chose ...

I can represent it by/with ...

Missing measurements		
 book	 computer screen	 length
 longer	 pencil	 shorter

Word bank	
English	Español
data	datos
difference	diferencia
equation	ecuación
represent	representar
round	ronda
sum	suma
total	total

Vocabulary Cards, Unit 7

 **Directions:** Make enough copies so that each student receives one card for each term. Pre-cut the cards and distribute them during the lesson(s) in which the term is introduced.

attribute

A feature or trait that describes an object or set of objects.

Vocabulary Cards, Unit 7 · Lesson 3

a fourth / fourths

Each part of a shape that is split into 4 equal parts.



Vocabulary Cards, Unit 7 · Lesson 8

a half / halves

Each part of a shape that is split into 2 equal parts.



Vocabulary Cards, Unit 7 · Lesson 9

half past

An expression that means it is 30 minutes past the hour.

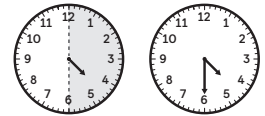

Vocabulary Cards, Unit 7 · Lesson 13

hour hand

The short arrow on a clock that points to the hour.

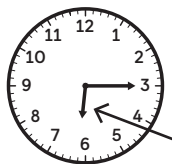

Vocabulary Cards, Unit 7 · Lesson 12

minute hand

The long line on a clock that shows the number of minutes.

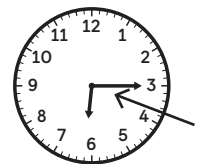

Vocabulary Cards, Unit 7 · Lesson 15

rectangular prism

A solid shape with 6 faces that are all rectangles.

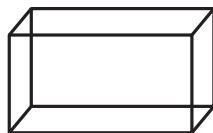

Vocabulary Cards, Unit 7 · Lesson 2

square corner

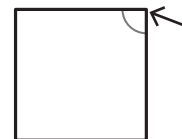

Vocabulary Cards, Unit 7 · Lesson 4

Vocabulary Cards, Unit 7

(Continued)

triangular prism

A solid shape with 2 triangular faces and 3 rectangular faces.

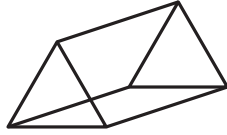

Vocabulary Cards, Unit 7 · Lesson 2

Name _____ Date _____

Ways to be a Mathematician

Formas de ser matemático/ matemática

- 1** I can take my time to think about a challenging problem before trying to solve it.

Puedo tomarme mi tiempo para pensar en un problema difícil antes de intentar resolverlo.



- 2** I can explain why my thinking makes sense and ask questions to understand the thinking of others.

Puedo explicar por qué mi razonamiento tiene sentido y hacer preguntas para comprender el razonamiento de los demás.



- 3** I can see how ideas are connected and use patterns to help solve problems.

Puedo ver cómo se conectan las ideas y utilizar patrones para resolver problemas.

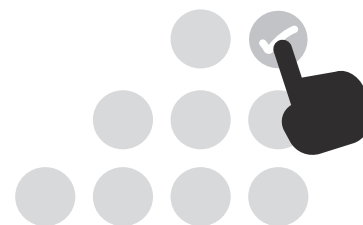

Name _____ Date _____

Questions and Sentence Frames

Why did you choose this statement?

Did you choose any others? Why or why not?

How did you use this thinking during the Activity?

Can you tell me more?

I chose this statement because . . .



I also chose _____ because . . .

In the Activity, I . . .

Name _____ Date _____

Building Rectangular Prisms

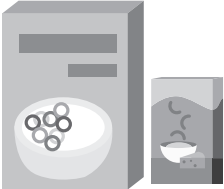
Use with Activity 2.

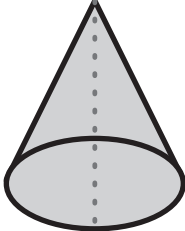
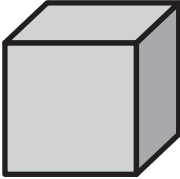
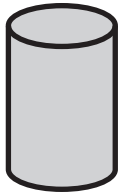
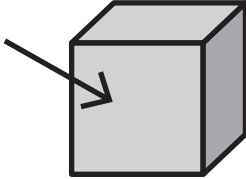
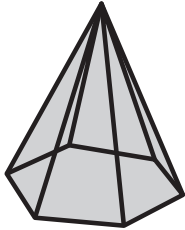
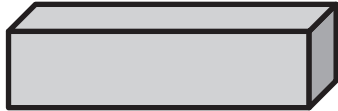
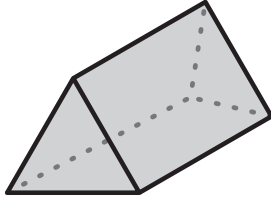
Building with solid shapes			
			
boxes	can	castle	cone
			
cube	cylinder	face	prism
			
rectangular prism		triangular prism	

I could build a rectangular prism using . . .







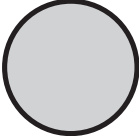
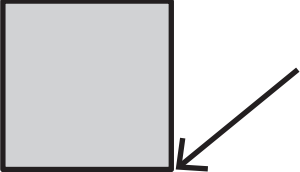

They built their rectangular prism(s) with . . .

Word bank					
English	build	describe	pair	rectangle	triangle
Español	construir	describir	pareja	rectángulo	triángulo

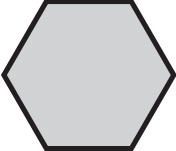
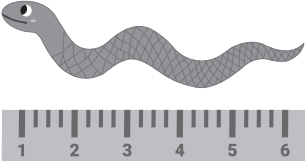
Name _____ Date _____

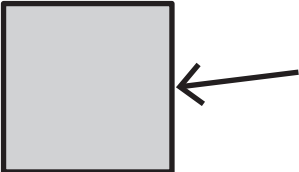
In The Spotlight!

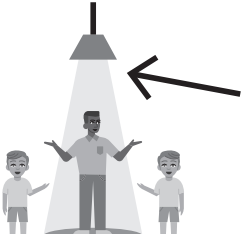
Use with Activities 1 and 2.

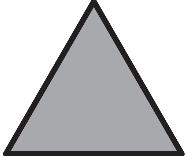
Describing spotlight shapes			
 circle	 corner	 curved	 hexagon
 length	 rectangle	 side	 sort
 spotlight	 square	 straight	 triangle

I chose the _____ as my spotlight shape.

_____ can go with the _____.

All the shapes have/do not have . . .

This shape has/does not have . . .



_____ sides/corners.

Word bank	
English	Español
attribute	atributo
flat	plano
same	mismo
shape	figura

Name _____ Date _____

All Triangles, All Rectangles

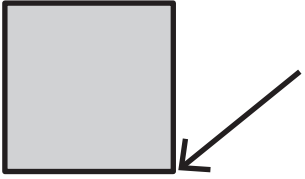
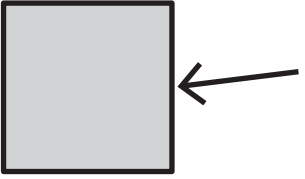
Use with Activities 1 and 2.

Describing flat shapes			
			
corner	side	straight	square



All of our triangles have . . .

_____ corners

and _____ sides.



All of our rectangles have . . .

_____ corners

and _____ sides.



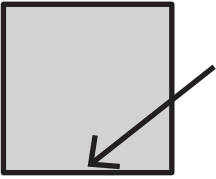
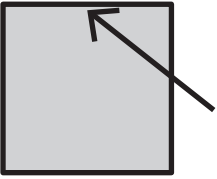



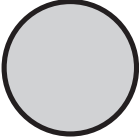
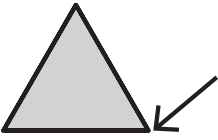

Word bank	
English	Español
always	siempre
attribute	atributo
describe	describir
never	nunca
sometimes	a veces

Pia's statements	
	
bottom	top

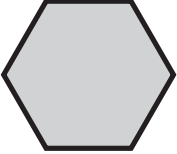
Name _____ Date _____

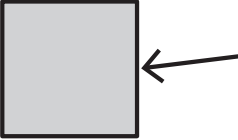
Mix and Mingle: Triangles

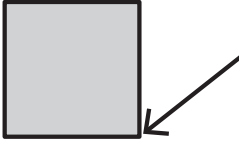
Use with Activities 1 and 2.

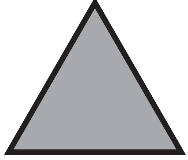
Describing flat shapes				
 circle	 corner	 curved	 hexagon	 rectangle
 side	 square	 square corner	 straight	 triangle

Do you think it is a triangle?

I think it is a triangle because . . .

I don't think it is a triangle because . . .

I think it is a _____ because . . .

Word bank	
English	Español
attribute	atributo
describe	describir
flat	plano
shape	figura

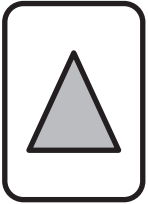
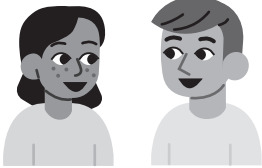
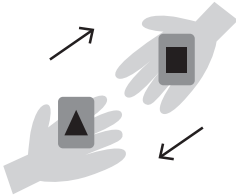
Mix and mingle		
 card	 partner	 trade

Name _____ Date _____

What Shapes Will Rex Eat?

Use with Activities 1 and 2.



I notice Rex can eat ...



A rectangle has ...

_____ sides

_____ corners

Rex can eat all of the shapes because ...



I notice Squish can eat ...



A square has ...

_____ sides

_____ corners

Squish can only eat some of the shapes because ...







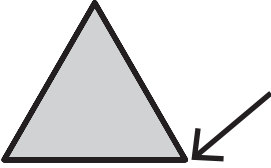
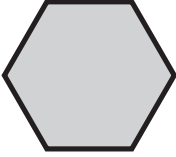
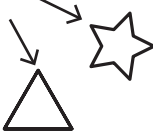

Eating shapes		
 corner	 eat	 length
 side	 square corner	 straight

Word bank	
English	Español
attribute	atributo
both	ambos
cousin	primo/a
different	diferente
same	mismo

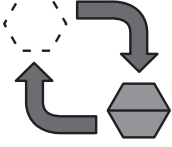
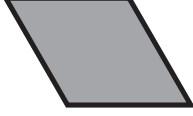
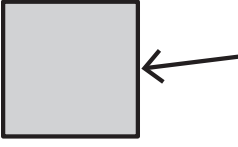
Name _____ Date _____

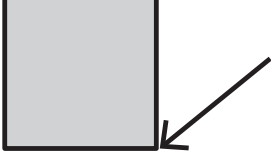
Transforming Triangles

Use with Activities 1 and 2.

Building with shapes			
 corner	 hexagon	 pointy	 rectangle
 replace	 rhombus	 side	 square
 square corner	 straight	 trapezoid	 triangle

I see a _____ in the new shape.





The _____ is/are made out of _____.

Word bank					
English	attribute	describe	design	flat	shape
Español	atributo	describir	diseño	plano	figura
English	red	orange	yellow	green	blue
Español	rojo	naranja	amarillo	verde	azul

Name _____ Date _____

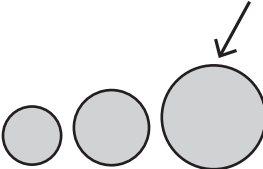
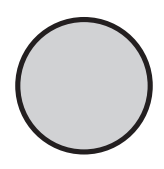
4 Equal Parts

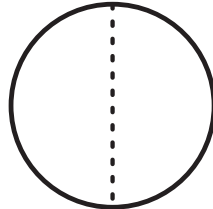
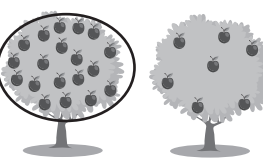
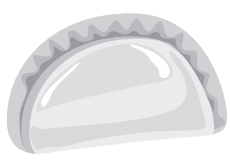
Use with Activity 2.

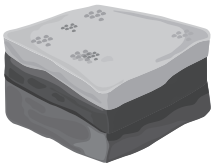
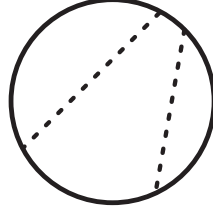
Dinner with Pia and Magda				
 bigger	 circle	 cut slice	 dinner	 equal
 more	 pierogi	 smaller	 tiramisu	 unequal

It is important because ...

It is an example of _____ because ...





I know the parts are equal because ...
when I ...
they are ...

Word bank						
English	dessert	fair	fourth	part	same	size
Español	postre	justo	cuarto	parte	mismo	tamaño

Name _____ Date _____

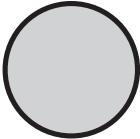
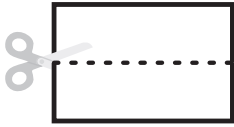
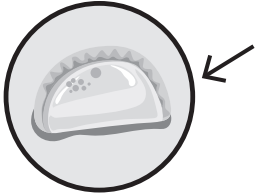
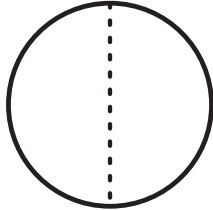
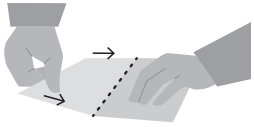
Folding Pierogi Dough

Use with Activity 2.

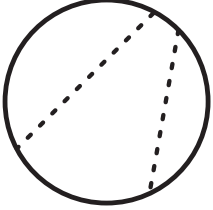
Making pierogies				
				
circle	cut	edge	equal	fold
				
half	pierogi	rectangle	square	unequal

I know the parts are split into halves because . . .

they both are . . .

if I fold/cut it . . .

they line up . . .



_____ the same/even . . .

Word bank						
English	dough	filling	fourth	represent	seal	shape
Español	masa	relleno	cuarto	representar	sellar	figura

Name _____ Date _____

Fair Shares

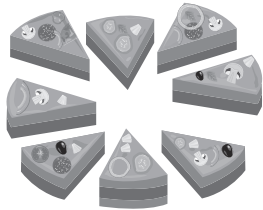
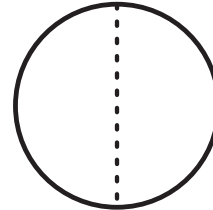
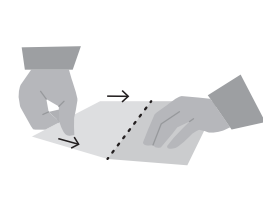
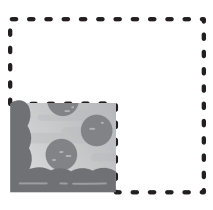
Use with Activity 1.

Sharing fair					
					
cut	slice	equal	fold	fourth	half

I made fourths/halves by ...

I _____ it _____ into _____ equal parts.
(cut/sliced/split) (diagonally/horizontally/vertically)

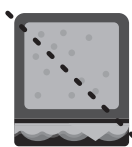
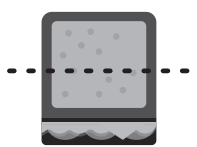
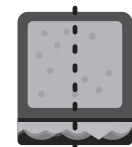
			
diagonally	diagonally	horizontally	vertically

Pia should serve the food cut in _____ because ...
(fourths/halves)







There are _____ equal parts.

Word bank					
English	fair	part	piece	serve	split
Español	justo	parte	trozo	servir	dividir

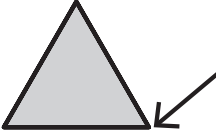
Name _____ Date _____

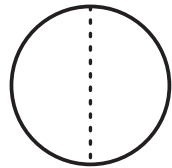
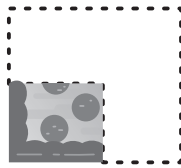
Parts of the Puzzle

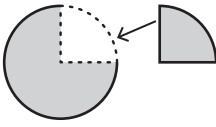
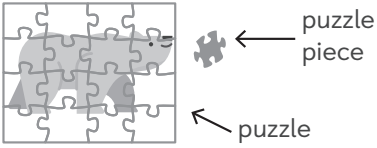
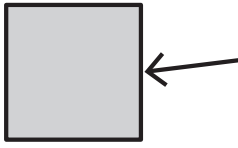
Use with Activity 2.

Parts of the Puzzle					
					
corner	curved	equal	fourth	quarter	half
					
match			side	sort	straight

All the matching parts will . . .

have _____ corners/sides

I/We know all our parts are equal because they all . . .

Our parts made a _____.
(shape)

They are _____
(fourths/halves/quarters)

because . . .

we have . . .

it takes . . .

there are . . .





There are _____.
(2/4) (fourths/halves/parts/quarters)

Word bank	
English	Español
attribute	atributo
describe	describir
line	línea
part	parte
shape	figura
size	tamaño
split	dividir
whole	entero

Name _____ Date _____

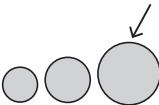
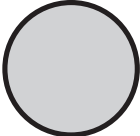
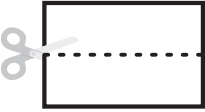
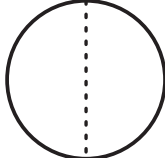
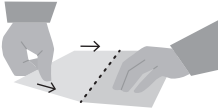
Comparing Halves and Fourths

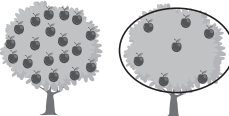
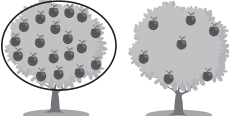
Use with Activities 1 and 2.

Comparing parts					
					
bazlama	bigger	circle	cut	equal	fold
					
fourth	half	less	more	rectangle	smaller

I know they are fourths/halves because ...

They are different because ...

Also, ...



Yes, Ajar made the right choice because ...



No, Ajar didn't make the right choice because ...

Word bank	
English	Español
choice	elección
compare	comparar
different	diferente
part	parte
same	mismo
size	tamaño
whole	entero

Name _____ Date _____

Clocks in Order

Use with Activities 1 and 2.

Analog	Digital
<p>hour hour hand clock face</p>	<p>hour clock face colon</p>

They are alike/the same because ...
They are different because ...

It is _____ o'clock.
I know because ...

I ordered/sorted the cards ...
I decided _____ o'clock went first because ...

Describing clock faces and sorting cards					
card	circle	round	oval	rectangle	sort

Word bank						
English	different	first	hour	order	same	time
Español	diferente	primero	hora	ordenar	mismo	hora

Name _____ Date _____

Half Past What?

Use with Activity 2.

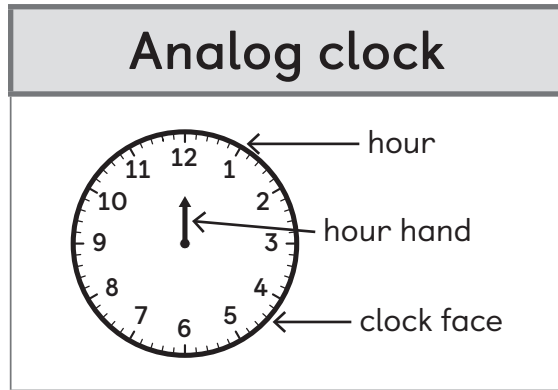

Counting tally marks	
	
1	5

The clocks show . . .

_____ o'clock.

half past _____ o'clock.

_____ people arrived at _____ o'clock.



Yes, Pia is correct because . . .



No, Pia is not correct because . . .

_____ people arrived at _____ o'clock
after 11 o'clock.





in total there were _____ people.

Word bank	
English	Español
arrive	llegar
diagonal	diagonal
group	grupo
half	mitad
half past	y media
people	personas
time	hora
total	total

Name _____ Date _____

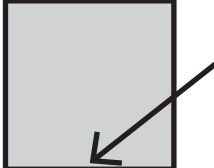
Pia's Favorite Activities

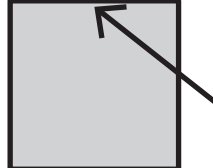
Use with Activity 2.

O'clock or half past?				
				
bottom	down	straight	top	up

I noticed ...

the clock on the top/bottom ...
the minute/hour hand ...

I drew the missing _____ hand ...
(hour/minute)

pointed ...
in between ...

I knew it was ...

_____ o'clock

half past _____
because the hand was ...

Word bank	
English	Español
half	mitad
half past	y media
match	emparejar
missing	faltante
shade	sombrear

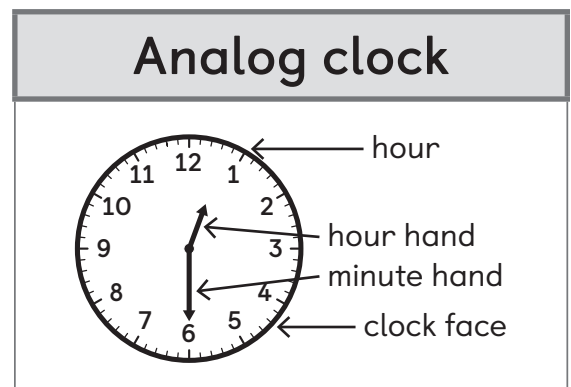

Name _____ Date _____

Pia's Favorite Activities (continued)

Use with Activity 2.

Definition

An expression that means it is 30 minutes past the hour.

Characteristics

The hour hand is halfway between that hour and the next. The minute hand points straight down to 6.

half past
y media

half past 12

12 o'clock

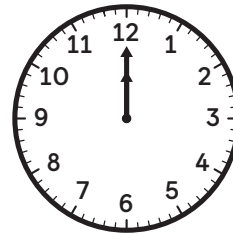
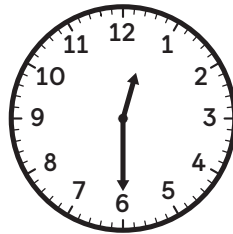

Example

Non-Example

Name _____ Date _____

Counting Minutes

Use with Activities 1 and 2.

Analog	Digital

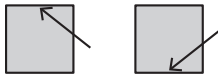

The top/bottom clock shows ...

I think half past 2 is written as 2:30 because ...

each tick mark represents ...

a minute is ...

half past means ...

I think it's ...

_____ o'clock

half past _____

because ...

the minute/hour hand is ...

Word bank	
English	Español
down	abajo
half past	y media
hour	hora
line	línea
minute	minuto
point	marcar
represent	representar
straight	recto
time	hora
up	arriba

Name _____ Date _____

Clock Clues!

Use with Activities 1 and 2.

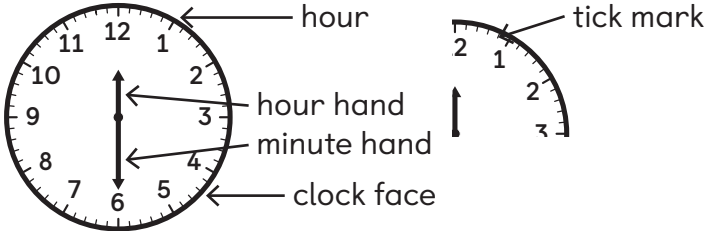
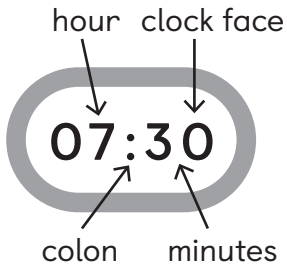
Analog	Digital
 <p>hour</p> <p>hour hand</p> <p>minute hand</p> <p>clock face</p> <p>tick mark</p>	 <p>hour</p> <p>clock face</p> <p>colon</p> <p>minutes</p>

Writing Clues	Interpreting Clues
The time on our clock shows . . .	I/We think it is . . .
<p style="text-align: center;">_____ o'clock</p> <p style="text-align: center;">half past _____.</p>	
Our clues could be . . .	because the clues said . . .
<p style="text-align: center;">The minute/hour hand is pointing _____.</p> <p style="text-align: center;">It is after _____ but before _____.</p> <p style="text-align: center;">It is between _____ and _____.</p>	

Word bank						
English	after	before	between	clues	half past	point
Español	después	antes	entre	pistas	y media	marcar