

 Amplify Desmos Math CALIFORNIA

Grade 3

Volume 2: Units 5–7

Student Edition

About Amplify

Amplify is dedicated to collaborating with educators to create learning experiences that are rigorous and riveting for all students. Amplify creates K–12 core and supplemental curriculum, assessment, and intervention programs for today’s students.

A pioneer in K–12 education since 2000, Amplify is leading the way in next-generation curriculum and assessment. All of our programs provide teachers with powerful tools that help them understand and respond to the needs of every student.

Amplify Desmos Math California is based on curricula from Illustrative Mathematics (IM). IM K–5 is © 2021 Illustrative Mathematics, and is licensed under the Creative Commons Attribution 4.0 International license (CC BY 4.0). Additional modifications contained in Amplify Desmos Math are © 2023 Amplify Education, Inc. and its licensors. Amplify is not affiliated with the Illustrative Mathematics organization.

The *Universal Design for Learning Guidelines* version 2.2 were developed by the Center for Applied Special Technology (CAST). © 2018 CAST.

The “Effective Mathematics Teaching” practices were developed by the National Council of Teachers of Mathematics (NCTM) in *Principles to Actions: Ensuring Mathematical Success for All*. © 2014 NCTM.

Desmos® is a registered trademark of Desmos Studio PBC.

Notice and Wonder® and I Notice/I Wonder™ are trademarks of the National Council of Teachers of Mathematics. Amplify Desmos Math is not sponsored, endorsed by, or affiliated with the National Council of Teachers of Mathematics.

No part of this publication may be reproduced or distributed in any form or by any means without the prior written consent of Amplify Education, Inc., except for the classroom use of the worksheets included for students in some lessons, or as otherwise permitted under the Acceptable Use Policy posted on our website, which is subject to change at any time without notice to you and/or your organization.

Amplify gratefully acknowledges the work of distinguished program advisors from English Learners Success Forum (ELSF), who have been integral in the development of Amplify Desmos Math. ELSF is a 501(c)(3) nonprofit organization whose mission is to expand educational equity for multilingual learners by increasing the supply of high-quality instructional materials that center their cultural and linguistic assets.

Cover illustration by Caroline Hadilaksono.

© 2027 Amplify Education, Inc.
55 Washington Street, Suite 800
Brooklyn, NY 11201
www.amplify.com

ISBN: 9798895800881
Printed in [e.g., the United States of America]
[# of print run] [print vendor] [year of printing]

Hello Curious Mind,

Welcome to Grade 3!

It's a year of many new things in your world and in your math classroom — like multiplication, division, area, and perimeter. You'll also notice that many of the concepts connect to familiar areas of math too!

This year in math, you'll travel the world with Max, using addition and subtraction to help him solve problems with large numbers. You'll meet Harper at the library as you explore equal groups and multiply numbers, and you'll help Cheri — a third grader just like you — use concepts of area to help her family settle into their new home. You'll share ingredients to make dinner for Mr. Gharbi's birthday, and you'll also meet a surprising and helpful friend named Obita as you explore fractions as numbers. You'll even get to help Sasha take measurements as she gets her chicken ready for the fair.

And that's not all!

It's going to be an exciting year! Let's dig in!

Sincerely,

The Amplify Desmos Math California team

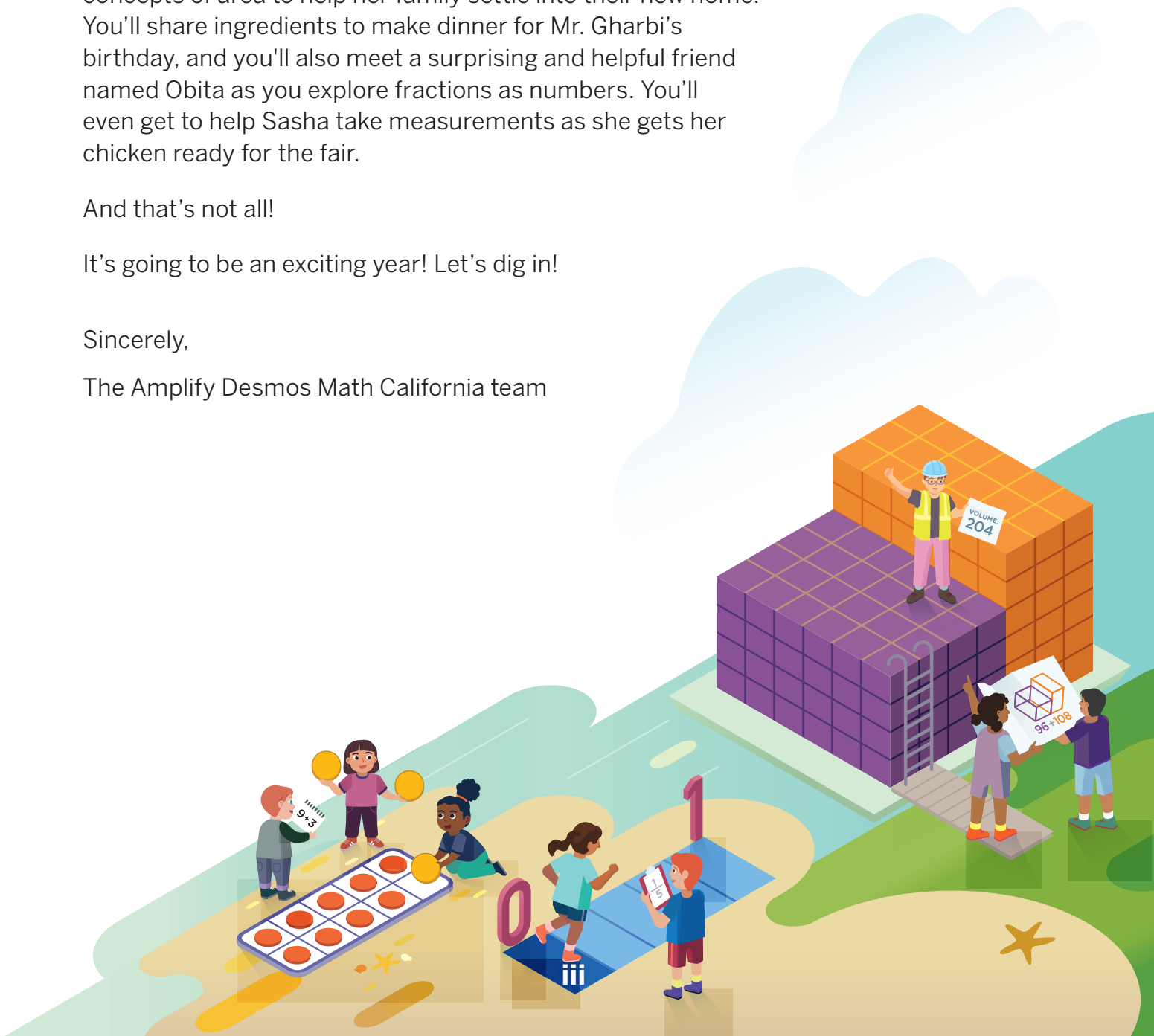

Unit 1 Introducing Multiplication

Let's learn about a new operation and represent data in graphs.

Unit Story: My Name Is Harper In this story, young Harper found her interests and friends at the library. Now she's a grown-up, running that same library.



SvedOliver/Shutterstock.com



Galyna Motizova/Shutterstock.com

Sub-Unit 1 Introduction to Multiplication 3

- 1.01 Explore: Finding Equal Groups 4
- 1.02 Equal Groups 6
- 1.03 More Equal Groups 13
- 1.04 Book Clubs 20
- 1.05 Choosing Your Own Strategy 27
- 1.06 What's Missing? 34
- 1.07 As a Matter of Fact 41



littlenySTOCK/Shutterstock.com

Sub-Unit 2 Arrays 49

- 1.08 Searching for Arrays 50
- 1.09 Arrays of Flavor 57
- 1.10 Organizing Art Supplies 64
- 1.11 A Community Reading Event 71



SvedOliver/Shutterstock.com

Sub-Unit 3 Data in Scaled Graphs 79

- 1.12 Library Surveys 80
- 1.13 School Surveys 84
- 1.14 Which Character Are You? 91
- 1.15 Puppy Pile 96
- 1.16 2, 5, or 10? 102
- 1.17 Raising the Bar 109
- 1.18 Favorite Season 116

Unit 2 Area and Multiplication

Let's measure the space figures take up and relate that to multiplication.

Unit Story: Cheri's New Home In this story, Cheri learns about her new home from the house's previous owner, Ms. Sarah.



Pixel-Shot/Shutterstock.com



pfluegler-photo/Shutterstock.com

Sub-Unit 1 Concepts of Area Measurement	127
2.01 Explore: Comparing Rugs	128
2.02 Which Covers More Space?	130
2.03 Tiling Figures	135
2.04 Area Hunt	141
2.05 Rectangles and Arrays	148



gamespirit/Shutterstock.com

Sub-Unit 2 Relating Area to Multiplication	155
2.06 Rectangular Rugs	156
2.07 Toying With Tiles	163
2.08 Using a Ruler	170
2.09 Painting and Planting With Cheri	175



Ground Picture/Shutterstock.com

Sub-Unit 3 Determining Area of Figures Composed of Rectangles	181
2.10 A Missing Puzzle Piece	182
2.11 Painting Cheri's House	189
2.12 What Do We Need to Know?	196
2.13 Designing a Putting Green	202

Unit 3 Wrapping Up Addition and Subtraction Within 1,000

Let's add and subtract three-digit numbers and decide if our answers make sense.



Resul Muslu/Shutterstock.com

Unit Story: The View From up Here In this story, Max climbs monuments, step by step, to photograph new perspectives.



anutr tosirikul/Shutterstock.com

Sub-Unit 1 Adding Within 1,000	211
3.01 Explore: Creating a Photo Gallery	212
3.02 Panda Patterns	214
3.03 How Would You Solve It?	221
3.04 Adding Your Way	228
3.05 What Is an Algorithm?	235
3.06 Using Fewer Digits	242
3.07 Determining Sums of 2 or More Addends	249
3.08 Adding Strategically	256



Ankshuman Baruah/Shutterstock.com

Sub-Unit 2 Subtracting Within 1,000	263
3.09 Subtracting Your Way	264
3.10 Subtracting With an Algorithm	271
3.11 A New Algorithm	278
3.12 Dynamic Decompositions	285
3.13 Subtracting From Zero?	292
3.14 Subtracting Strategically	299



Kit Leong/Shutterstock.com

Sub-Unit 3 Rounding Within 1,000	307
3.15 Nearest on a Number Line	308
3.16 Close Catch	315
3.17 What's the Goal?	322
3.18 Mystery Numbers	328



Lifestyle Travel Photo/Shutterstock.com

Sub-Unit 4 Solving Two-Step Problems	335
3.19 Does It Make Sense?	336
3.20 Rep-re-sent!	343
3.21 Representing Information	348
3.22 Through the Lens of Numbers	355

Unit 4 Relating Multiplication to Division

Let's explore the relationship between division and multiplication.

*** Unit Story: Home Cooking** In this story, Mateo and Amy prepare a surprise birthday meal for their most loyal customer, Mr. Gharbi.



murattellioglu/Shutterstock.com



Casezy idea/Shutterstock.com

Sub-Unit 1 What Is Division?	365
4.01 Explore: Packing Up Peppers	366
4.02 Representing Division	368
4.03 Family Dinner	375
4.04 Representing and Solving	382



Rawpixel.com/Shutterstock.com

Sub-Unit 2 Relating Multiplication and Division	389
4.05 It's Chili in Here!	390
4.06 Division and Multiplication Equations	397
4.07 Relating Quotients to Familiar Products	402
4.08 Patterns in Multiplication	407



Art4Picture/Shutterstock.com

Sub-Unit 3 Multiplying Greater Numbers	413
4.09 Composing Rectangles	414
4.10 How Do You Split It?	421
4.11 Groups of Groups of 10	427
4.12 Multiplying Teen Numbers	433
4.13 Problems Around the Farm	440
4.14 Multiplying Numbers Greater Than 20	445
4.15 Planting Pepper Seeds	451



dreamstory/Shutterstock.com

Sub-Unit 4 Dividing Greater Numbers	457
4.16 Setting Up the Birthday Party	458
4.17 Looking at the Numbers	464
4.18 Lots and Lots of Groups	471
4.19 Be Flexible!	478
4.20 Peppers and Apples, Oh My!	484

Unit 5 Fractions as Numbers

Let's explore fractions on the number line. Let's compare fractions using area and number line diagrams.



Bob Pool/Shutterstock.com

Unit Story: Coen and Obita In this story, Coen lives alone until an uninvited, tiny guest moves into his home. Eventually the two become friends and use their trade skills to make each other's lives easier.



Kagai19927/Shutterstock.com

Sub-Unit 1 Introduction to Fractions	495
5.01 Explore: Making Parts and Wholes	496
5.02 What Is a Fraction?	498
5.03 One Part Wonder	504
5.04 More Parts, More Wholes	510
5.05 What Parts? How Many Parts?	517



S_Photo/Shutterstock.com

Sub-Unit 2 Fractions on the Number Line	525
5.06 To the Number Line	526
5.07 Fractions on the Number Line	531
5.08 Cat Crossing	537
5.09 Location, Location, Location	544



Artazum/Shutterstock.com

Sub-Unit 3 Equivalent Fractions	551
5.10 Obita's Quilts	552
5.11 Generating Equivalent Fractions	559
5.12 Line-Up	566
5.13 Whole Numbers and Fractions	572
5.14 A New Denominator	579



ppa/Shutterstock.com

Sub-Unit 4 Fraction Comparisons	587
5.15 Seams About Right	588
5.16 Same Number of Parts	593
5.17 Ruby the Red Panda	600

Unit 6 Measuring Length, Time, Liquid Volume, and Weight

Let's work with measurements of length, time, volume, and weight.

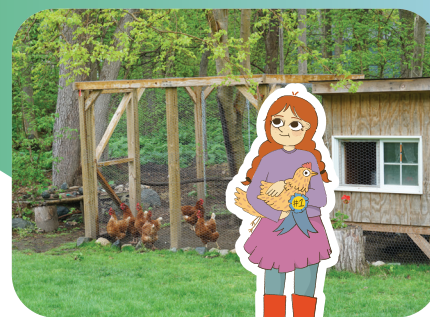

ND700/Shutterstock.com

Unit Story: Just Stick With It, Sasha In this story, Sasha learns about the patience and responsibility needed to raise a show chicken for a county fair competition.

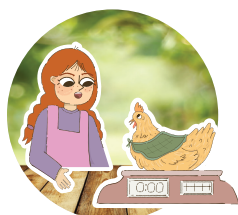

Piotr Krzeslak/Shutterstock.com

Sub-Unit 1 Measurement Data on Line Plots	611
6.01 Explore: Egg-cellent Pick	612
6.02 How Long Is It?	614
6.03 More Precise Measurements	619
6.04 Same Lengths, Different Names	626
6.05 The Plot Chickens	633
6.06 Let's Make a Line Plot	640



Vastram/Shutterstock.com

Sub-Unit 2 Weight and Liquid Volume	645
6.07 Estimating Weight	646
6.08 Weight It Out	653
6.09 Measuring Liquids	660
6.10 How Much Liquid Does It Hold?	667

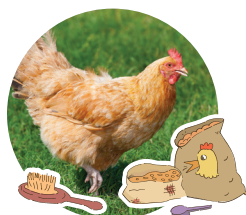

Guy J. Sagi/Shutterstock.com

Sub-Unit 3 Problems Involving Time	675
6.11 Hands of Time	676
6.12 Chicken Time	683
6.13 The Time in Between	690
6.14 All Kinds of Time	697



Gretchen Gunda Enger/Shutterstock.com

Sub-Unit 4 Measurement Problems in Context	703
6.15 Fair Questions	704
6.16 Now Weight	711
6.17 For Good Measure	718

Unit 7 Two-Dimensional Shapes and Perimeter

Let's identify and define attributes of different quadrilaterals.
Let's find the perimeter of two-dimensional shapes.

Unit Story: Through Piho's Eyes In this story, a polar bear named Piho gets the opportunity to see and experience parts of the world from the same perspective as her friend Taka, an Arctic tern.



Christopher Wood/Shutterstock.com



beerlogoff/Shutterstock.com

Sub-Unit 1 Reasoning With Shapes	727
7.01 Explore: Sorting Shapes	728
7.02 Piho's Shapes	730
7.03 Rectangles, Squares, and Rhombuses	737
7.04 More Quadrilaterals	743
7.05 Wax Prints	749



Don Mammoser/Shutterstock.com

Sub-Unit 2 What Is Perimeter?	755
7.06 Distance Around Shapes	756
7.07 Perimeters of Different Shapes	763
7.08 Fencing the Field	770
7.09 Solving Perimeter Problems	777



SKYEX DRONE/Shutterstock.com

Sub-Unit 3 Expanding on Perimeter	785
7.10 In the Real World	786
7.11 Perimeters and Areas	793
7.12 Unique Unicorns	800
7.13 Designing a Tiny House	807

Unit 5

Fractions as Numbers

Big Ideas in This Unit

CC1 Fractions of Shape and Time CC3 Fractions as Relationships
Square Tiles CC4 Unit Fraction Models

Questions for Investigation

- What does a fraction represent?
- How can the same number be represented in multiple ways?
- How do you know whether a fraction is greater than, less than, or equal to another fraction?



Explore: Making Parts and Wholes

What is the relationship between parts and wholes?



Unit Story: Coen and Obita

In this story, Coen lives alone until a tiny tailor moves into his home. Eventually, the two become friends and use their trade skills to make each other's lives easier.

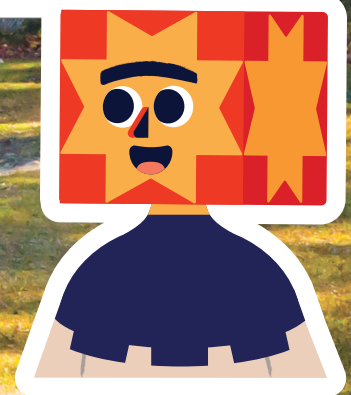

Watch Your Knowledge Grow

This is the math you'll explore in this unit.
Rate your understanding to see how your
knowledge grows!

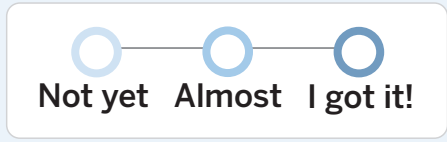

I can . . .	Before	After
Explain how diagrams and fractions represent equal parts of a whole.		
Identify and write unit fractions to describe 1 equal part of a whole.		
Identify and write non-unit fractions that describe more than one equal part of a whole.		
Represent unit and non-unit fractions using diagrams.		
Locate and represent unit and non-unit fractions on a number line diagram.		
Understand two fractions as equivalent if they are the same size, or on the same point on a number line.		
Recognize and generate equivalent fractions using diagrams.		
Express whole numbers as fractions, and recognize fractions that are equivalent to whole numbers.		
Compare two fractions with the same numerator or denominator by reasoning about their size.		

Introduction to Fractions

✦ Unit Story: Coen and Obita



Kagai19927/Shutterstock.com

Sometimes, new people and new ideas can surprise you. When was the last time you were surprised by something you learned in math class?

Explore:

Making Parts and Wholes

What is the relationship between parts and a whole?



Warm-Up



 eyes on teacher



I am a doer of math.

How can you be successful when faced with a challenging problem?

Discuss  What do you notice? What do you wonder?

Coen and Obita

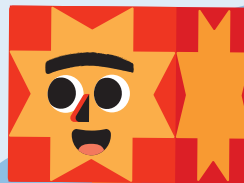

Unit Story



Use your pattern blocks to create as many shapes as you can that match each description. Then create a poster for each description showing the shapes that match that description.

- Description A: Each individual block is a half of the whole shape.
- Description B: Each individual block is a third of the whole shape.
- Description C: Each individual block is a fourth of the whole shape.

Ways to be a mathematician

- 1** I can take my time to think about a challenging problem before trying to solve it.



- 2** I can work carefully and try to be clear when I share my ideas.

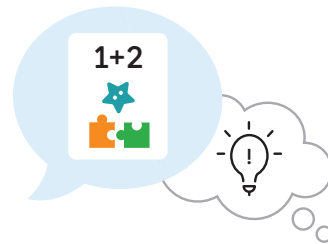

- 3** I can see how ideas are connected and use patterns to help solve problems.

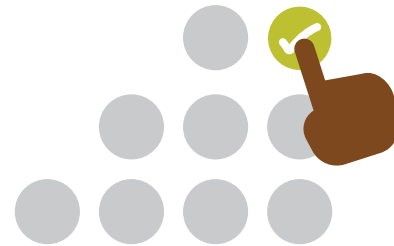

What Is a Fraction?

Let's name equal parts of a whole.



Warm-Up



 eyes on teacher



We are a math community.
What part do you play in our classroom math community?

Activity

1

Folding Paper Strips

Hands-On

You and your partner will be given strips of paper to fold.

- 1 Fold your strips into each type of equal parts.
halves thirds fourths sixths eighths
- 2 Unfold your strips. Draw a line on every fold mark on each strip.
- 3 **Discuss** 
Choose one of your strips and explain how it represents that type of equal parts.

Sharing Art Materials

An art teacher is preparing different materials for his students to use throughout the week.

Draw

- 4 1 strip of ribbon is shared equally with 3 students. Partition the ribbon to show 3 equal parts.



Each equal part is called _____.

How many parts of the ribbon will each student get? _____

- 5 1 hexagon-shaped piece of fabric is split equally for 2 students. Partition the fabric to show 2 equal parts.

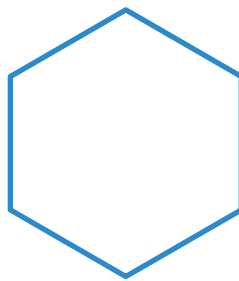

Each equal part is called _____.

How many parts of the fabric will each student get? _____

Sharing Art Materials (continued) **Draw**

- 6 Construction paper is cut into equal pieces for 6 students. Partition the paper to show 6 equal parts.



Each equal part is called _____.

How many parts of the paper will each student get? _____

- 7 4 students will get an equal part of a paper plate. Partition the plate to show 4 equal parts.

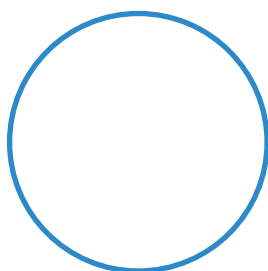

Each equal part is called _____.

How many parts of the paper plate will each student get? _____

Summary 5.02

a sixth/sixths

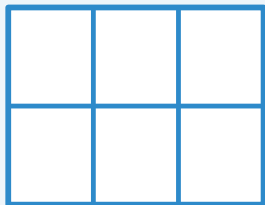

- 6 equal parts
- 6 sixths in the whole
- Each part is one sixth or $\frac{1}{6}$

an eighth/eighths

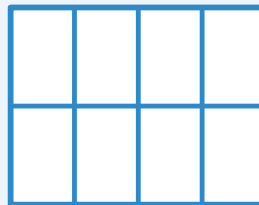

- 8 equal parts
- 8 eighths in the whole
- Each part is one eighth or $\frac{1}{8}$

fraction A number that describes the parts of a whole that has been partitioned into equal parts.

Practice 5.02

For Problems 1–4, the rectangle represents 1 whole. Partition the rectangle into the given type of equal parts.

 Draw

1 fourths



 **Draw**

2 eighths



3 thirds



4 sixths



- 5  Jada split a piece of paper into 3 equal parts. She painted each part a different color. How could you describe the equal parts of her paper?



Spiral Review

For Problems 6–13, determine the value of the expression.

6 7×4 _____

7 2×2 _____

8 5×5 _____

9 8×6 _____

10 4×6 _____

11 10×6 _____

12 9×7 _____

13 8×9 _____

One Part Wonder

Let's explore fractions that describe 1 part of the whole.

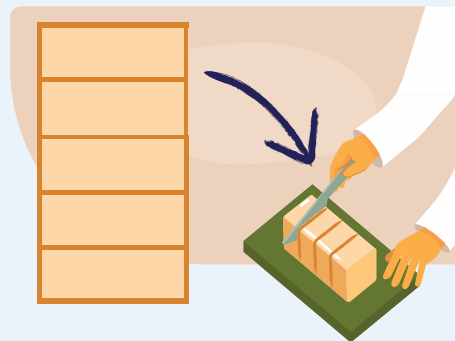

Warm-Up



eyes on teacher



I can be all of me in math class.
What math ideas will you bring to class today?

Activity

1

Partitioning Fraction Strips

- The fraction strip for sixths has already been partitioned, and the value of each part has been named using a fraction.

Partition the other fraction strips to show halves, thirds, fourths, and eighths. Name the value of each part using a fraction.

1 whole

1

halves

1**Partitioning Fraction Strips (continued)**

thirds

--

fourths

--

sixths

$\frac{1}{6}$	$\frac{1}{6}$	$\frac{1}{6}$	$\frac{1}{6}$	$\frac{1}{6}$	$\frac{1}{6}$
---------------	---------------	---------------	---------------	---------------	---------------



eighths

--

2

What's Shaded?

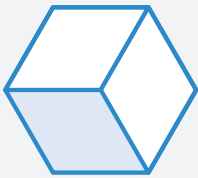
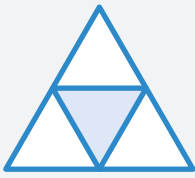
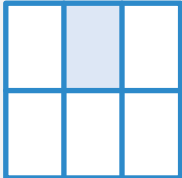
Complete the table to write the fraction of each whole that is shaded.

	Total number of equal parts	Total number of shaded parts	Fraction that is shaded
2 			$\frac{1}{2}$
3 		1	
4 			
5 	6		
6 			

- 7 **Discuss**  Choose one problem from the table. Explain to your partner whether the shaded part of each whole represents a unit fraction or not.

Summary 5.03

Whether you describe each equal part of a whole or 1 equal part that is shaded, you can describe it with a **unit fraction**.

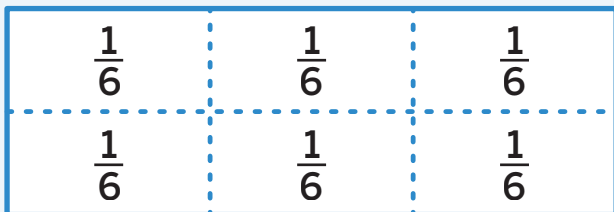

sixths

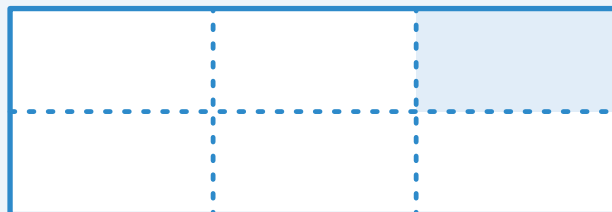

one sixth or $\frac{1}{6}$

unit fraction A fraction that describes exactly 1 part of an equipartitioned shape.

Practice 5.03

- 1 The large rectangle represents 1 whole. What fraction represents the value of each of the equal parts? Explain your thinking.

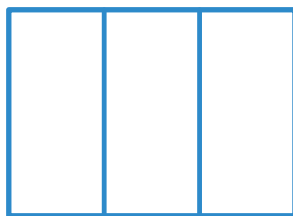

For Problems 2 and 3, the rectangle represents 1 whole. Partition the rectangle into the given number of equal parts. Label the value of each part with a fraction.

 Draw

2 4 equal parts



3 6 equal parts



4  The large rectangle represents 1 whole. Write a fraction that represents the value of the shaded part.

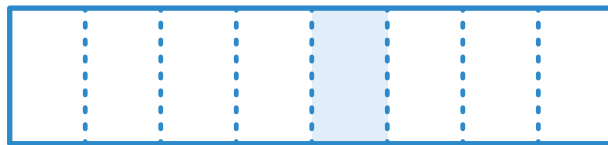

Spiral Review

- 5 For the school's international festival, a teacher arranged 4 rows with 17 chairs in each row. How many chairs did the teacher arrange? Solve the problem and write an expression to represent your work.

answer: _____

expression: _____

For Problems 6–13, determine the value of the expression.

6 3×4 _____

7 2×5 _____

8 7×7 _____

9 6×8 _____

10 4×9 _____

11 10×3 _____

12 8×7 _____

13 2×9 _____

More Parts, More Wholes

Let's explore and name more than 1 part of a whole.

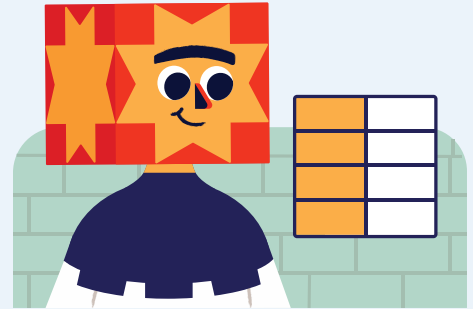

Warm-Up



eyes on teacher



We are a math community.

How can you use math when you need to share 1 thing with a friend?

Activity

1

More Than 1 Part

Each rectangle represents 1 whole French toast stick.

Write the unit fraction inside each equal-sized part.
Then shade the number of parts Obita ate each day.

- 1 On Monday, Obita ate four $\frac{1}{8}$ -sized parts.



- 2 On Tuesday, Obita ate three $\frac{1}{4}$ -sized parts.



1**More Than 1 Part (continued)**

- 3 On Wednesday, Obita ate five $\frac{1}{3}$ -sized parts.

--	--	--	--	--	--	--



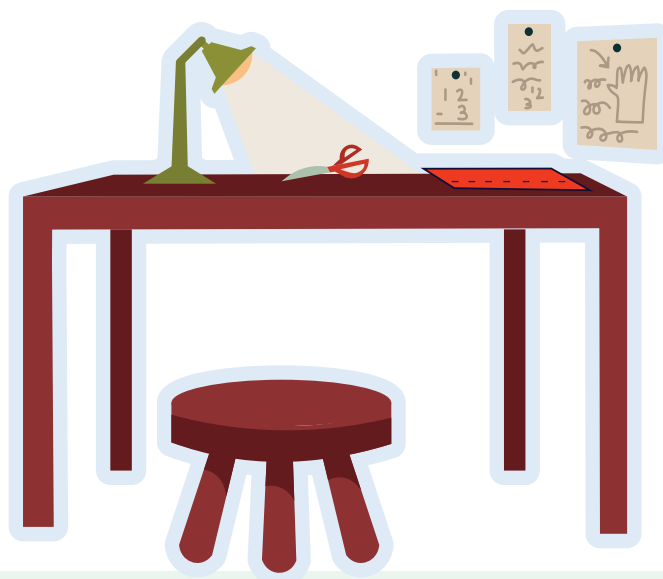

- 4 **Discuss** 

How could you describe the amount of French toast Obita ate each day?



How Much Is Shaded?

- 5 Complete the table to name the fraction of French toast sticks that Obita and Coen ate the following week. Each rectangle represents 1 French toast stick.

	Unit fraction	How many parts are shaded?	Fraction in words	Fraction that is shaded
Monday 				
Tuesday 				
Wednesday 				
Thursday 				
Friday 				

How Much Is Shaded? (continued)

6 How is what they ate on Monday through Wednesday different from what they ate on Thursday and Friday?



Summary 5.04

The **numerator**, or top number in a fraction, tells the number of equal parts being described. The **denominator**, or bottom number in a fraction, tells the number of equal parts in 1 whole. The numerator in a non-unit fraction is a number greater than one and represents more than one equal part of the whole.

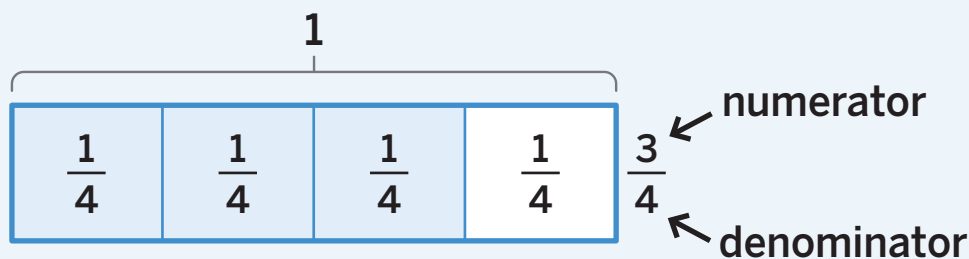

non-unit fraction A fraction that describes more than 1 part of an equipartitioned shape.

Practice 5.04

- 1 Each fraction strip represents a value of 1.



Diego says the fraction $\frac{10}{6}$ represents the fraction model.



Jada says the fraction $\frac{10}{12}$ represents the fraction model.

Who is correct? Explain your thinking.

Practice 5.04

Name _____ Date _____

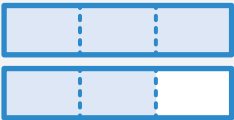
- 2 Clare made pizza sticks one week. Each rectangle represents 1 pizza stick. The shaded parts represent how much Clare ate each day. Complete the table.

	1 part	All shaded parts		
	Unit fraction	How many?	Fraction in words	Fraction
Monday 				
Tuesday 				
Wednesday 				
Friday 				

Practice 5.04

Name _____ Date _____

- 3**  Each square represents a value of 1. Write a fraction that represents the value of *all* the shaded parts in the diagram.

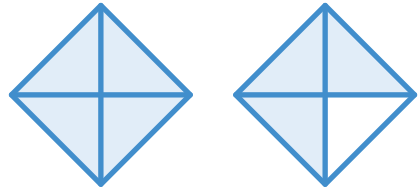

Spiral Review

For Problems 4–7, determine the missing value in the equation.

4 $7 \times ? = 21$ _____

5 $9 \times 9 = ?$ _____

6 $? \times 4 = 20$ _____

7 $6 \times ? = 36$ _____

For Problems 8–13, determine the value of the expression.

8 $12 \div 3$ _____

9 2×7 _____

10 6×4 _____

11 $8 \div 4$ _____

12 $10 \div 2$ _____

13 3×5 _____

What Parts? How Many Parts?

Let's represent non-unit fractions.

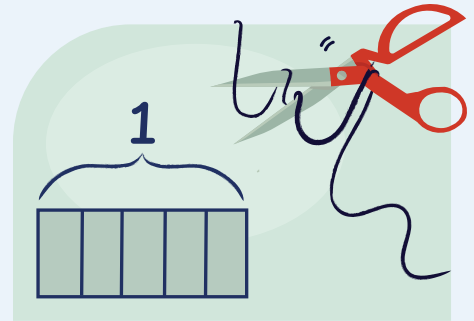

Warm-Up



 eyes on teacher



We are a math community.

Coen and Obita's different sizes gave them different perspectives. When has hearing a different perspective been helpful in math class?

Activity

1

Representing Fractions

Use the rectangles to represent each number. Each rectangle represents 1 whole. Be prepared to explain your thinking.

1 $\frac{5}{8}$

2 $\frac{7}{6}$

1**Representing Fractions (continued)****3** Discuss 

How did you represent $\frac{7}{6}$?

Use the rectangles to represent each number.
Each rectangle represents 1 whole.

4 $\frac{2}{2}$



5 $\frac{7}{8}$



6 $\frac{5}{4}$



2

Tailoring With Fractions

Represent each situation with a diagram. Be prepared to explain your thinking.

 Draw

7 Obita replaced a button using $\frac{3}{4}$ spools of thread.

8 Obita used $\frac{7}{4}$ pieces of ribbon to make a bow.



Tailoring With Fractions (continued) **Draw**

9 Obita fixed a hole in Coen's shirt using $\frac{10}{6}$ spools of thread.

10 Obita used $\frac{4}{8}$ pieces of ribbon to make himself a tablecloth.

11 **Discuss** 

Discuss how you represented Problem 8.

Summary 5.05

When representing a fraction, you can consider the relationship between the numerator and denominator to determine whether the fraction is less than or greater than 1 whole.

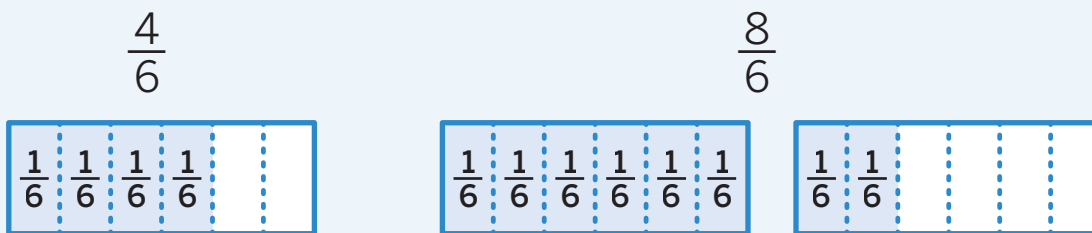

Practice 5.05

- 1 Jada is walking from the Statue of Liberty to a ferry boat. She walks $\frac{3}{4}$ of the way and stops to take a picture. Represent how far Jada has walked on the diagram. Explain your thinking.



For Problems 2–4, each fraction strip represents a value of 1. Use the fraction strips to represent the fraction.

 Draw

2 $\frac{3}{2}$

3 $\frac{12}{6}$

4 $\frac{5}{8}$

5  Which fraction-strip diagram represents $\frac{4}{6}$?



Spiral Review

For Problems 6–9, determine the value of the expression.

6 $15 \div 5$ _____

7 $24 \div 6$ _____

8 7×7 _____

9 6×9 _____

- 10 Jada decomposed the 6×12 rectangle to determine the area. Write a multiplication expression to represent her work and determine the area of the rectangle.

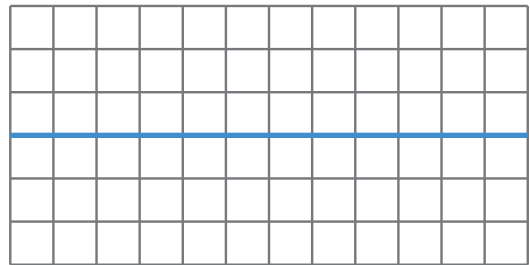

expression: _____

area: _____

For Problems 11–14, determine the missing value in the equation.

11 $5 \times ? = 50$ _____

12 $? \times 6 = 30$ _____

13 $? \times 8 = 72$ _____

14 $7 \times ? = 28$ _____



Notes:

Fractions on the Number Line

✦ Unit Story: Coen and Obita



S_Photo/Shutterstock.com

Every job has a unique set of tools that makes it possible. What tools make math possible for you?

To the Number Line

Let's locate fractions on a number line.



I am a doer of math.
What is a mathematical tool that has helped you better understand an idea before?

Warm-Up



eyes on teacher

Activity

1

Card Sort: Number Lines

You and your partner will be given a set of cards with different number lines.

1 Sort

Arrange the cards into 2, 3, or 4 categories of your choosing. Be prepared to describe each of your categories. Record the letters of all the cards in each category.

Category 1: _____

Category 2: _____

Category 3: _____

Category 4: _____

2 Discuss

Compare your categories with another pair.

2

Where Should It Go?

Locate and label each fraction on the number line. Be prepared to explain your thinking.

3

$\frac{1}{4}$



4

$\frac{1}{2}$



5

$\frac{1}{3}$



6

$\frac{1}{8}$



7

Discuss 

Select 1 fraction from Problems 3–6. Explain how you located the fraction on the number line.

Summary 5.06

Fraction strips and number lines are 2 ways to represent fractions. Each equally-spaced tick mark on a number line represents a specific distance from 0.

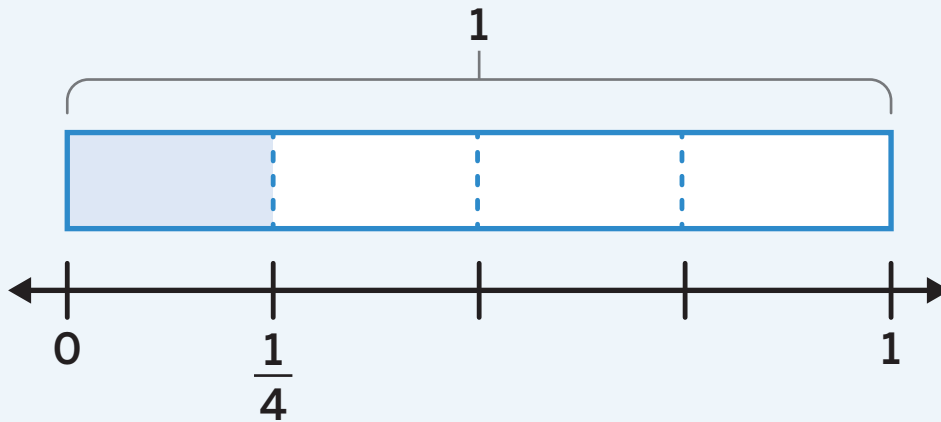

Practice 5.06

- 1 Refer to the fraction strip and number line shown in the Summary. How are they alike? How are they different?

- 2 Locate and label the fraction $\frac{1}{2}$ on the number line.



Practice 5.06

Name _____ Date _____

- 3 Clare says the point on the number line represents $\frac{1}{4}$. Diego says the point represents 1. Who is correct? Explain your thinking.



- 4 Which number line represents the location of $\frac{1}{8}$?



Spiral Review

For Problems 5–8, determine the value of the expression.

5 7×7 _____

6 $18 \div 3$ _____

7 6×8 _____

8 $14 \div 2$ _____

- 9 At a museum, Jada saw 5 dragonfly fossils. Each fossil had 4 dragonfly wings. Determine how many dragonfly wings there were altogether. Then write an equation that represents the situation.



solution: _____ equation: _____

For Problems 10–13, determine the missing value in the equation.

10 $? \times 5 = 45$ _____

11 $? \times 3 = 18$ _____

12 $7 \times 8 = ?$ _____

13 $4 \times ? = 32$ _____

Fractions on the Number Line

Let's locate non-unit fractions on the number line.

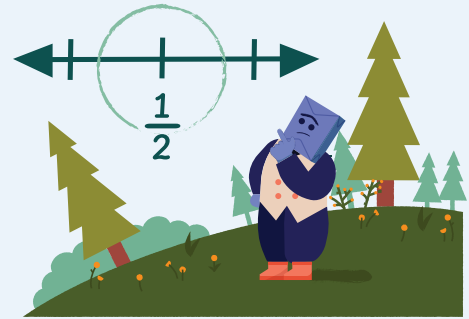

Warm-Up



eyes on teacher

I can be all of me in math class.

When do you prefer to speak first?
When do you prefer to listen to others first?

Activity

1

Hiking Trail

The distance between 0 and 1 on the number line represents the length of the hiking trail.

Locate and label each fraction on the number line to represent how far Coen walked each day. Be prepared to explain your thinking.

1 Monday: $\frac{2}{6}$



2 Wednesday: $\frac{3}{4}$



1**Hiking Trail (continued)**

3 Friday: $\frac{2}{3}$



4 Sunday: $\frac{5}{8}$



5 **Discuss** 

Select 1 fraction from Problems 1–4. Explain how you located the fraction on the number line.

2

More Than 1 Whole

Locate and label each pair of fractions on the same number line.

6 $\frac{2}{3}$ and $\frac{4}{3}$



7 $\frac{5}{6}$ and $\frac{9}{6}$

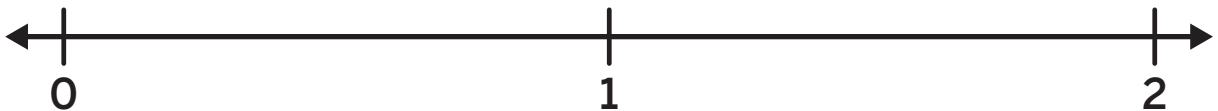

8 $\frac{11}{8}$ and $\frac{15}{8}$

9 **Discuss** 

Compare your number lines with your partner.

What do you notice about the pairs of fractions you located?

Summary 5.07

To locate fractions on a number line, equally partition the distance between whole numbers into the number of parts represented by the denominator. Then count the number of unit fractions to the right of 0 represented by the numerator.

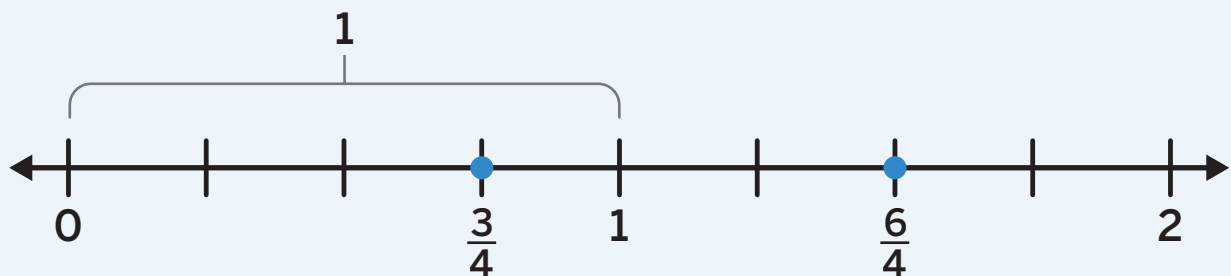

Practice 5.07

- 1 Locate points A and B on the number line. Label each point with the fraction and the letter.

point A : $\frac{5}{4}$ point B : $\frac{2}{4}$

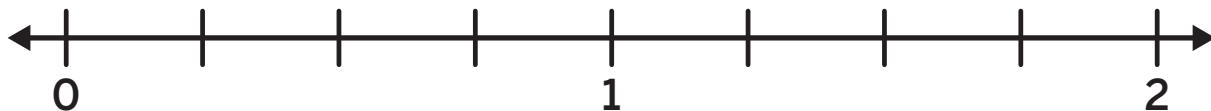

For Problems 2 and 3, locate and label the fraction on the number line.

- 2 $\frac{5}{6}$



3 $\frac{7}{8}$



4 Locate and label a fraction *greater than 1* and a fraction *less than 1* on the number line.

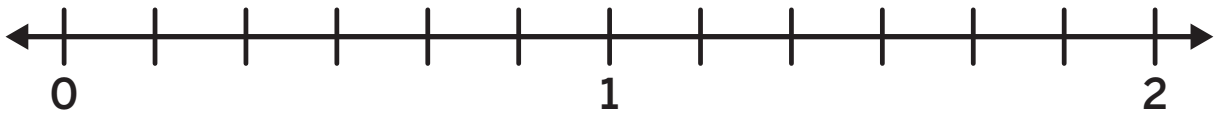

5 Will the fraction $\frac{7}{6}$ be to the right or the left of 1 on a number line? Explain your thinking.

6  What fraction is represented on the number line?

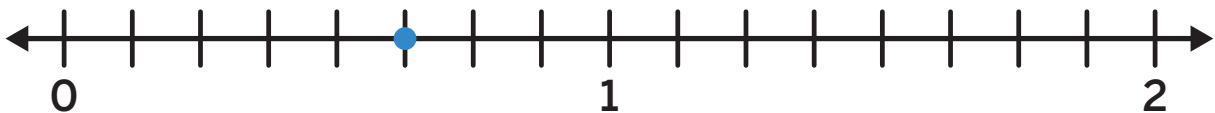

Spiral Review

For Problems 7–12, determine the value of the expression.

7 $24 \div 6$ _____

8 4×9 _____

9 8×2 _____

10 $21 \div 3$ _____

11 $10 \div 2$ _____

12 4×3 _____

For Problems 13 and 14, determine the nearest ten and the nearest hundred to each number.

13 554

nearest ten: _____ nearest hundred: _____

14 89

nearest ten: _____ nearest hundred: _____

Cat Crossing

Let's look at numbers that share the same location on the number line.

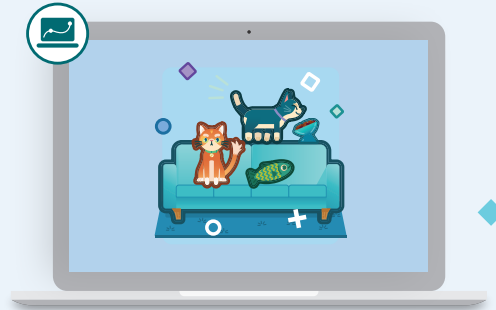

Warm-Up

1 eyes on teacher**I am a doer of math.**

What math ideas have stuck with you from the past few lessons?

Activity

1

Cat-tastic Fractions

Hands-On

You will be given a set of fraction cards. Use the fraction cards for Screens 2 and 3.

2

Describe

Look through the cards. What do you notice?
What do you wonder?

1**Cat-tastic Fractions (continued)****3** Sort 

- Sort the cards into as many categories as you like.
- Create a name for each category, and then complete the table to show how you sorted the cards.
- Share how you sorted the cards with another pair.

Category name	Cards

4 Let's look at some fractions.

Purr-fectly 1 Whole

- 5** Create fractions equal to 1 whole to help the cat reach his food.

 Show your thinking.

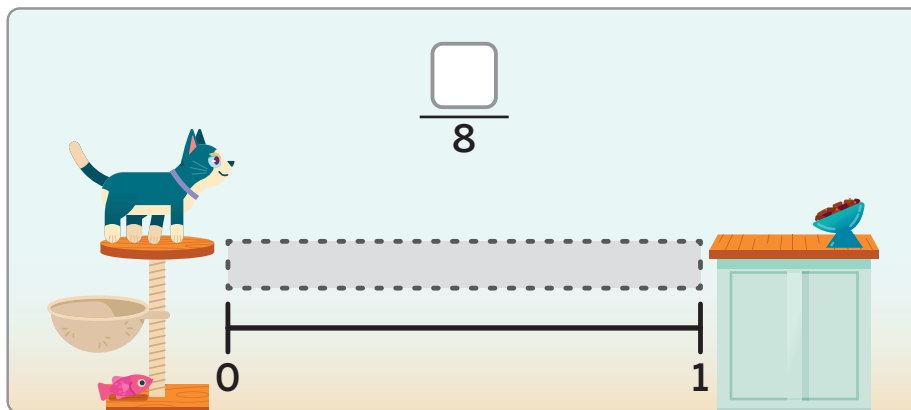
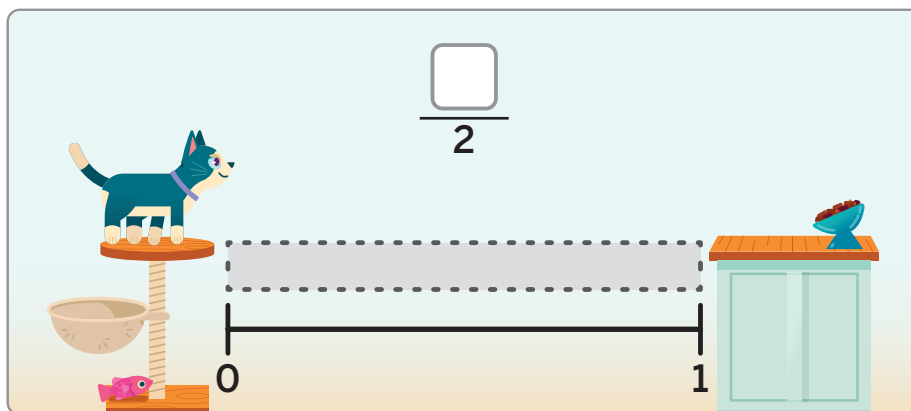

- 5** Describe 

What do you notice and wonder about the fractions you created?

Purr-fectly 1 Whole (continued)

6 Use the digits 1–9 to create fractions equal to 1 whole.

i Show your thinking.

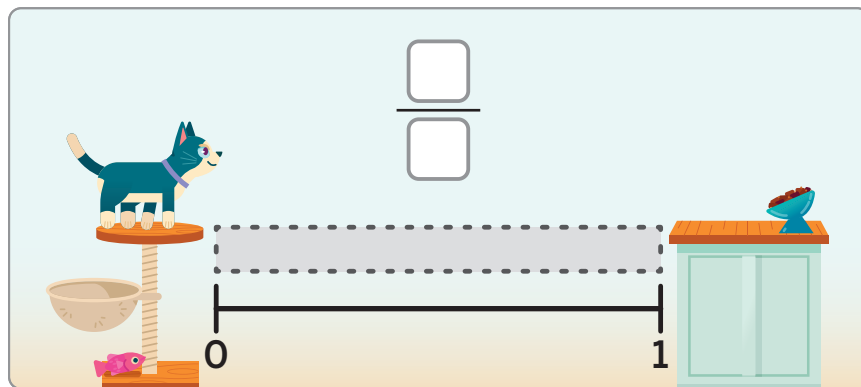
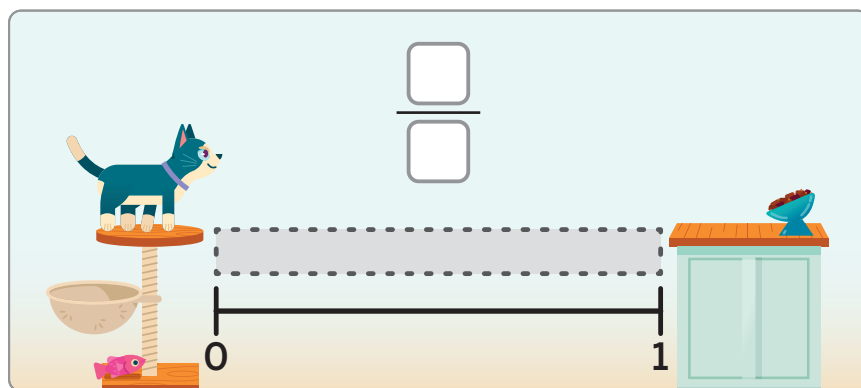
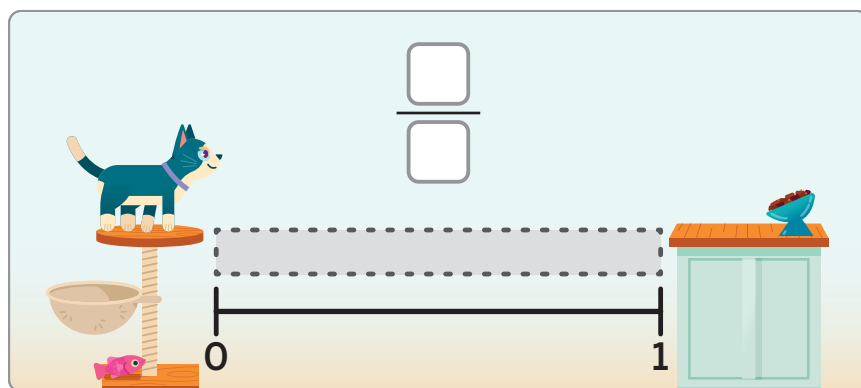

7 Let's look at fractions equal to 1 whole.

Summary 5.08

Fractions at the same location as a whole number are equal to that whole number. Fractions with the same numerator and denominator are equal to 1 whole.

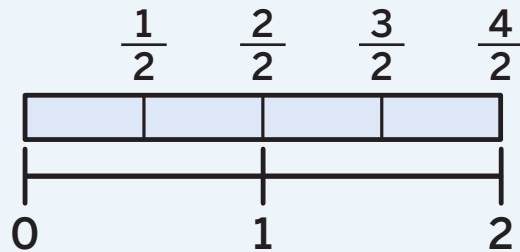

Practice 5.08

- 1 Record 2 fractions that could represent the location of the point on the number line.

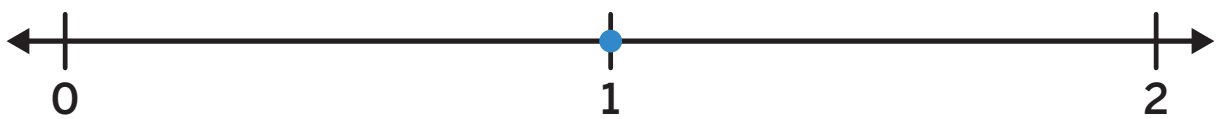

2 Label *all* the tick marks on the number line.



3 Circle the fractions on the number line in Problem 2 that are located at whole numbers and record them here. How do you know these fractions are equal to whole numbers?

4  Select *all* the true statements about points *A* and *B*.

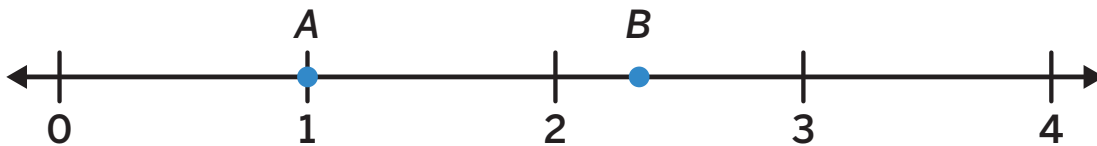

	True	False
(A) The number located at point <i>A</i> is a whole number.		
(B) The number located at point <i>B</i> is a whole number.		
(C) The fraction $\frac{8}{8}$ is located at point <i>B</i> .		
(D) The fraction $\frac{8}{8}$ is located at point <i>A</i> .		

Spiral Review

For Problems 5–10, determine the value of the expression.

5 5×7 _____

6 9×9 _____

7 10×3 _____

8 $18 \div 9$ _____

9 $27 \div 3$ _____

10 $12 \div 4$ _____

For Problems 11 and 12, determine the product of the expression.

 Show your thinking.

11 6×50

answer: _____

12 3×80

answer: _____

13 True or false? The value of the ? in the equation $6 \times ? = 54$ is 8.

Location, Location, Location

Let's use the location of a fraction to locate other numbers.



Warm-Up



eyes on teacher



We are a math community.

Coen and Obita both wanted to feel valued. How can you make our math community a place where everyone feels valued?

Activity

1

Locating 1

The number lines show the location of 0 and a fraction.

Locate 1 on each number line. Label it with a whole number and a fraction.

1



2



1**Locating 1 (continued)****3****4****5**

Explain how you located 1 on the number line in Problem 3.

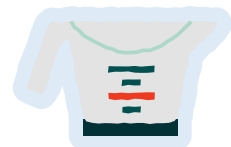

2

Locating Other Fractions

The number lines show the location of 0 and a fraction.

Locate and label the given fractions on the number lines.

Be prepared to explain your thinking.

6

$\frac{1}{3}$



7

$\frac{1}{8}$



8

$\frac{7}{4}$



Locating Other Fractions (continued)

9

Discuss 

How did you locate the unit fractions in Problems 6 and 7?

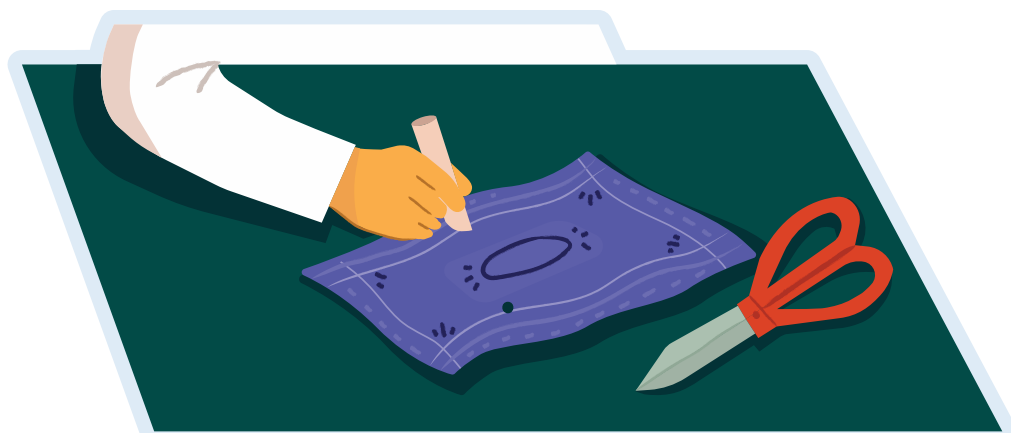

Summary 5.09

Reasoning about the numerator in a non-unit fraction can help you determine the location of a unit fraction. Counting by the distance between 0 and the unit fraction is helpful for locating other fractions on the number line.

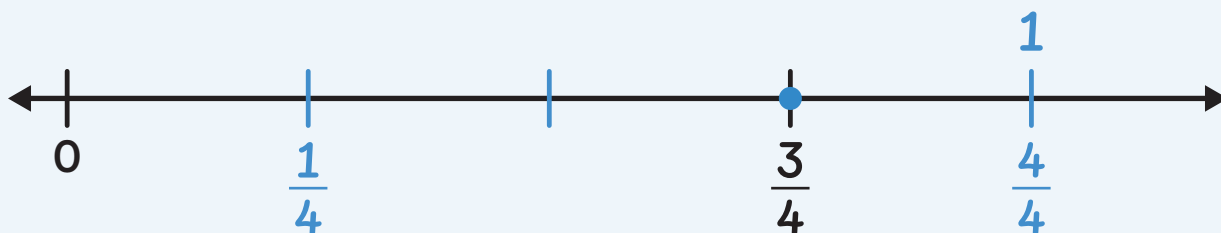

Practice 5.09

For Problems 1 and 2, the number line shows the location of 0 and a fraction. Locate and label the given fraction on the number line.

1

$$\frac{8}{4}$$



2

$$\frac{7}{6}$$



For Problems 3 and 4, locate 1 on the number line and label it with a whole number and a fraction. Then explain your thinking for Problem 3 or 4.

3



4



5

 Which statement about the number line is False?



- (A) The number 1 is located to the left of $\frac{6}{4}$.
- (B) The number 2 is located to the right of $\frac{6}{4}$.
- (C) The fraction $\frac{4}{4}$ is located to the right of $\frac{6}{4}$.
- (D) The fraction $\frac{7}{4}$ is located to the right of $\frac{6}{4}$.

Spiral Review

For Problems 6–9, determine the value of the expression.

6 $8 \div 2$ _____

7 7×7 _____

8 2×6 _____

9 $30 \div 6$ _____

- 10 Gorillas travel in family groups called troops. Suppose a troop has 30 gorillas. How many gorillas would be in 5 troops?

 Show or explain your thinking.

answer: _____

For Problems 11–14, determine the value of the expression.

11 $350 - 150$ _____

12 $200 - 180$ _____

13 $260 + 340$ _____

14 $125 + 225$ _____

Equivalent Fractions

✦ Unit Story: Coen and Obita



Artazum/Shutterstock.com

Things do not have to be identical to be equal.
What is an example of this?

Obita's Quilts

Let's explore equivalent fractions.



Warm-Up

1-2

 eyes on teacher

I am a doer of math.
What helps you understand new ideas in math?

Activity

1

More Than 1 Way

Hands-On 

You and your partner will be given a set of cards with different representations of fractions.

3 Sort the cards into the baskets that show the same shaded area. Record the letters of the matching cards in the table.

Basket	Diagram cards
1	
2	
3	

1**More Than 1 Way (continued)****3****Discuss** 

What strategies did you use to sort the fractions?

4

Let's make a conjecture.

2

The Same, but Different

- 5** Test your conjecture with the challenges on this page. Circle 2 cards in each row that represent the same shaded area.

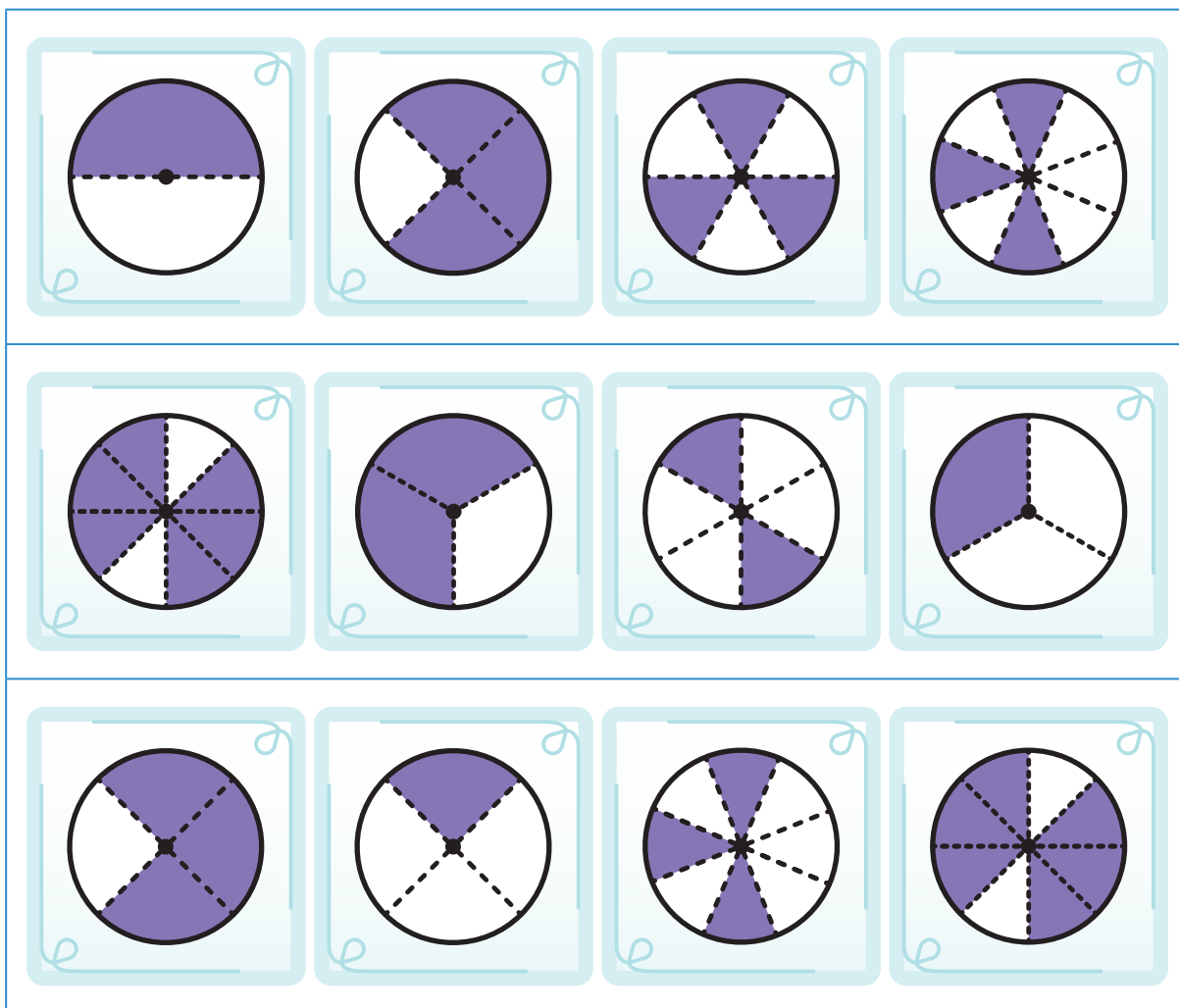

The Same, but Different (continued)

5

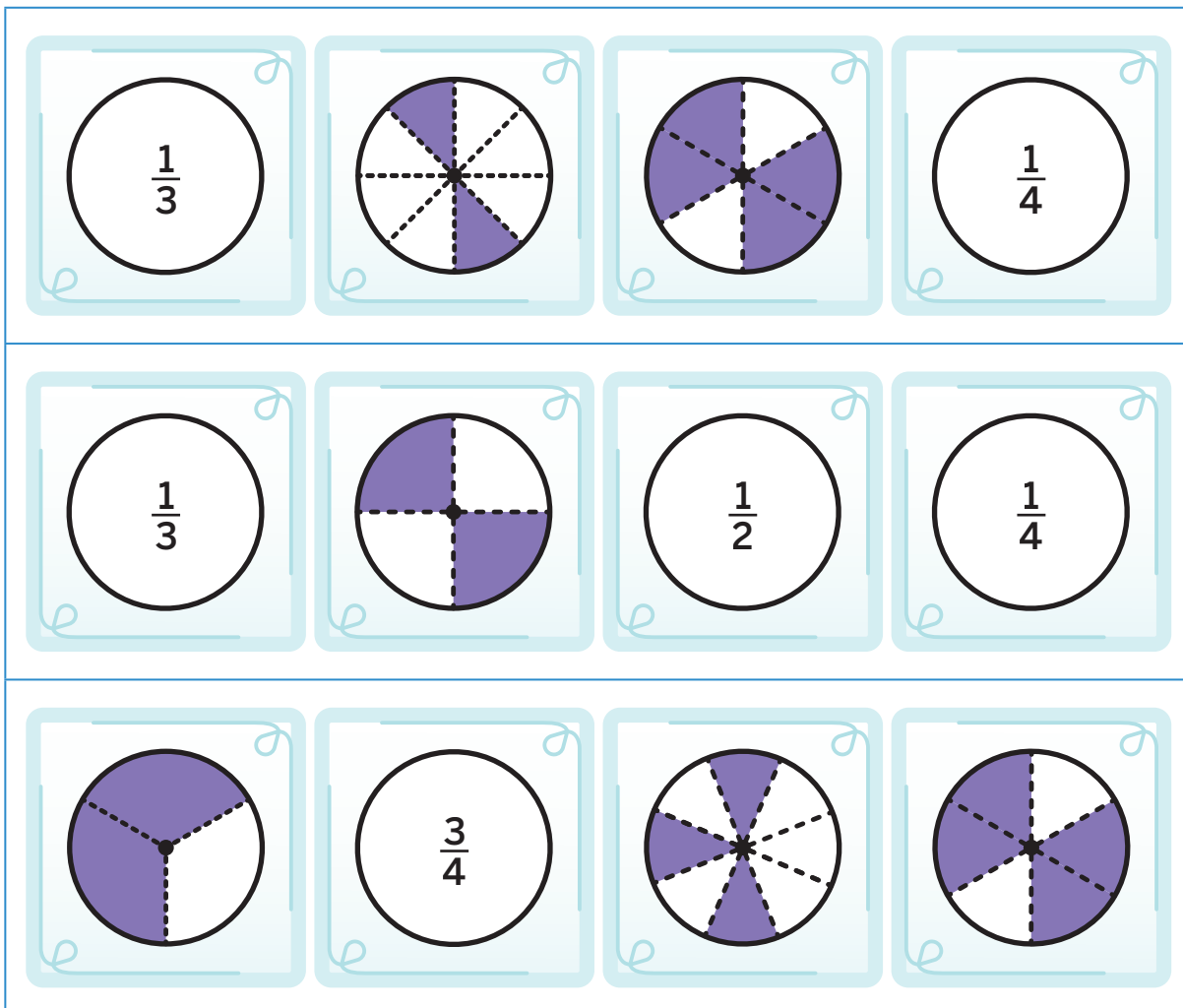

6

Let's talk about our conjecture.

Summary 5.10

When fractions represent the same value, they are **equivalent fractions**.



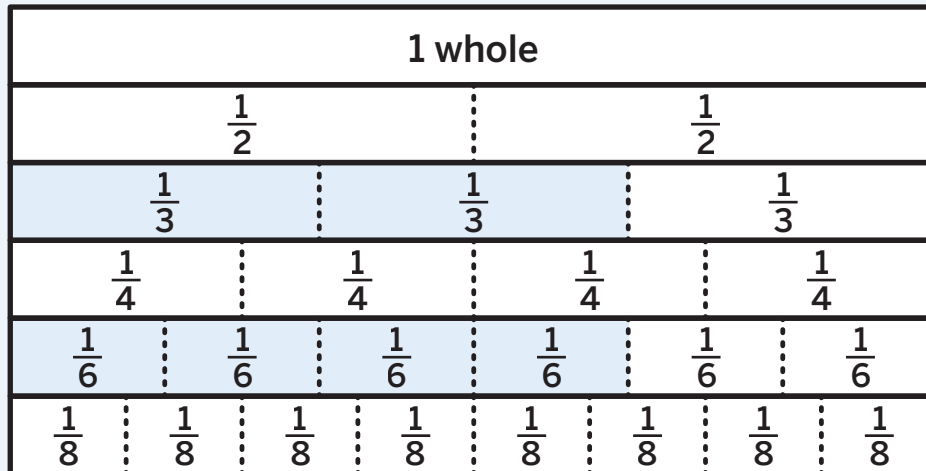

$$\frac{2}{3} = \frac{4}{6}$$



equivalent fractions 2 fractions that represent the same value.

Practice 5.10

- 1 Each diagram represents 1 whole. Select the 2 diagrams in which the total shaded areas represent equivalent fractions.

(A) 	(B) 
(C) 	(D) 

- 2 Name the equivalent fractions from Problem 1.

$\frac{1}{2}$ $\frac{5}{8}$ $\frac{4}{6}$ $\frac{3}{4}$ $\frac{2}{3}$ $\frac{4}{8}$

Practice 5.10

Name _____ Date _____

Each diagram in Problems 3–7 represents 1 whole. Match each diagram on the left with a diagram on the right that represents an equivalent fraction.

Diagram

Equivalent diagram

3



—



4



—



5



—



6



—



7

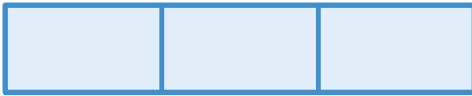

—



8

Select whether each statement is true or false.

	True	False
(A) $\frac{1}{2}$ is equivalent to $\frac{3}{6}$.		
(B) $\frac{1}{2}$ is equivalent to $\frac{1}{3}$.		
(C) $\frac{2}{2}$ is equivalent to $\frac{6}{6}$.		
(D) $\frac{2}{8}$ is equivalent to $\frac{1}{4}$.		
(E) $\frac{2}{3}$ is equivalent to $\frac{4}{6}$.		

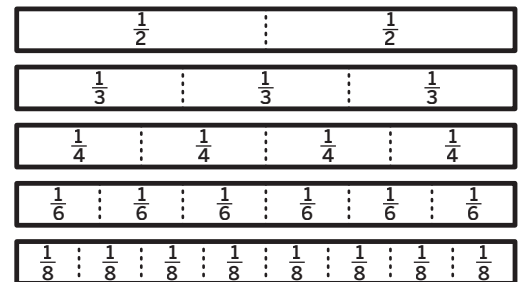

Spiral Review

Use the information for Problems 9 and 10.

A community wants to install a new flower garden. The rectangle represents the flower garden. Each small square represents an area of 1 square foot.

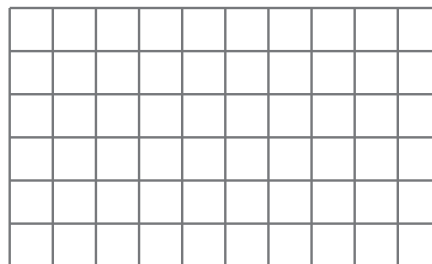

- 9** Draw 1 or more lines on the rectangle to show how you could decompose it to help you determine the area.
- 10** Write 1 or more expressions to represent the area of the rectangle based on how you decomposed it in Problem 9. Then determine the area of the garden.

i Show your thinking.

expression: _____

answer: _____

For Problems 11–14, determine the value of the expression.

11 $8 \div 2$ _____

12 7×7 _____

13 2×6 _____

14 $30 \div 3$ _____

Generating Equivalent Fractions

Let's continue using diagrams and fraction strips to help us think about equivalent fractions.



Warm-Up



eyes on teacher



I am a doer of math.

Think about the story. What math tool or tools could help Obita and Coen?

Activity

1

Equivalent or Not?

Determine whether the fractions are equivalent by drawing diagrams to represent the fractions. Write *yes* or *no*.

 Draw

1 $\frac{1}{3}$ and $\frac{2}{6}$

Are these fractions equivalent? _____

1

Equivalent or Not? (continued)

 Draw

2 $\frac{1}{4}$ and $\frac{3}{6}$

Are these fractions equivalent? _____

3 Discuss 

Han drew the following diagrams and claimed that $\frac{1}{3}$ is not equivalent to $\frac{2}{6}$.

- Identify one thing that Han did correctly.
- What advice would you give Han for how to correct his work?

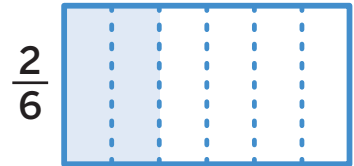

2

More Than 1 Name

Each diagram represents a value of 1. Write 2 different fractions to represent the total shaded area of each diagram.

 Show your thinking.

4



answer: _____

5



answer: _____

More Than 1 Name (continued)



Show your thinking.

6

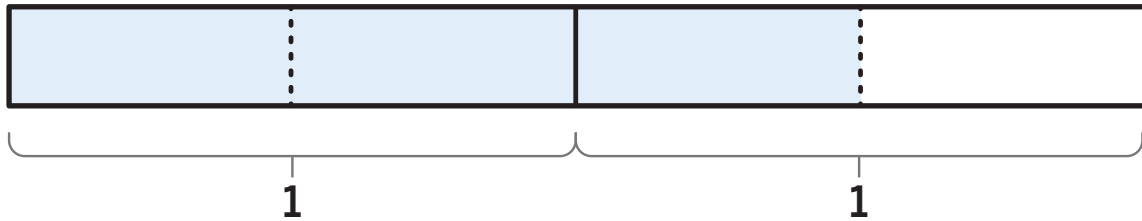

answer: _____



Summary 5.11

When using a diagram to represent 1 fraction, you can partition the diagram into smaller equal parts or combine existing parts to make larger equal parts to see and name equivalent fractions.

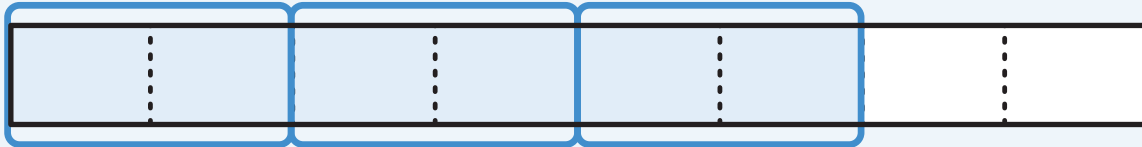

Practice 5.11

- 1 The post office is $\frac{3}{4}$ miles from the school. Clare said this distance can be represented by the fraction $\frac{6}{8}$. Shade the diagrams to represent the actual distance and Clare's distance.



Is Clare correct? _____

For Problems 2 and 3, write as many fractions as you can that represent the total shaded area of the diagram. Each diagram represents a value of 1. Show your thinking on the diagrams.

i Show your thinking.

2



answer: _____

3



answer: _____

4

🔍 Select *all* the fractions that could be represented by the total shaded area of the diagram.

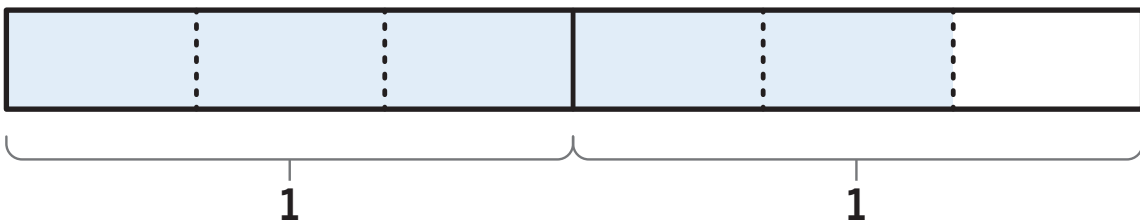

(A) $\frac{5}{3}$

(B) $\frac{4}{3}$

(C) $\frac{8}{6}$

(D) $\frac{3}{3}$

(E) $\frac{10}{6}$

(F) $\frac{6}{4}$

Practice 5.11

Name _____ Date _____

- 5 Select *all* the fractions that represent the shaded area of the diagram. The diagram represents a value of 1.



Ⓐ $\frac{4}{6}$

Ⓑ $\frac{2}{4}$

Ⓒ $\frac{1}{2}$

Ⓓ $\frac{3}{6}$

Ⓔ $\frac{4}{8}$

Ⓕ $\frac{2}{3}$

Spiral Review

For Problems 6–9, determine the value of the expression.

6 $600 + 175$ _____

7 $600 - 390$ _____

8 $260 - 140$ _____

9 $70 + 350$ _____

For Problems 10–13, determine the unknown value in the equation.

10 $9 \times ? = 36$ _____

11 $7 \times 8 = ?$ _____

12 $? \times 10 = 20$ _____

13 $6 \times ? = 48$ _____

Line-Up

Let's explore equivalent fractions on a number line.



Warm-Up



eyes on teacher

I am a doer of math.

How can you be sure to keep an open mind in math class today?

Activity

1

Driving Down the Racetrack

Hands-On

You will be given number lines. Locate the distance of the racetrack that each race car drove and label it with the letter of the car.

Car A	$\frac{1}{4}$	Car B	$\frac{1}{2}$	Car C	$\frac{3}{6}$	Car D	$\frac{2}{4}$
Car E	$\frac{1}{3}$	Car F	$\frac{2}{3}$	Car G	$\frac{2}{6}$	Car H	$\frac{3}{4}$
Car I	$\frac{6}{8}$	Car J	$\frac{2}{8}$	Car K	$\frac{4}{8}$	Car L	$\frac{4}{6}$

1**Driving Down the Racetrack (continued)**

- 1** List the pairs of cars that went the same distance.

- 2** Identify 4 pairs of equivalent fractions. For each pair, write an equation to show that the fractions are equivalent.

- 3** **Discuss** 

How did you determine which fractions were equivalent on the number line?

Number Lines Beyond 1

Identify 1 fraction that is equivalent to the fraction shown on each number line. Then write an equation to show that the fractions are equivalent.

 Show your thinking.

4

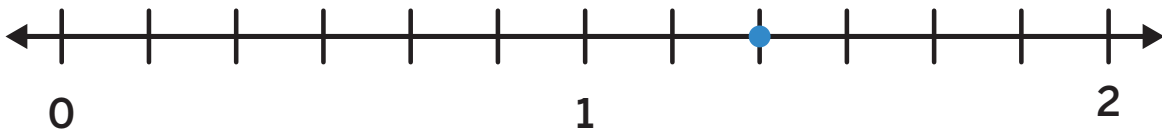
 $\frac{8}{6}$ 

equation: _____

5

 $\frac{5}{2}$ 

equation: _____

Summary 5.12

2 fractions are equivalent if they are located at the same point on the number line. Number lines can also be used to find equivalent fractions by splitting or grouping parts.

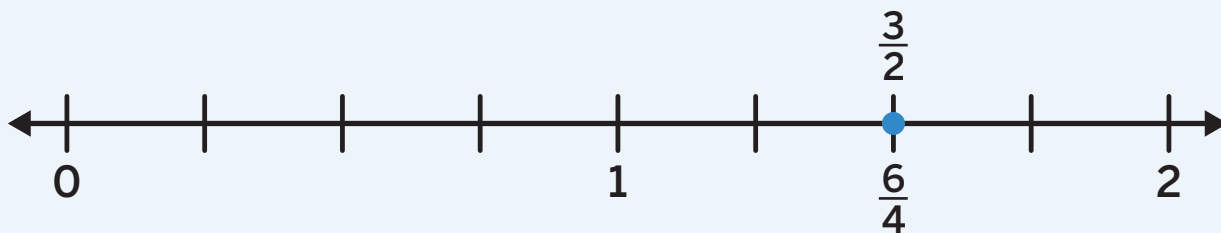

Practice 5.12

- 1 Shawn drew these number lines and said, " $\frac{3}{4}$ is equivalent to $\frac{2}{3}$." Explain why Shawn is *not* correct.

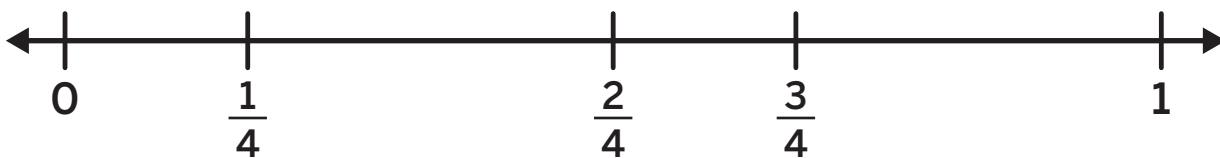

Practice 5.12

Name _____ Date _____

For Problems 2 and 3, write 1 fraction that is equivalent to the fraction. Show your thinking on the number lines.

2 $\frac{2}{3}$

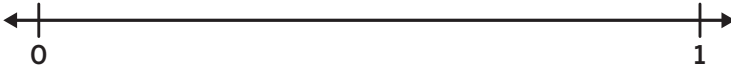

3 $\frac{3}{4}$



For Problems 4 and 5, identify 1 fraction that is equivalent to the fraction shown on the number line. Then write an equation to show that the fractions are equivalent.

4

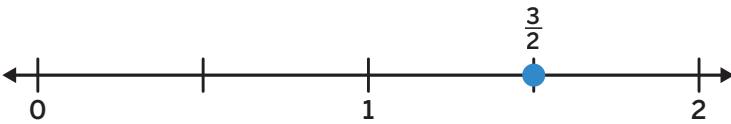

5



Practice 5.12

Name _____ Date _____

- 6 Which fraction is equivalent to the fraction shown on the number line?

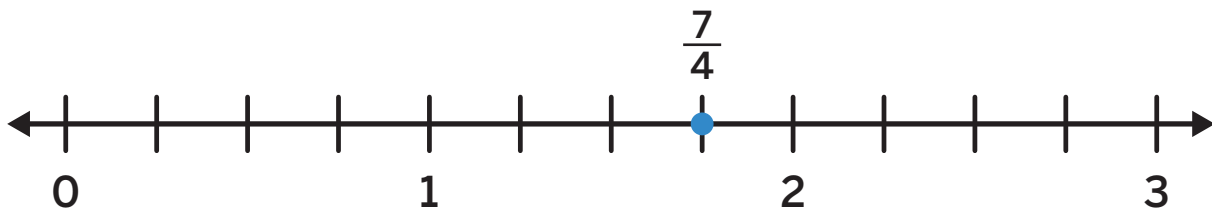

- (A) $\frac{3}{2}$ (B) $\frac{12}{8}$ (C) $\frac{13}{6}$ (D) $\frac{14}{8}$

- 7 Which fraction is equivalent to $\frac{1}{4}$? Use the number line if it is helpful.



- (A) $\frac{3}{8}$ (B) $\frac{2}{8}$ (C) $\frac{2}{6}$ (D) $\frac{3}{6}$

Spiral Review

Use the information for Problems 8–10.

During hibernation, a bat's heart rate can drop to 10 beats per minute. Determine the number of times a hibernating bat's heart beats for the number of minutes.

- 8 5 minutes 9 10 minutes 10 15 minutes

For Problems 11–14, determine the value of the expression.

11 $9 \div 3$ _____

12 $5 \div 5$ _____

13 $16 \div 2$ _____

14 $16 \div 4$ _____

Whole Numbers and Fractions

Let's look at how fractions and whole numbers are related.



Warm-Up



eyes on teacher

We are a math community.

What does it look and sound like to give respectful feedback to our math community?

Activity

1

Hidden Whole Numbers

- 1 Circle *all* the fractions on each number line that are equivalent to whole numbers.

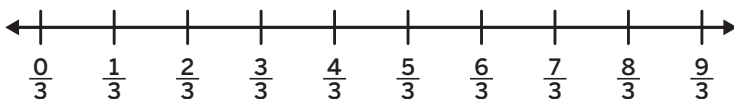
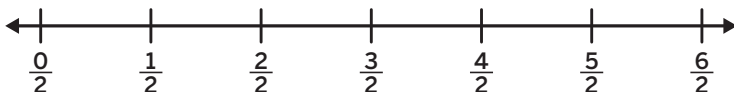

- 2 Choose 1 fraction from Problem 1 that is equivalent to a whole number. Write an equation to show they are equivalent.

1

Hidden Whole Numbers (continued)

3 Discuss 

How do you know that the fractions you wrote in Problem 2 are equivalent?

4 Circle the fractions that are equivalent to whole numbers. Use the number lines to show your thinking.



2

Writing Whole Numbers as Fractions

- 5 Work with your group to complete the table. In each column, write fractions that are equivalent to the whole number in the top row. The fractions in each row should have the same denominator.

Step 1: Write 1 fraction that is equivalent to *each* whole number — 4, 5, and 6 (you should write 3 fractions). Pass your paper to your right.

Step 2: When you receive another paper, write 1 *new* fraction that is equivalent to each whole number (you should write 3 fractions).

Repeat Step 2 until the table is complete.



Writing Whole Numbers as Fractions (continued)

4	5	6
$\frac{8}{2}$	$\frac{\square}{2}$	
		$\frac{\square}{3}$
$\frac{\square}{4}$		
	$\frac{30}{6}$	
		$\frac{48}{8}$

6 Discuss

What patterns do you notice in the fractions that are equivalent to whole numbers in the table?

Summary 5.13

There are many ways to identify equivalent fractions and whole numbers.

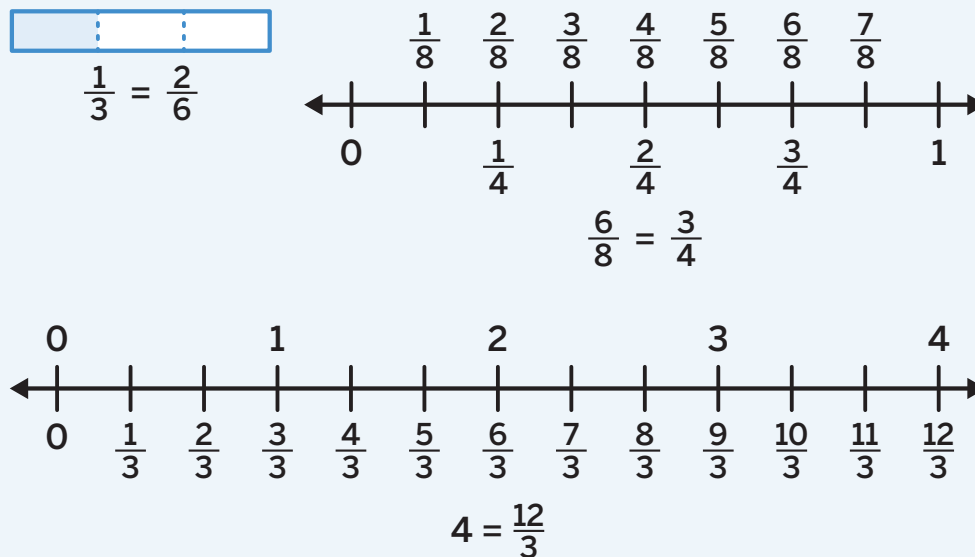

Practice 5.13

1 Is $\frac{10}{8}$ equivalent to a whole number? Write yes or no.

i Show your thinking.



answer: _____

Practice 5.13

Name _____ Date _____

- 2 In each column of the table, write fractions that are equivalent to the whole number in the top row. The fractions in each row should have the same denominator.

7	8	9
		$\frac{27}{3}$
$\frac{42}{6}$		

- 3 Is $\frac{88}{8}$ a whole number? Explain your thinking.

- 4  Select whether each fraction is equivalent to a whole number.

	Yes	No
(A) $\frac{8}{2}$		
(B) $\frac{9}{2}$		
(C) $\frac{13}{6}$		

	Yes	No
(D) $\frac{10}{3}$		
(E) $\frac{9}{3}$		
(F) $\frac{12}{4}$		

Practice 5.13

Name _____ Date _____

5 Which fraction is *not* equivalent to 10?

(A) $\frac{10}{1}$

(B) $\frac{10}{10}$

(C) $\frac{30}{3}$

(D) $\frac{20}{2}$

Spiral Review

For Problems 6–9, determine the value of the expression.

6 $6 \div 2$ _____

7 5×9 _____

8 10×8 _____

9 $24 \div 4$ _____

For Problems 10–13, determine the value of the expression.

10 $224 + 76$ _____

11 $250 - 75$ _____

12 $160 - 130$ _____

13 $80 + 220$ _____

14 Diego bought a sticker of the Texas state flag. What is the area of the sticker?

i Show or explain your thinking.

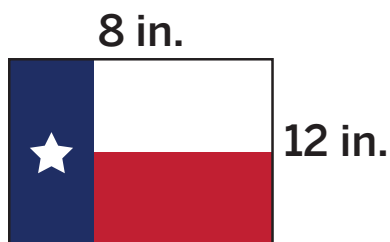

answer: _____

A New Denominator

Let's explore another way to express whole numbers as fractions.

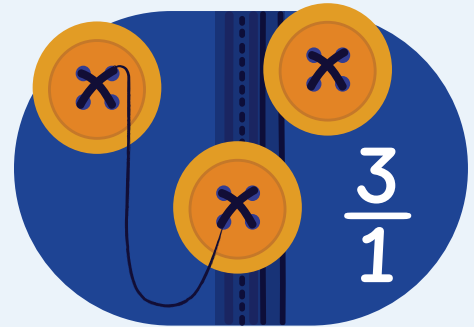

Warm-Up



 eyes on teacher



We are a math community.
What does a collaborative math partner look and sound like?

Activity

1

Sharing Wholes

Solve each problem. Write the answer as a fraction.

- 1 There are 4 granola bars to be shared by 2 basketball players. How many granola bars does each player receive?

 Show your thinking.

answer: _____

1**Sharing Wholes (continued)**

- 2 There are 8 veggie sliders in the cafeteria. 2 students are sharing them for lunch. How many sliders does each student get?

 Show your thinking.

answer: _____

- 3 **Discuss** 

What do you notice about the wholes being shared in Problems 1 and 2? How are these problems different from the problems you have been working with in previous lessons?

Introducing the Center, Mystery Number

Stage 3



Pairs  Let's ask questions to guess the mystery fraction.

You'll need: counters, sticky notes, Gameboard, Recording Sheet



How to Play

- 1 Player A:** Choose a fraction on the Gameboard and record it on a sticky note. Do not show your partner your fraction.
- 2 Player B:** Ask as many *yes* or *no* questions as you need to help you identify the mystery fraction. Consider using words such as *numerator*, *denominator*, *greater than*, *less than*, *equivalent*, or *whole* when you ask your questions. Record notes to help you remember each question and your partner's response.
- 3 Player B:** Cover up fractions as you determine they are not the mystery fraction. When you are ready, you have one guess to identify the mystery fraction. Record the fraction you guess. If you are correct, you earn 1 point.
- 4** Switch roles and repeat to complete Round 1.



How to Win Play 2 rounds. The player who earns more points wins.

Mystery Number (continued)

Round 1							My guess:	Correct number:
Questions								Number

Summary 5.14

Whole numbers can be written as fractions with a denominator of 1. When describing fractions, it is helpful to describe the numerator, denominator, and their equivalence to other numbers.

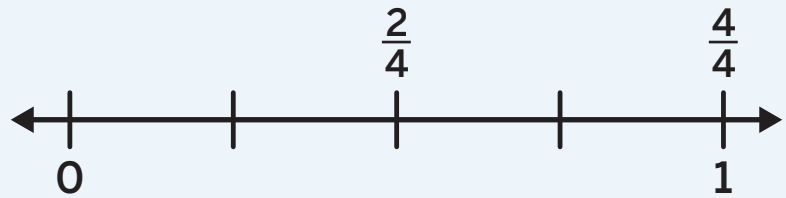
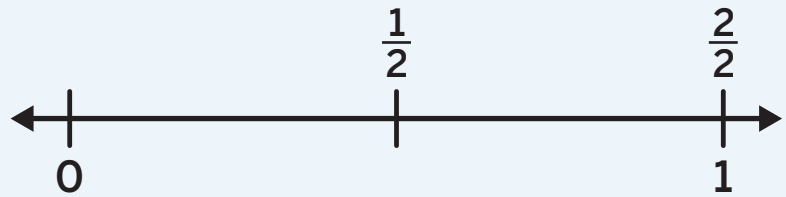
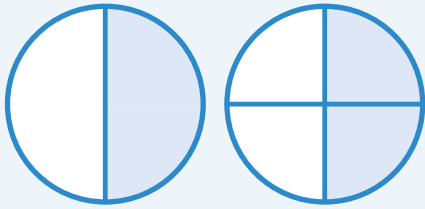

Practice 5.14

- 1 There are 9 slices of bread to be shared by 3 teachers. How many slices of bread does each teacher receive? Write your answer as a fraction.

 Show your thinking.

answer: _____

- 2** There are 6 bags of pretzels for 3 students to share during snack time. How many bags of pretzels does each student get? Write your answer as a fraction.

 **Show your thinking.**

answer: _____

- 3** Is $\frac{15}{1}$ a whole number? Write *yes* or *no*. Explain your thinking.

Practice 5.14

Name _____ Date _____

4 Select *all* the fractions that are equivalent to whole numbers.

	Yes	No
(A) $\frac{5}{2}$		
(B) $\frac{9}{1}$		
(C) $\frac{12}{6}$		

	Yes	No
(D) $\frac{11}{3}$		
(E) $\frac{21}{3}$		
(F) $\frac{11}{4}$		

5 Which fraction is *not* equivalent to 5?

(A) $\frac{5}{5}$

(B) $\frac{5}{1}$

(C) $\frac{30}{6}$

(D) $\frac{10}{2}$

Spiral Review

For Problems 6–11, determine the value of the expression.

6 $9 \div 3$ _____

7 5×9 _____

8 6×8 _____

9 $24 \div 8$ _____

10 7×3 _____

11 $40 \div 5$ _____

For Problems 12–15, determine the value of the expression.

12 $123 + 72$ _____

13 $150 - 75$ _____

14 $338 + 17$ _____

15 $225 - 32$ _____



Notes:

Fraction Comparisons

✦ Unit Story: Coen and Obita



ppa/Shutterstock.com

It took some time for Coen and Obita to become friends. What is something related to your math learning journey that took you some time?

Seams About Right

Let's compare unit fractions.

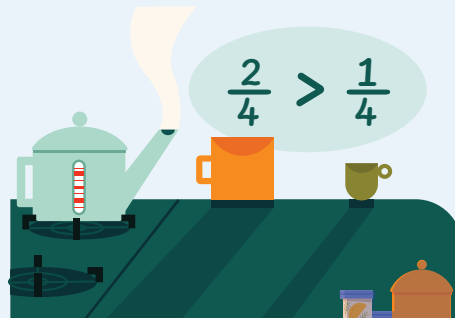

Warm-Up



eyes on teacher



I am a doer of math.

What can you do when you feel stuck on a math problem?

Activity

1

Which Representation?

Use any representation to compare the 2 fractions. Then answer the question. Be prepared to explain your thinking.

i Show your thinking.

1 $\frac{1}{6}$ and $\frac{1}{2}$

2 $\frac{1}{3}$ and $\frac{1}{8}$

Which fraction is greater? _____

Which fraction is smaller? _____

Bigger, Smaller, Fewer, More

- 3 The Humane Society needs blankets for large breed dogs. Obita thinks they should use $\frac{1}{4}$ of the fabric for each blanket. Coen thinks they should use $\frac{1}{6}$ of the fabric for each blanket. Do you agree with Obita or Coen?

Use the space below to show your thinking.

 Show or explain your thinking.

Do you agree with Obita or Coen? Why?

Summary 5.15

When comparing fractions, the size of the whole must be the same. Diagrams and number lines can be used to represent and compare fractions. If a whole is partitioned into more parts, each part will be smaller in size.

$$\frac{1}{2} > \frac{1}{6}$$

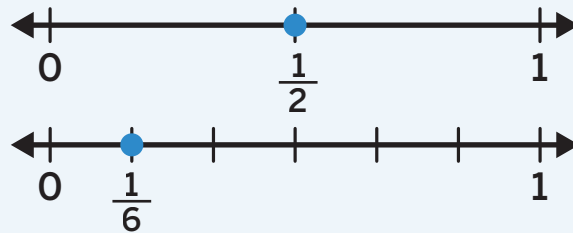

Practice 5.15

- 1 Which fraction is greater $\frac{1}{2}$ or $\frac{1}{3}$?

 Show your thinking.

answer: _____

- 2 Han says that $\frac{1}{4}$ of a sandwich is larger than $\frac{1}{2}$ of the same sandwich because 4 is greater than 2. Do you *agree* or *disagree*?

 **Show or explain your thinking.**

answer: _____

- 3 Which fraction is greater: $\frac{1}{3}$ or $\frac{1}{6}$?

 **Show or explain your thinking.**

answer: _____

- 4  Each person has the same-sized loaf of bread. The table shows the number of equal-sized pieces in each person's loaf of bread.

Person	Number of equal-sized pieces
Clare	2
Diego	8
Han	4
Jada	6

Which fraction represents the *smallest* equal-sized piece of bread?

- (A) $\frac{1}{8}$ (B) $\frac{1}{2}$ (C) $\frac{1}{6}$ (D) $\frac{1}{4}$

Spiral Review

For Problems 5–8, determine the value of the expression.

5 3×2 _____

6 $36 \div 6$ _____

7 7×9 _____

8 $30 \div 3$ _____

For Problems 9–12, determine the missing value in the equation.

9 $5 \times ? = 45$ _____

10 $7 \times 3 = ?$ _____

11 $? \times 4 = 32$ _____

12 $6 \times ? = 54$ _____

Name _____ Date _____

Fractions of Shape and Time

Fractions as Relationships

Unit Fraction Models

3.NF.3.d, 3.NF.3, SMP.7, SMP.8

Same Number of Parts

Let's compare other fractions with the same numerator.

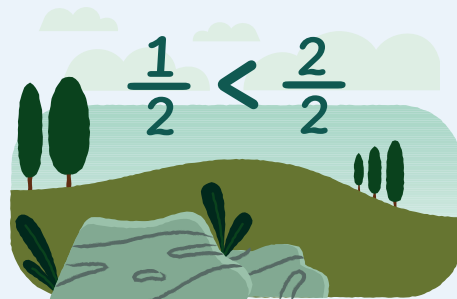

Warm-Up



eyes on teacher

**We are a math community.**

Who do you like to do math with? Why?

Activity

1

Which Is Greater?

Complete the statement using <, >, or =.



Show or explain your thinking.

1

$$\frac{1}{3} \text{ ————— } \frac{1}{4}$$

1**Which Is Greater? (continued)**

 Show or explain your thinking.

2 $\frac{2}{4}$ _____ $\frac{2}{3}$

3 $\frac{5}{8}$ _____ $\frac{5}{6}$

4 $\frac{3}{6}$ _____ $\frac{3}{3}$

5 Discuss 

How did you compare the fractions in Problem 2?

One Numerator, Many Fractions

Fill in the missing denominators to make each statement true.



Show or explain your thinking.

6

$$\frac{2}{6} < \frac{2}{\square}$$

7

$$\frac{5}{4} < \frac{5}{\square}$$

8

$$\frac{6}{\square} > \frac{6}{4}$$

One Numerator, Many Fractions (continued)

 Show or explain your thinking.

9 $\frac{7}{\square} > \frac{7}{\square}$

- 10 For Problem 9, how did you create numbers that made the statement true? Explain your thinking.



Summary 5.16

When fractions that refer to the same whole have the same numerator, they have the same number of parts. When this happens, you can compare the size of the parts.

$$\frac{1}{6} < \frac{1}{4} \quad \frac{2}{6} < \frac{2}{4} \quad \frac{3}{6} < \frac{3}{4}$$

Practice 5.16

- 1** Clare was given the statement $\frac{2}{3} > \frac{2}{?}$ and the numbers 2, 3, 4, 6, and 8 to use as denominators. She said that only 6 and 8 would make the statement true. Do you agree with Clare? Write *yes* or *no*.

i Show or explain your thinking.

answer: _____

For Problems 2–4, complete the statement using $<$, $>$, or $=$.

2 $\frac{2}{2}$ _____ $\frac{2}{6}$

3 $\frac{4}{3}$ _____ $\frac{4}{8}$

4 $\frac{8}{8}$ _____ $\frac{8}{4}$

5 Show or explain your thinking for one of the statements in Problems 2–4.

Practice 5.16

Name _____ Date _____

- 6**  Select whether each statement is true or false.

	True	False
$\frac{5}{3} > \frac{5}{4}$		
$\frac{9}{4} > \frac{9}{3}$		
$\frac{3}{5} < \frac{3}{4}$		
$\frac{4}{4} < \frac{4}{3}$		
$\frac{2}{6} < \frac{2}{4}$		

For Problems 7–10, determine the value of the expression.

- 7** $133 + 67$ _____ **8** $199 - 98$ _____
- 9** $260 - 220$ _____ **10** $600 + 150$ _____

Spiral Review

For Problems 11–14, determine the value of the expression.

- 11** 3×7 _____ **12** $30 \div 6$ _____
- 13** 9×8 _____ **14** $12 \div 2$ _____

Ruby the Red Panda

Let's compare fractions with the same denominator.

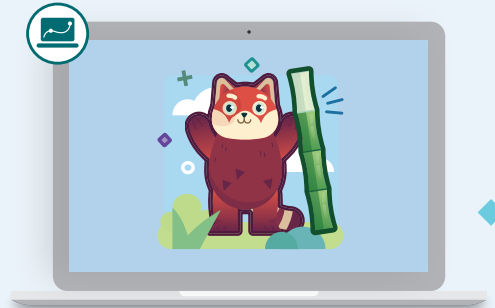

Warm-Up

1

eyes on teacher

I can be all of me in math class.

What are some of your strengths that you used to help you do the math in this unit?

Activity

1

One Denominator, Many Fractions

2

Explain

What strategy can you use to compare these fractions? Use $<$, $=$, or $>$ to make the statement true.

1

One Denominator, Many Fractions (continued)

- 3** Use one of the symbols $<$, $=$, or $>$ to compare the fractions.

i Show or explain your thinking.

$$\frac{4}{6} \text{ — } \frac{2}{6}$$

- 4** Use one of the symbols $<$, $=$, or $>$ to compare the fractions.

i Show or explain your thinking.

$$\frac{2}{4} \text{ — } \frac{3}{4}$$

- 5** Write a different number for each missing numerator that makes each statement true.

$$\frac{5}{8} < \frac{\square}{8}$$

$$\frac{5}{8} < \frac{\square}{8}$$

$$\frac{5}{8} < \frac{\square}{8}$$

$$\frac{5}{8} < \frac{\square}{8}$$

$$\frac{5}{8} < \frac{\square}{8}$$

$$\frac{5}{8} < \frac{\square}{8}$$

- 6** Discuss 

How can you compare 2 fractions with the same denominator?

2

Comparison Scramble

7 Explain 

Priya said that $\frac{4}{8} = \frac{4}{6}$ because each fraction has the same number of pieces. Do you agree? Why or why not?

8 Use one of the symbols $<$, $=$, or $>$ to make each statement true.

 Show or explain your thinking. _____

$$\frac{8}{3} \text{ — } \frac{8}{6}$$

$$\frac{2}{4} \text{ — } \frac{1}{4}$$

$$\frac{3}{6} \text{ — } \frac{3}{3}$$

8 Discuss 

What strategies did you use to compare the fractions?

Comparison Scramble (continued)

- 9** Write a numerator or denominator to make each statement true.

$$\frac{2}{3} < \frac{\square}{3}$$

$$\frac{1}{6} < \frac{1}{\square}$$

$$\frac{2}{\square} > \frac{2}{3}$$

$$\frac{\square}{8} < \frac{5}{8}$$

$$\frac{2}{6} > \frac{2}{\square}$$

$$\frac{6}{2} > \frac{\square}{2}$$

$$\frac{\square}{4} < \frac{8}{4}$$

$$\frac{3}{\square} > \frac{3}{4}$$

- 10** Let's compare the strategies you could use to make these statements true.

$$\frac{2}{4} < \frac{\square}{4}$$

$$\frac{2}{4} > \frac{2}{\square}$$



Summary 5.17

When fractions that refer to the same whole have the same denominator, the size of the parts is the same. When this happens, a fraction with a greater numerator is greater than a fraction with the same denominator and a lesser numerator.

$$\frac{5}{8} > \frac{3}{8}$$

$$\frac{4}{6} > \frac{2}{6}$$

$$\frac{1}{4} < \frac{3}{4}$$

Practice 5.17

For Problems 1 and 2, write a numerator or denominator to make the statement true.

1 $\frac{5}{4} < \frac{\square}{4}$

2 $\frac{3}{8} < \frac{3}{\square}$

For Problems 3 and 4, use $<$, $>$, or $=$ to make the statement true.

3 $\frac{5}{6}$ _____ $\frac{2}{6}$

4 $\frac{4}{3}$ _____ $\frac{8}{3}$

Practice 5.17

Name _____ Date _____

- 5  Han said, "There is no fraction with a denominator of 8 that is greater than $\frac{8}{8}$ because $\frac{8}{8}$ is equivalent to 1." Do you agree with Han?

 Show or explain your thinking.

answer: _____

- 6  Select whether each statement is true or false.

	True	False
$\frac{4}{4} > \frac{3}{4}$		
$\frac{5}{3} < \frac{4}{3}$		
$\frac{3}{6} > \frac{3}{4}$		
$\frac{1}{6} < \frac{1}{2}$		
$\frac{3}{8} > \frac{4}{8}$		
$\frac{2}{2} > \frac{1}{3}$		

Spiral Review

For Problems 7–10, determine the value of the expression.

7 5×9 _____

8 $6 \div 2$ _____

9 8×8 _____

10 $16 \div 8$ _____

- 11 A cow has 4 stomachs. Suppose a farmer has 40 cows. Determine the number of cow stomachs.

 Show or explain your thinking.

answer: _____

For Problems 12 and 13, determine the nearest ten and the nearest hundred for the number.

12 26

nearest ten: _____

nearest hundred: _____

13 109

nearest ten: _____

nearest hundred: _____



Notes:

Math at Work

Do you like to sew, or know someone who sews? Reading a tape measure can be an important part of the process. Where do you see fractions on this tape measure? What fractions do you see?



Tailors create or alter clothes or other items so that they fit people better. Some tailors create costumes for television, movies, or plays. They might work with measurements that are fractions.



New Africa/Shutterstock.com

Math at Home

Use diagrams or number lines to show an adult at home how you can compare 2 fractions . . .

- With the same numerator, such as $\frac{3}{8}$ and $\frac{3}{6}$.
- With the same denominator, such as $\frac{3}{8}$ and $\frac{5}{8}$.

Math Mindset

Think of a whole number.
How can you write this number as a fraction?

Unit 6

Measuring Length, Time, Liquid Volume, and Weight

Big Ideas in This Unit

CC1 Represent Multivariable Data” Measuring

Fractions of Shape and Time CC4 Unit Fraction Models

CC2 Addition and Subtraction Patterns Number Flexibility to 100

Questions for Investigation

- How can we represent length data on a line plot?
- How can we estimate, measure, and solve problems about volumes of liquids and weights of objects?
- How do we tell time to the minute and solve problems about elapsed time?



Unit Story: Just Stick With It, Sasha

In this story, Sasha learns about the patience and responsibility needed to raise a show chicken for a county fair competition.



Explore: Egg-cellent Pick

Which chick should Sasha pick?

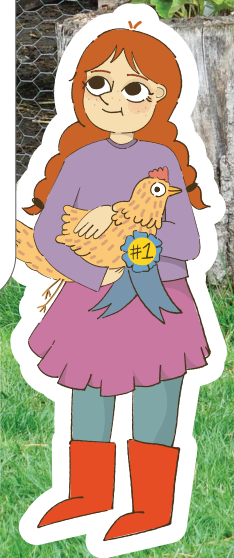

Watch Your Knowledge Grow

This is the math you'll explore in this unit. Rate your understanding to see how your knowledge grows!

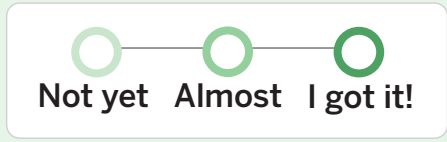

I can . . .	Before	After
Generate measurement data by measuring length using a ruler marked with halves and fourths of an inch.	<input type="radio"/> — <input type="radio"/> — <input type="radio"/>	<input type="radio"/> — <input type="radio"/> — <input type="radio"/>
Show the data by making a line plot marked with whole numbers, halves, or quarters.	<input type="radio"/> — <input type="radio"/> — <input type="radio"/>	<input type="radio"/> — <input type="radio"/> — <input type="radio"/>
Measure and estimate the masses of objects using grams and kilograms.	<input type="radio"/> — <input type="radio"/> — <input type="radio"/>	<input type="radio"/> — <input type="radio"/> — <input type="radio"/>
Measure and estimate liquid volumes of objects using liters.	<input type="radio"/> — <input type="radio"/> — <input type="radio"/>	<input type="radio"/> — <input type="radio"/> — <input type="radio"/>
Tell and write time to the nearest minute, and measure time intervals in minutes.	<input type="radio"/> — <input type="radio"/> — <input type="radio"/>	<input type="radio"/> — <input type="radio"/> — <input type="radio"/>
Solve word problems involving addition and subtraction of time intervals in minutes.	<input type="radio"/> — <input type="radio"/> — <input type="radio"/>	<input type="radio"/> — <input type="radio"/> — <input type="radio"/>
Represent time intervals on a number line diagram.	<input type="radio"/> — <input type="radio"/> — <input type="radio"/>	<input type="radio"/> — <input type="radio"/> — <input type="radio"/>
Compare fractions to intervals of time.	<input type="radio"/> — <input type="radio"/> — <input type="radio"/>	<input type="radio"/> — <input type="radio"/> — <input type="radio"/>
Add, subtract, multiply, or divide to solve one-step word problems involving masses or volumes.	<input type="radio"/> — <input type="radio"/> — <input type="radio"/>	<input type="radio"/> — <input type="radio"/> — <input type="radio"/>
Write story problems about measurements including time, volume, and mass.	<input type="radio"/> — <input type="radio"/> — <input type="radio"/>	<input type="radio"/> — <input type="radio"/> — <input type="radio"/>

Measurement Data on Line Plots

✦ Unit Story: Just Stick With It, Sasha

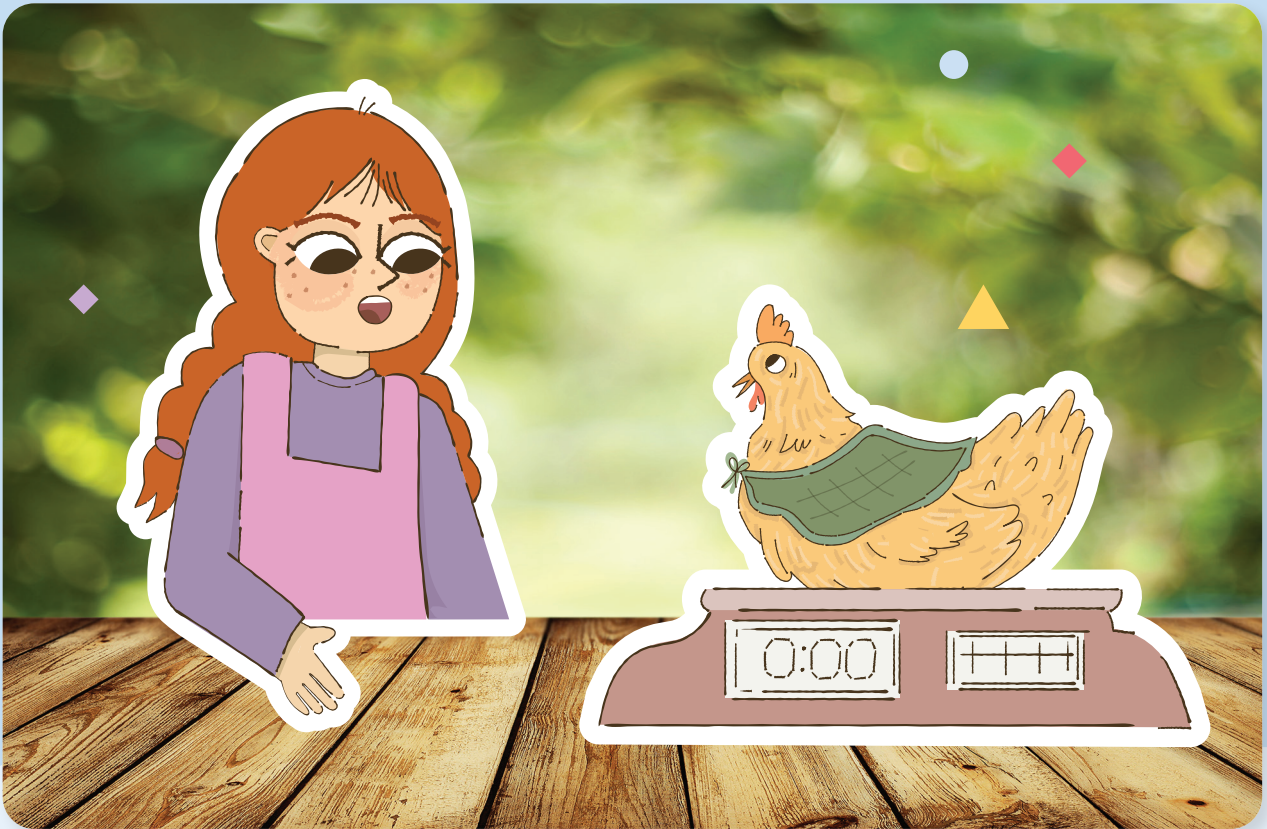

Piotr Krzeslak/Shutterstock.com

The judges at the county fair measure different parts of the chicken for the competition.

How could they keep track of their measurements?

Explore:

Egg-cellent Pick

Which chick should Sasha pick?



I can be all of me in math class.
What data do you have about how you have grown over time?

Warm-Up



eyes on teacher

Discuss What do you notice? What do you wonder?

Just Stick With It, Sasha

Unit Story

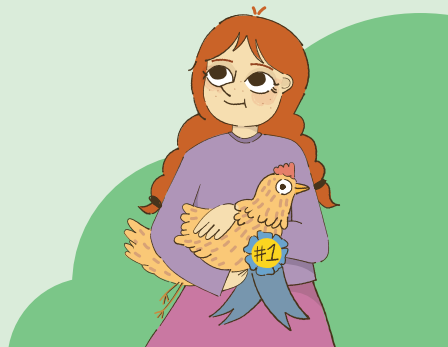



You will be given pictures of 3 chicks at 3 days old and 5 days old.

- Consider the growth of each chick to decide which one Sasha should choose.
- Create a poster using mathematical language to justify your recommendation.

Ways to be a mathematician

- 1** I can take my time to think about a challenging problem before trying to solve it.

○ ——— ○ ——— ○
Not yet Almost I got it!



- 2** I can explain why my thinking makes sense and ask questions to understand the thinking of others.

○ ——— ○ ——— ○
Not yet Almost I got it!

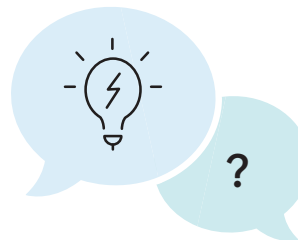

- 3** I can work carefully and try to be clear when I share my ideas.

○ ——— ○ ——— ○
Not yet Almost I got it!

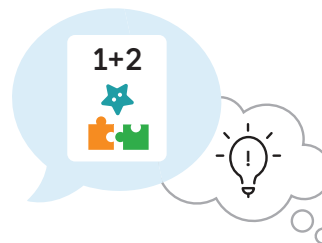

How Long Is It?

Let's measure length in halves of an inch.

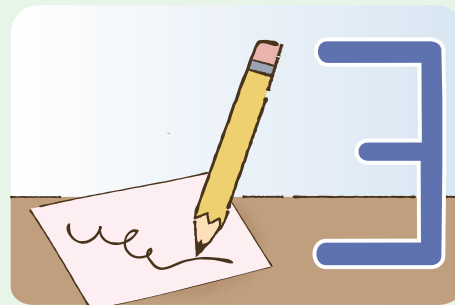

Warm-Up



eyes on teacher



I am a doer of math.

When has a math skill you learned previously helped you learn a new skill?

Activity

1

Partitioning Inches

You will be given a paper inch (in.) ruler.

- Partition every inch on the ruler into halves of an inch.
- Use the ruler to measure the lengths of 4 objects around the room. Record the object and its length.

Object	Length (in.)

Object	Length (in.)

3 Discuss

How is measuring in half inches similar to and different from measuring in whole inches?

Looking for Lengths

Hands-On

You will need the paper inch ruler you partitioned in Activity 1.

4 With your partner:

- Find objects in the classroom that have the lengths shown in the table.
- Record the objects in the table. When you measure an object for the last row, write the exact measurement.

Object	Length (in.)
	$\frac{8}{2}$
	$2\frac{1}{2}$
	4
	$8\frac{1}{2}$
	a whole number and $\frac{1}{2}$

Summary 6.02

You can use rulers to measure in half inches. Numbers that combine whole numbers and fractions less than 1 are called **mixed numbers**.

$$\frac{0}{2} \quad \frac{1}{2} \quad \frac{2}{2} \quad \frac{3}{2} \quad \frac{4}{2} \quad \frac{5}{2} \quad \frac{6}{2} \quad \frac{7}{2} \quad \frac{8}{2} \quad \frac{9}{2}$$



$$4 \frac{1}{2}$$

$$\frac{9}{2} \text{ can be written as } 4 \frac{1}{2}.$$

mixed number A number expressed as a whole number and a fraction less than 1.

Practice 6.02

For Problems 1–6, measure the length of the object to the nearest half inch using your paper inch ruler.

1



2

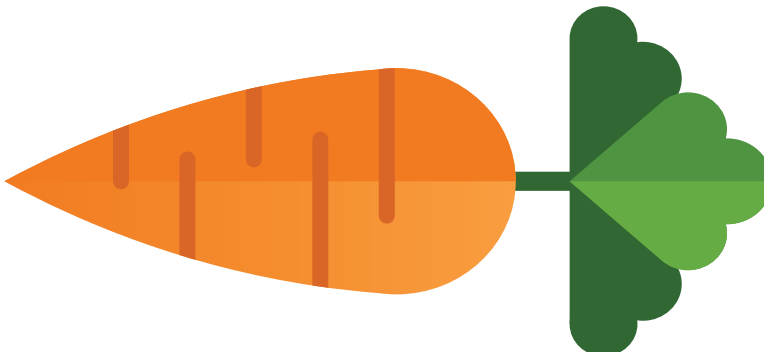

3

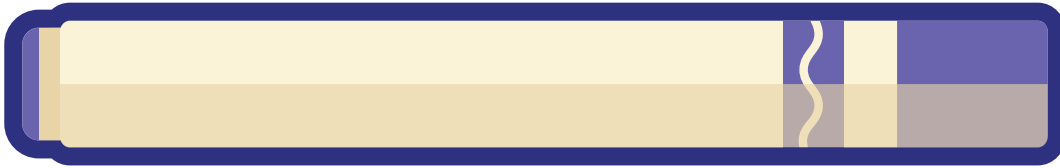

4



5



6

What is the length of the connecting cube tower in inches?

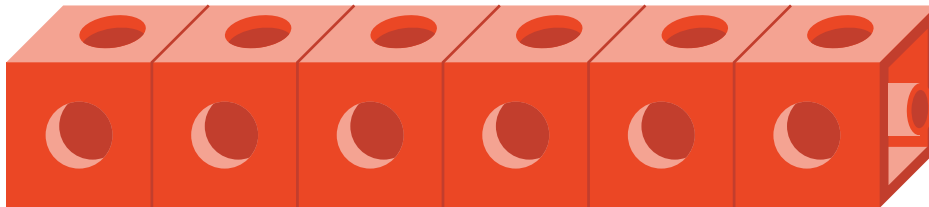

(A) $3\frac{1}{2}$ inches

(B) 4 inches

(C) $4\frac{1}{2}$ inches

(D) $5\frac{1}{2}$ inches

Spiral Review

For Problems 7–14, determine the value of the expression.

7 3×5 _____

8 4×7 _____

9 2×8 _____

10 5×10 _____

11 7×7 _____

12 3×9 _____

13 9×5 _____

14 6×5 _____

- 15 Determine the sum.
 $308 + 595$

 Show your thinking.

answer: _____

More Precise Measurements

Let's measure length in fourths of an inch.

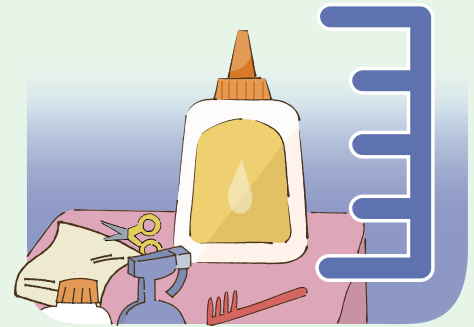

Warm-Up



 eyes on teacher



I am a doer of math.

What common mistakes could be made when using a ruler to measure length?

Activity

1

Partitioning Inches Into Fourths

Hands-On 

You will be given a paper inch ruler.

- 1 Partition every inch on the ruler into fourths of an inch.

1**Partitioning Inches Into Fourths (continued)**

- 2** Use the ruler to measure the lengths of 5 objects around the room. Record the object and its length.

Object	Length (in.)

- 3** **Discuss** 

How is measuring in quarter inches similar to and different from measuring in half inches?

Introducing the Center, Target Measurements

Stage 3



Pairs  Let's draw line segments to a quarter of an inch.

You'll need: ruler (inches), straightedge, Recording Sheet



How to Play

- 1 Player A:** Choose a target length in quarter inches, up to 8 inches, and record it.
- 2 Player A:** Begin to slowly draw a line with a straightedge on the Recording Sheet.
- 3 Player B:** Say, "Stop!" when you think the length of the line is equal to the target measurement.
- 4 Player B:** Measure the line segment to the nearest quarter inch. Record the measurement.
- 5** Determine the difference between the length of the line and the target measurement in quarter inches. The difference is Player B's score for the round.
- 6** Switch roles and take turns until each player's Recording Sheet is full.



How to Win The player with the lower score wins.

Target Measurements (continued)

			1	2	3	4
	Target:	Actual:	Points:			
	Target:	Actual:	Points:			
	Target:	Actual:	Points:			
Total Points:			_____			

Summary 6.03

You can measure length in fourths of an inch. When you measure length to the nearest fourth of an inch, you can use the quarter-inch, half-inch, and whole-inch marks on a ruler.

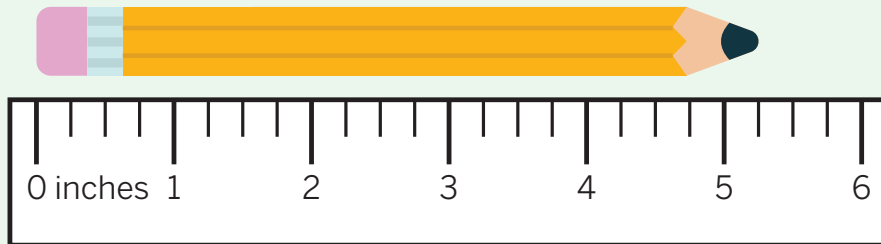

Practice 6.03

For Problems 1 and 2, measure the length of the arrow to the nearest fourth of an inch using your paper inch ruler.

1

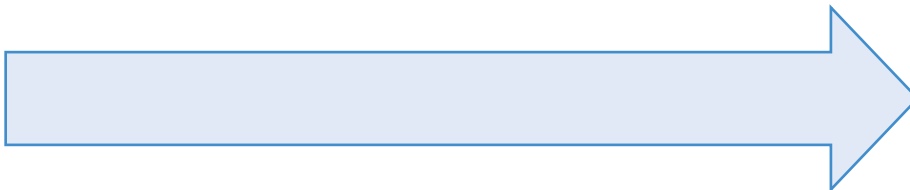

2

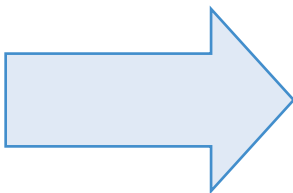

For Problems 3 and 4, draw a rectangle with the given length.

 **Draw**

3 $3\frac{1}{4}$ inches

4 $4\frac{2}{4}$ inches

5 Partition the ruler into fourths of an inch. What is the length of the rectangle?

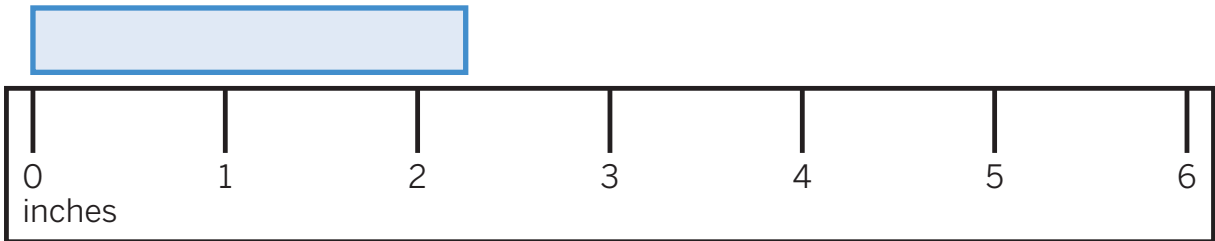

6  Partition the ruler into fourths of an inch. What is the length of the rectangle?

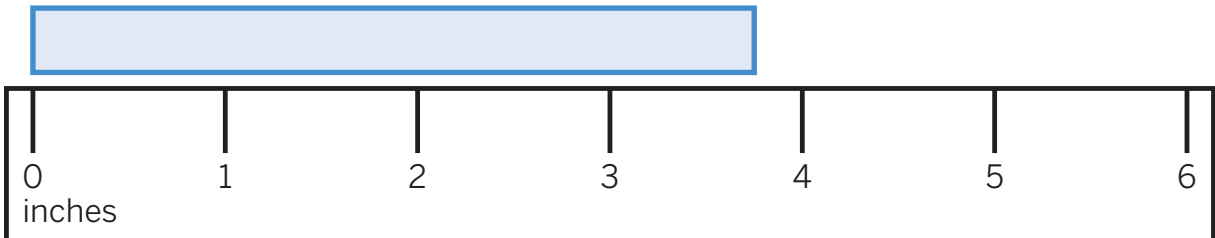

- (A) $3\frac{1}{4}$ inches (B) $3\frac{2}{4}$ inches (C) $3\frac{3}{4}$ inches (D) 4 inches

Spiral Review

For Problems 7–14, determine the value of the expression.

7 8×7 _____

8 6×9 _____

9 3×12 _____

10 4×4 _____

11 2×2 _____

12 3×8 _____

13 5×5 _____

14 6×6 _____

15 Determine the difference.
 $350 - 127$

 Show your thinking.

answer: _____

Same Lengths, Different Names

Let's measure length in whole, half, and quarter inches.

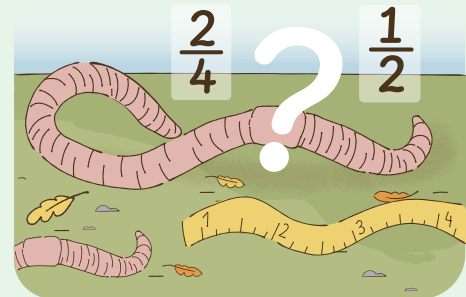

Warm-Up



eyes on teacher



I am a doer of math.

What do you do to check your work in math class?

Activity

1

Same Location

Mrs. Wilson and Sasha measure the lengths of worms because Mrs. Wilson says that the longer and juicier the worms, the better the worms are as food for chickens.

They discuss the length of a worm they picked.

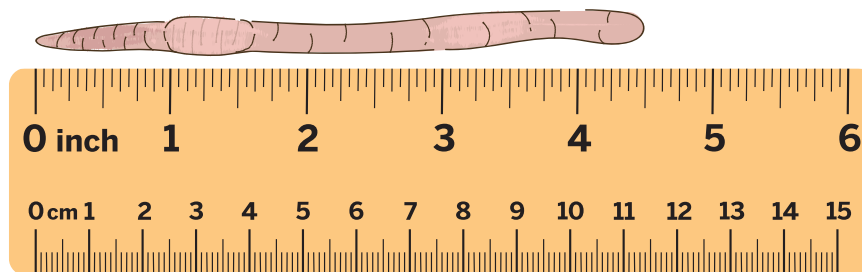

- Mrs. Wilson says that the worm is $4\frac{2}{4}$ inches long.
- Sasha says that the worm is $4\frac{1}{2}$ inches long.

1

Discuss

Who do you agree with? Why?

1**Same Location (continued)**

Measure the length of each worm. Then trade books with your partner and write a length that is equivalent to your partner's length.

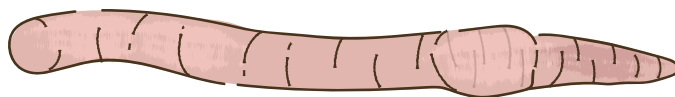
2

length: _____ equivalent length: _____

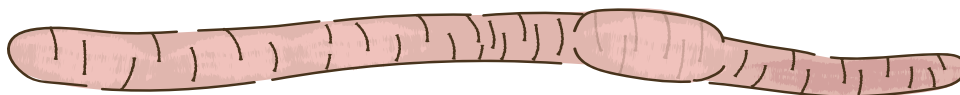
3

length: _____ equivalent length: _____

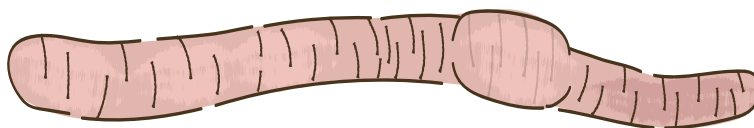
4

length: _____ equivalent length: _____



2

Whole, Half, and Quarter Inches

You will be given a standard inch ruler.

Measure each worm to the nearest whole inch, the nearest half inch, and the nearest quarter inch. Record your measurements as whole numbers or mixed numbers.

5

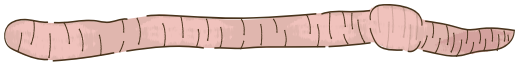

nearest whole inch: _____

nearest half inch: _____

nearest quarter inch: _____

6

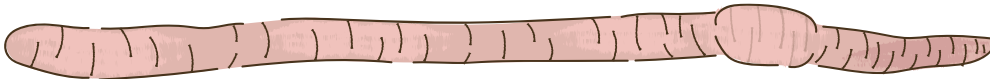

nearest whole inch: _____

nearest half inch: _____

nearest quarter inch: _____

Whole, Half, and Quarter Inches (continued)

7

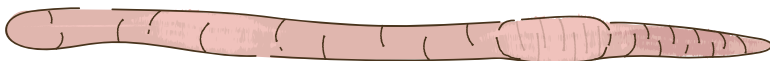

nearest whole inch: _____

nearest half inch: _____

nearest quarter inch: _____

8

Discuss 

Why can the measurement differ depending on whether you are measuring to the nearest whole, half, or quarter inch?



Summary 6.04

Describing length using the smallest unit is often more precise. The length of an object can be described in more than 1 way using equivalent fractions.

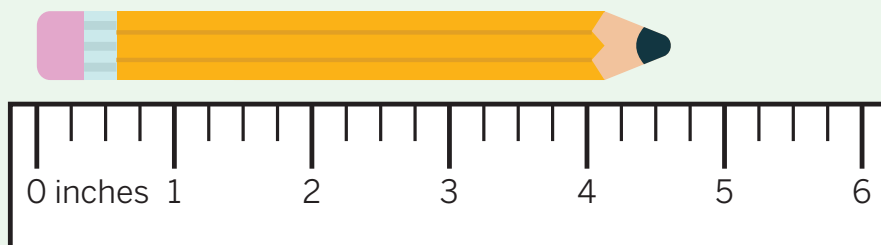

nearest
whole inch: 5

nearest
half inch: $4\frac{1}{2}$ or $4\frac{2}{4}$

nearest
quarter inch: $4\frac{3}{4}$

Practice 6.04

- 1 The lengths of 4 different rectangles are shown in inches.

$$3\frac{2}{4}$$

$$\frac{6}{2}$$

$$3\frac{1}{2}$$

$$3\frac{3}{4}$$

Which lengths are equivalent? Explain your thinking.

2 Which lengths are the same length? Select *all* that apply.

(A) $\frac{5}{2}$

(B) $5\frac{1}{2}$

(C) $2\frac{3}{4}$

(D) $2\frac{1}{2}$

(E) 3

(F) $2\frac{2}{4}$

For Problems 3 and 4, use a standard inch ruler to measure the length of the rectangle. Then write an equivalent length.

3

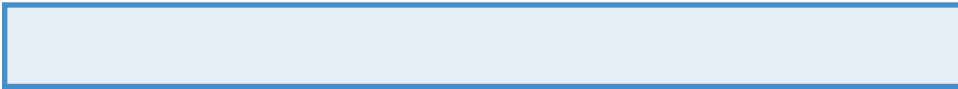

length: _____

equivalent length: _____

4

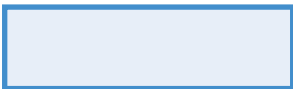

length: _____

equivalent length: _____

Spiral Review

For Problems 5–12, determine the value of the expression.

5 3×3 _____

6 8×8 _____

7 5×5 _____

8 10×7 _____

9 2×9 _____

10 7×3 _____

11 6×6 _____

12 1×3 _____

- 13 Complete the table by rounding each number to the nearest hundred and nearest ten.

Number	Nearest hundred	Nearest ten
158		
362		
408		
9		
51		

The Plot Chickens

Let's represent length measurement data in half and quarter inches on line plots.



Warm-Up

1

eyes on teacher

I am a doer of math.

How can working with others help you learn from mistakes you make in math class?

Activity

1

Mrs. Wilson's Chicken Coop

2

Create a line plot to represent the measurement data.

Chick Heights (in.)	
$6\frac{1}{2}$	$5\frac{3}{4}$
6	$5\frac{1}{4}$
$6\frac{1}{2}$	$6\frac{1}{2}$
$5\frac{3}{4}$	7

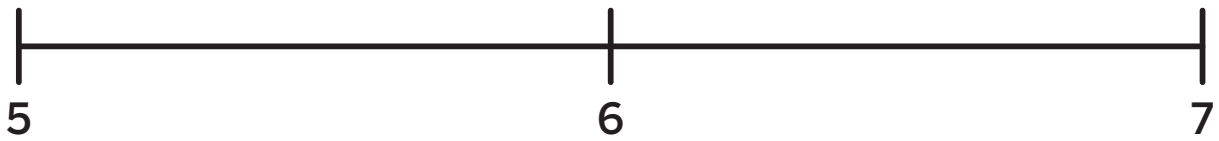
1**Mrs. Wilson's Chicken Coop (continued)** Draw**2****Explain** 

How did you represent the data?

3

Let's look at a line plot.

Chicks at the Fair

4 Justify

How do you know the statements about the data on the line plot are true?

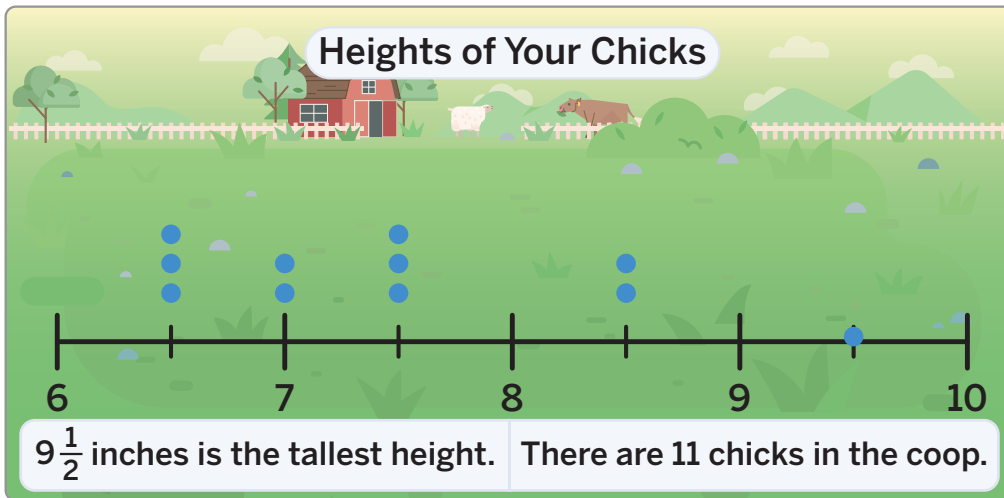

For Screens 5–7, create a line plot that makes all the statements true.

Draw

5

Heights of Rhode Island Red Chicks

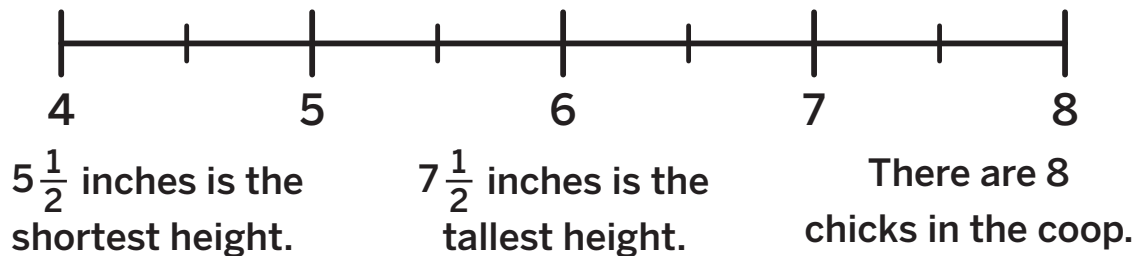

Chicks at the Fair (continued)

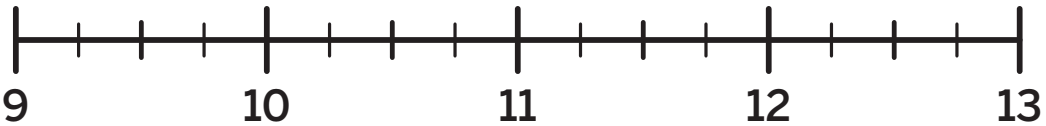
 Draw
6**Heights of Jersey Giant Chicks**

6 chicks are taller
than $10\frac{1}{2}$ inches.

12 inches is the
tallest height.

$11\frac{1}{4}$ is the most
common height.

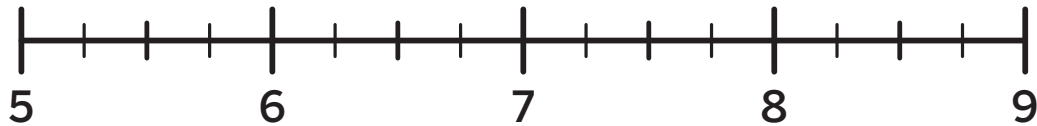
7**Heights of Silkie Chicks**

7 chicks are shorter
than 8 inches.

$7\frac{2}{4}$ inches is the
most common height.

$6\frac{1}{2}$ inches is the
shortest height.

Summary 6.05

Line plots can show length measurement data in whole, half, and quarter inches.

Heights of Mrs. Wilson's Chicks

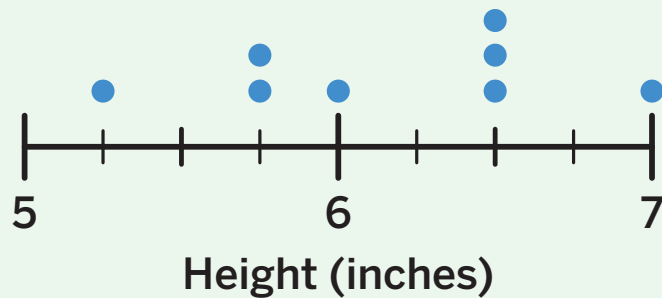

Chick Heights
(in.)

$6\frac{1}{2}$	$5\frac{3}{4}$
6	$5\frac{1}{4}$
$6\frac{1}{2}$	$6\frac{1}{2}$
$5\frac{3}{4}$	7

Practice 6.05

- 1 Use the line plot to determine which statement is true.

Tomato Lengths

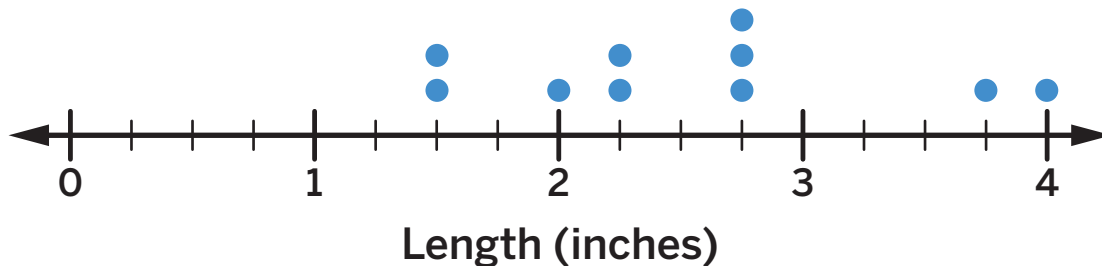

- (A) The largest tomato is $2\frac{3}{4}$ inches long.
- (B) 5 tomatoes are longer than $2\frac{3}{4}$ inches.
- (C) The smallest tomato is $2\frac{3}{4}$ inches long.
- (D) The most common tomato length is $2\frac{3}{4}$ inches.

The line plot shows the lengths of some postcards in inches. Use the line plot for Problems 2–4.

Postcard Lengths

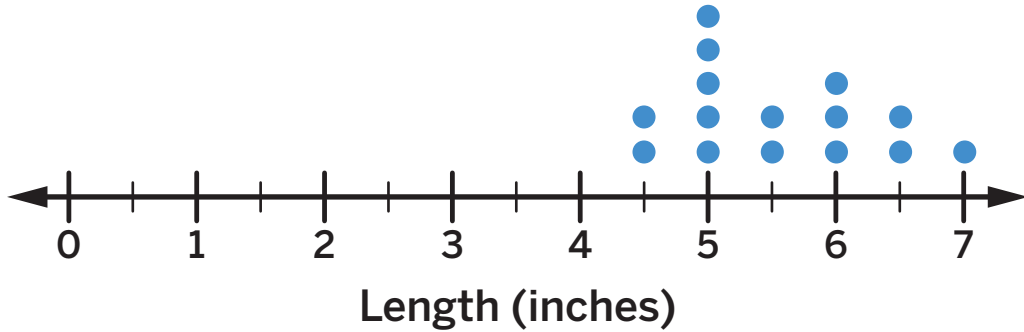

2 How many postcards measured $5\frac{1}{2}$ inches long?

3 How many postcards measured 6 inches or longer?

4 How many postcards were measured for the line plot?

5 The lengths of some ribbons are shown in inches. Represent the data on the line plot.

$6\frac{1}{2}$ 6 $5\frac{1}{2}$ $6\frac{1}{2}$ $7\frac{1}{4}$ 9 $8\frac{1}{2}$ $7\frac{3}{4}$

Ribbon Lengths

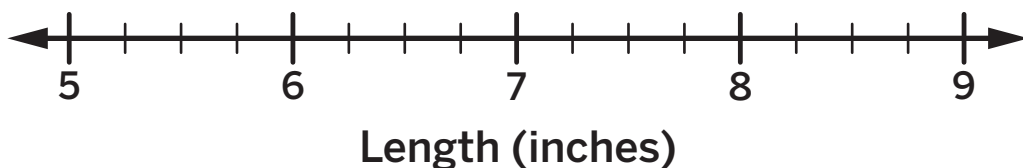

Spiral Review

For Problems 6–13, determine the value of the expression.

6 2×2 _____

7 2×6 _____

8 8×3 _____

9 3×5 _____

10 4×4 _____

11 2×4 _____

12 5×10 _____

13 6×5 _____

14 Determine the sum.

$$564 + 285$$

 Show your thinking.

answer: _____

Let's Make a Line Plot

Let's collect measurement data and represent data on a line plot.

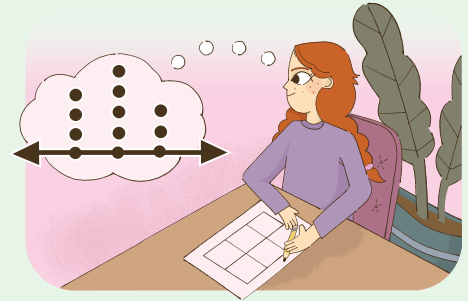

Warm-Up



eyes on teacher



I am a doer of math.

What mistake have you made that helped you learn something important in math class?

Activity

1

Going on a Measurement Walk

Your group will be given an inch ruler.

- 1 Decide with your group what type of objects you will measure. As a group, you will measure 10 objects in total.
- 2 Measure the objects to the nearest half or quarter inch and record the lengths in the tables.

Length (in.)

Length (in.)

3 Data Talk!

What do you notice and wonder about your group's data?

Let's Make a Line Plot

You and your group will create a line plot to represent the measurement data you collected. Discuss your plan as a group and use the blank line plot for your draft. Then create a visual display to share your line plot with the class.

4 Data Talk!

- What scale will you use and why?
 - How will you label the tick marks so that all the measurements are included?
 - How will you include half and quarter inch measurements?
- What details will you include to help others understand the data you collected?

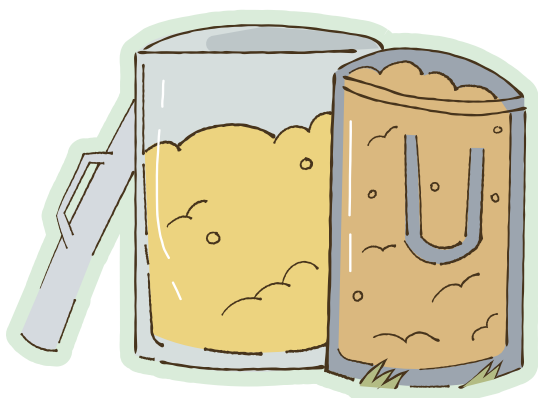

Summary 6.06

Length measurement data can be displayed on a line plot that shows fractions of an inch. The scale of the line plot can be chosen based on the data.

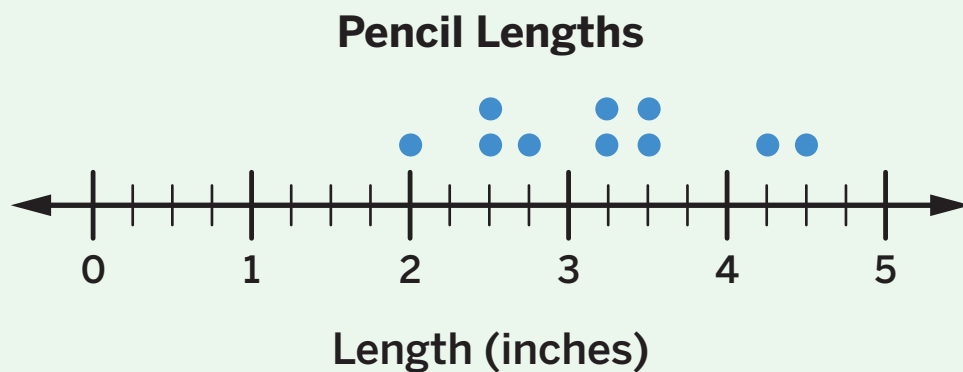

Practice 6.06

- 1  The lengths of some straws are shown in inches. Represent the data on a line plot.

$4\frac{3}{4}$ $5\frac{1}{2}$ $4\frac{1}{4}$ $5\frac{2}{4}$ $4\frac{1}{2}$ $3\frac{3}{4}$ $5\frac{1}{4}$ $4\frac{2}{4}$ 5 $4\frac{1}{4}$ $4\frac{1}{2}$

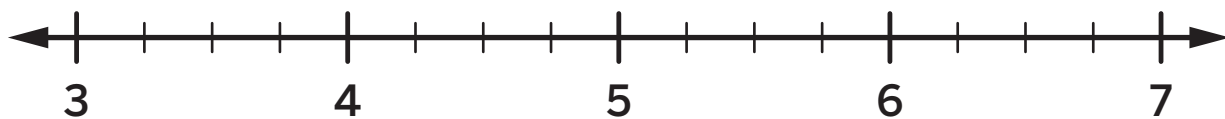

- 2**  The lengths of some feathers from Sasha's chick are shown in inches. Represent the data on a line plot.

$2\frac{1}{4}$ $1\frac{3}{4}$ $\frac{4}{2}$ $\frac{2}{1}$ $1\frac{1}{2}$ $2\frac{3}{4}$ 2 $2\frac{1}{4}$ $1\frac{1}{2}$ $1\frac{2}{4}$ $1\frac{2}{4}$



- 3** Create a line plot that matches the statements.

- The line plot shows the lengths of 10 rectangles.
- The shortest rectangle has a length of $5\frac{1}{4}$ inches.
- The longest rectangle has a length of 9 inches.
- 6 of the rectangles are longer than $7\frac{2}{4}$ inches.
- $8\frac{1}{2}$ inches is the most common rectangle length.



Spiral Review

For Problems 4–11, determine the value of the expression.

4 1×8 _____

5 9×2 _____

6 3×4 _____

7 4×10 _____

8 8×5 _____

9 6×3 _____

10 5×7 _____

11 8×9 _____

For Problems 12 and 13, locate and label the pair of fractions on the same number line.

12 $\frac{3}{2}$ and $1\frac{2}{4}$

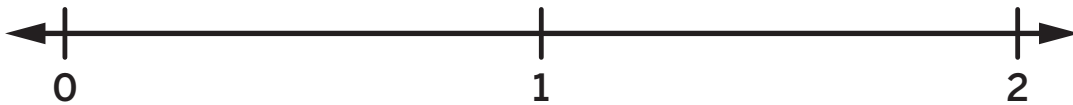

13 $\frac{4}{6}$ and $\frac{8}{6}$

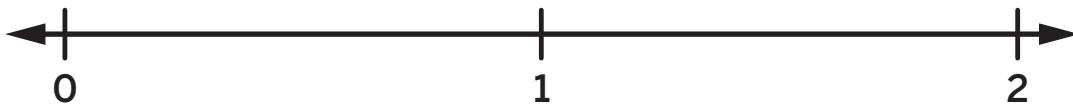

Weight and Liquid Volume

✦ Unit Story: Just Stick With It, Sasha



Vastram/Shutterstock.com

Sasha carefully measured the amount of water to give to Evelyn.

What are other situations where you might need to know how much liquid you are using?

Estimating Weight

Let's estimate weight.

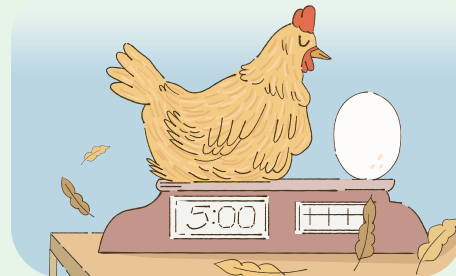

Warm-Up



eyes on teacher



I am a doer of math.

What do you do when you do not yet understand a new math idea?

Activity

1

Estimating Weight

Hands-On

A paper clip weighs about 1 gram (g). A basket of apples weighs about 1 kilogram (kg).



Lesia Kapinosova/Shutterstock.com

You will be given weights that are labeled with their weight measurements.

1**Estimating Weight (continued)**

- 1** What objects could be the same weight as each weight measurement?

1 gram	
10 grams	
100 grams	
1 kilogram	
2 kilograms	

- 2** Find classroom objects that could belong in each category based on their estimated weights.

Less than 1 gram	
Between 1 gram and 100 grams	
Between 100 grams and 1 kilogram	
More than 1 kilogram	

- 3** **Discuss** 

Choose 1 object with an estimated weight between 100 grams and 1 kilogram. Justify that your estimate is reasonable.

Introducing the Center, Estimate and Measure

Stage 6



Pairs  Let's estimate and measure the weights of different objects.

You'll need: balance, objects to measure, weights (grams), Recording Sheet



How to Play

- 1 Each partner chooses an object to measure that is about the size of your hand.
- 2 Each partner estimates the weight of their own object to the nearest gram and records their estimate.
Think: A small paper clip is about 1 gram.
- 3 **Player A:** Measure the weight of your object and record the weight under Object A.
- 4 **Player B:** Measure the weight of your object and record the weight under Object B.
- 5 Measure the weights of different objects until the Recording Sheet is full.



Discuss

- Which object has the greatest weight? The least weight?
- Do you notice any relationships between an object's size and its weight?
- How could you determine the difference in weight between two of your objects?

Estimate and Measure (continued)

<i>Think: A small paper clip is about 1 gram.</i>					
Object A	Object A estimate	Object A weight	Object B	Object B estimate	Object B weight
marker	70 grams	78 grams	pencil	30 grams	25 grams

Summary 6.07

You can use what you know about **grams** and **kilograms** to help estimate the **weight** of an object.



I know a paper clip is about 1 gram. The crayon feels heavier than 1 paper clip but lighter than 10 paper clips. I think the crayon weighs about 6 grams.



I know a basket of apples is about 1 kilogram. A laptop feels about as heavy as 2 baskets of apples. So, I think the laptop is about 2 kilograms.

gram A unit of weight in the metric measurement system (1,000 grams is equal to 1 kilogram)

kilogram A unit of weight in the metric measurement system (1 kilogram is equal to 1,000 grams)

Practice 6.07

- 1 Which 2 objects could have a weight of about 1 gram?

(A) a piece of gum (B) a chair

(C) a pen (D) a dollar bill
- 2 Which 2 objects could have a weight of about 1 kilogram?

(A) a stapler (B) a pineapple

(C) a rabbit (D) a packed suitcase

Practice 6.07

Name _____ Date _____

- 3** Select whether each item weighs *about 1 gram*, *about 100 grams*, or *about 1 kilogram*. Place a check mark in the correct column.

	About 1 gram	About 100 grams	About 1 kilogram
100 paper clips			
a thumbtack			
a stick of butter			
a cabbage			
a small button			
1,000 paper clips			
a lemon			
a bag of sugar			
an otter			
a raisin			
2 forks			
a yo-yo			

Spiral Review

For Problems 4–11, determine the value of the expression.

4 5×5 _____

5 7×7 _____

6 3×3 _____

7 9×9 _____

8 2×2 _____

9 6×6 _____

10 8×8 _____

11 4×4 _____

12 Determine the sum.

$$277 + 341$$

 Show your thinking.

answer: _____

Weight It Out

Let's measure and determine the weights of objects.



Warm-Up

1 eyes on teacher

I am a doer of math.

What are some things you could weigh? Why would you want to weigh them?

Activity

1

Weight and See

Hands-On

You will be given a balance and a set of weights.

- 2** Place an object on 1 side of the balance. Then add weights to the other side until both sides are the same weight.

Explain

How did you know that both sides of the balance are the same weight?

- 3** Replace the object on the balance with a new object. Then add weights to the other side until both sides are the same weight.

1**Weight and See (continued)****4****Describe** 

What do you notice about the weights of these animals?

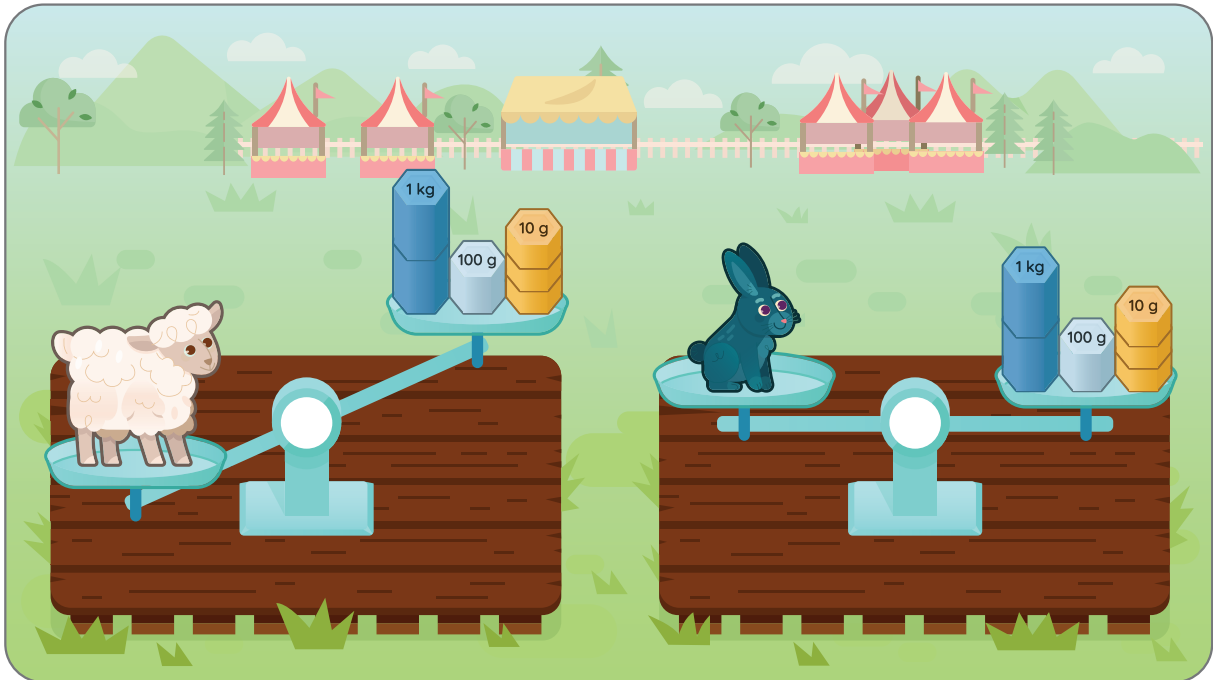

Weight's Over!

5 What is the weight of the sheep?

i Show your thinking.

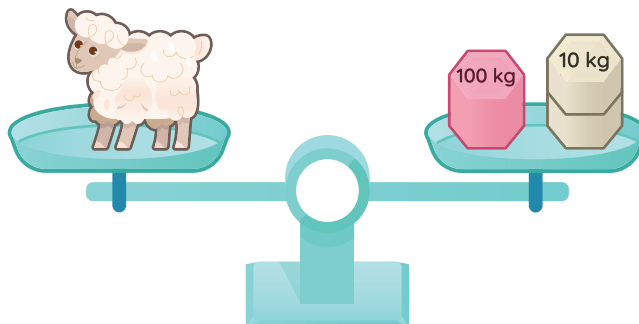

answer: _____

6 What is the weight of the mouse?

i Show your thinking.

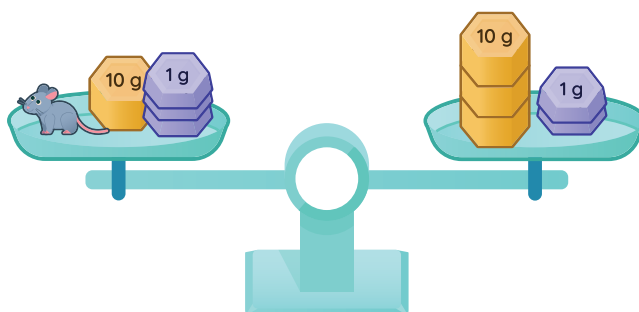

answer: _____

Weight's Over! (continued)

7 Each pig weighs the same. What is the weight of each pig?

i Show your thinking.

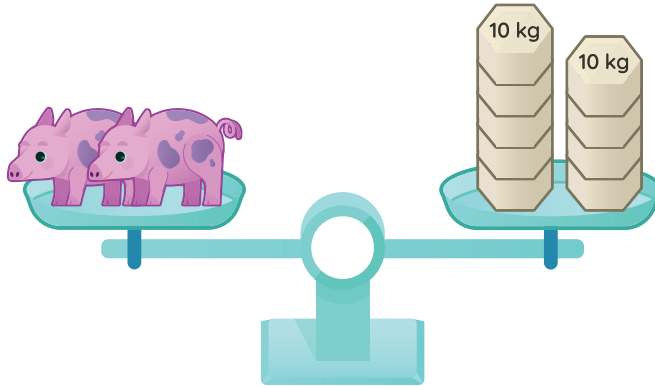

answer: _____

Explain

How did you determine the weight of each pig?

8 Each chick weighs the same. What is the weight of each chick?

i Show your thinking.

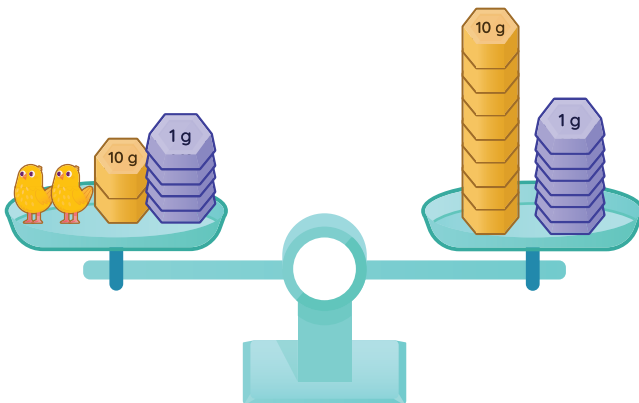

answer: _____

Summary 6.08

When a balance is level, the weight of the objects on both sides is the same. You can use what you know about leveled and unlevelled balances to solve problems involving weight.

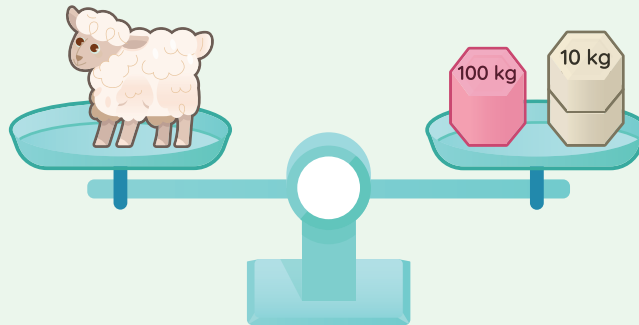

The sheep weighs 120 kilograms because the balance is level.

Practice 6.08

- 1  What is the weight of the hedgehog?

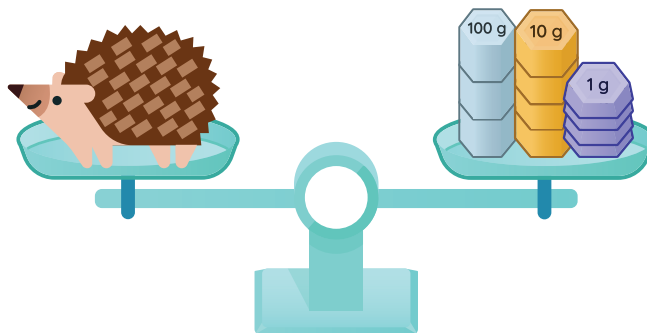

- 2 Select *all* the true statements about the animals on the balances. The same raccoon is shown on both balances.



- (A) The raccoon and the fox are the same weight.
(B) The raccoon is heavier than the fox.
(C) The weight of the fox is 9 kilograms.
(D) The weight of the raccoon is 9 kilograms.
(E) The fox weighs more than 9 kilograms.

- 3 Which 2 objects weigh more than 1 kilogram?

- (A) a watermelon (B) a dog
(C) an eraser (D) a picture book

- 4 Which 2 objects weigh less than 1 kilogram?

- (A) scissors (B) a cooking pan
(C) an apple (D) a full backpack

Practice 6.08

Name _____ Date _____

For Problems 5–12, determine the value of the expression.

5 8×9 _____

6 7×8 _____

7 3×6 _____

8 6×6 _____

9 10×8 _____

10 4×7 _____

11 9×2 _____

12 4×9 _____

Spiral Review**13** Determine the difference.

$675 - 381$

i Show your thinking.

answer: _____

Measuring Liquids

Let's measure amounts of liquids.

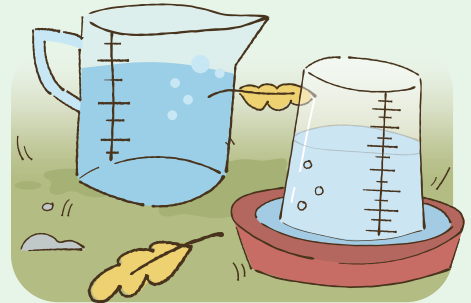

I am a doer of math.

How could Sasha make sure she is giving Evelyn enough water every day?

Warm-Up



eyes on teacher

Activity

1

How Much Is Enough?

Hands-On

Your group will be given 3 containers labeled A, B, and unit. Record an estimate that is *too low*, *about right*, and *too high* for each container.

1 How many units of liquid will Container A hold?

Too low	About right	Too high

2 How many units of liquid will Container B hold?

Too low	About right	Too high

1**How Much Is Enough? (continued)****3****Discuss** 

- Compare the amount of liquid that Containers A and B hold. Use the unit if it is helpful.
- Which container holds the greater amount of liquid? How do you know?

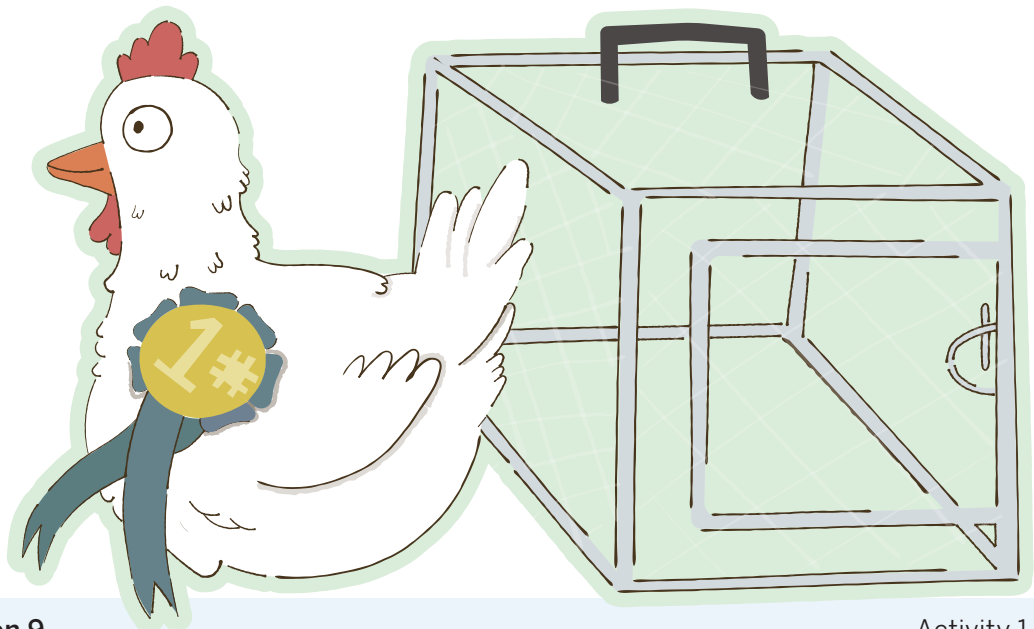

2

Water for Evelyn!

Hands-On 

Your group will be given a 1-liter container and a larger container.

- 4 How many **liters** (L) of water will fit in the larger container? Record an estimate that is *too low*, *about right*, and *too high*.

Too low	About right	Too high

5 Discuss 

How could you use the 1-liter container to help Sasha determine how many liters of water the larger container holds?

Water for Evelyn! (continued)

6 Discuss

Use your materials and water supply to determine how many liters of water your container holds. Explain how you know.



Summary 6.09

Liquid volume is the amount of space that a liquid takes up. A **liter** is one of the many standard units that can be used to measure liquid volume.



liquid volume The amount of space that a liquid takes up.
liter A liquid volume unit that is in the metric measurement system.

Practice 6.09

- 1 Select whether each container holds less than 1 liter of liquid or more than 1 liter of liquid.

	Less than 1 liter	More than 1 liter
a cooking pot		
a juice cup		
1 tablespoon		
a bath tub		

- 2 Which container holds about 1 liter of liquid?

- (A) a water bottle (B) a measuring spoon
(C) a sink (D) a toilet tank

Practice 6.09

Name _____ Date _____

For Problems 3–11, decide whether the container holds *more than 1 liter*, *less than 1 liter*, or *about 1 liter* of liquid.

3 a bathtub

4 a spoon

5 a swimming pool

6 a small pot for a plant

7 a can of sparkling water

8 a gas tank

9 a lake

10 a fountain drink

11 a soup ladle

Spiral Review

For Problems 12–19, determine the value of the expression.

12 9×2 _____

13 4×3 _____

14 5×1 _____

15 2×6 _____

16 4×4 _____

17 3×10 _____

18 8×3 _____

19 2×3 _____

20 Determine the difference.

$$608 - 461$$

 Show your thinking.

answer: _____

How Much Liquid Does It Hold?

Let's measure and estimate liquid volume.

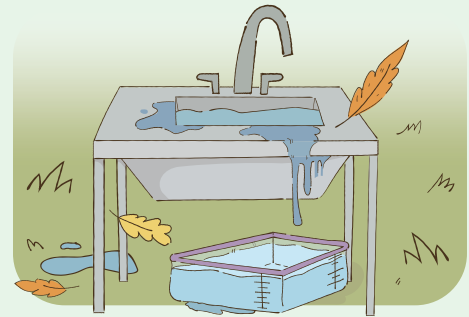

Warm-Up



eyes on teacher



I am a doer of math.

Sasha made mistakes when caring for Evelyn. How does making mistakes in math class help you grow?

Activity

1

Estimating Liquid Volume

Clare says the bathtub can hold a total of about 2 liters.
Jada says the bathtub can hold a total of about 20 liters.
Diego says the bathtub can hold a total of about 200 liters.



ben bryant/Shutterstock.com

1

Discuss

Who is correct? Justify your thinking.

1

Estimating Liquid Volume (continued)

Use the number of liters to estimate how many total liters each container can hold.

Number of liters

500 liters

10 liters

50 liters

2 liters

2 a bottle



Jacob Kearns/Shutterstock.com

answer: _____

3 a kiddie pool



Rianna M. Hill/Shutterstock.com

answer: _____

4 a pot



Mirror-Images/Shutterstock.com

answer: _____

5 a sink



David Papazian/Shutterstock.com

answer: _____

Measuring Liquid Volume

The containers are marked in liters. Determine the volume of the liquid in each container.

6

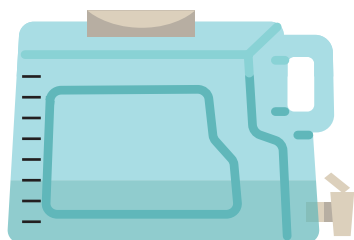

7

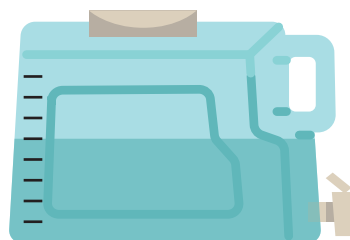

8

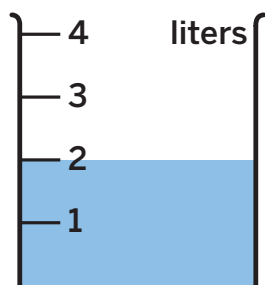

9

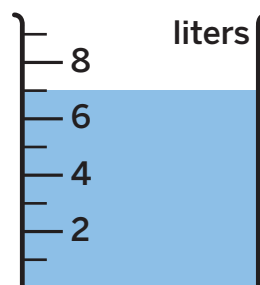

10

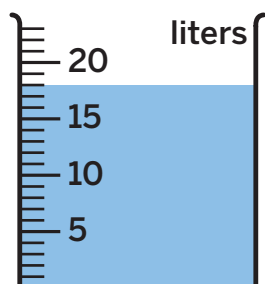

11

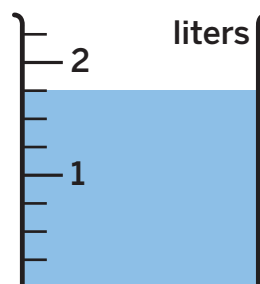

Measuring Liquid Volume (continued)

Shade each empty container to represent the liquid volume.

 Draw

12 1 liter

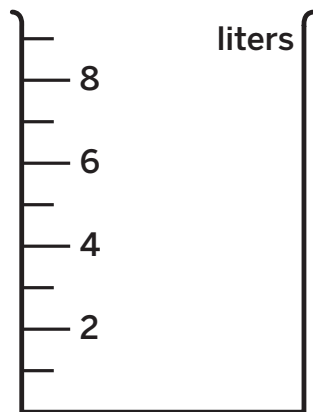

13 8 liters

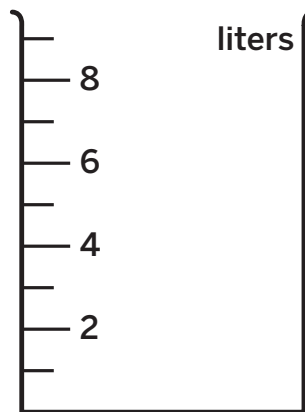

14 14 liters

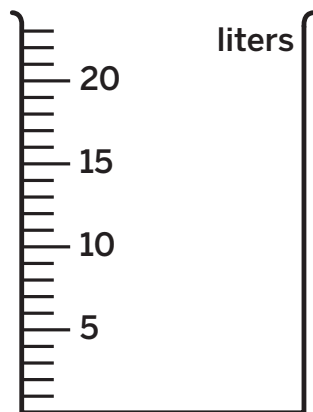

15 $2\frac{1}{2}$ liters

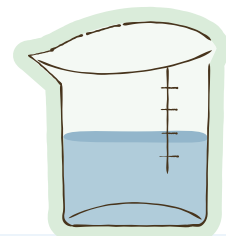
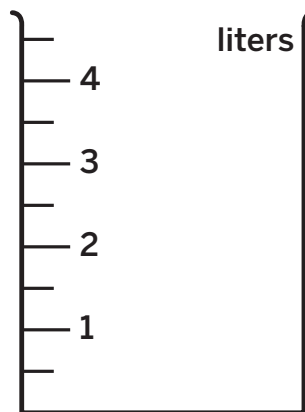

Summary 6.10

You can use your understanding of 1 liter or other known volumes to estimate and measure liquid volume in whole liters or fractions of a liter.

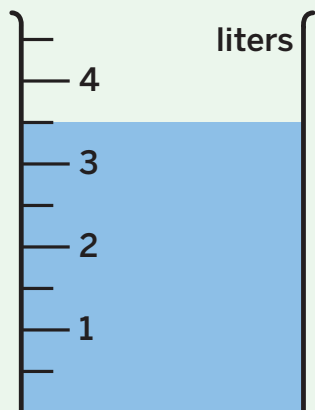

The liquid volume is $3\frac{1}{2}$ liters because it is halfway between 3 and 4 liters.

Practice 6.10

For Problems 1 and 2, determine the volume of liquid shown in the container. The containers are marked in liters.

1

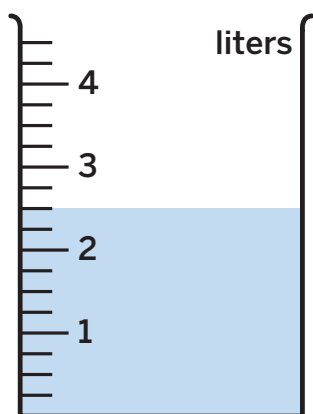

answer: _____

2

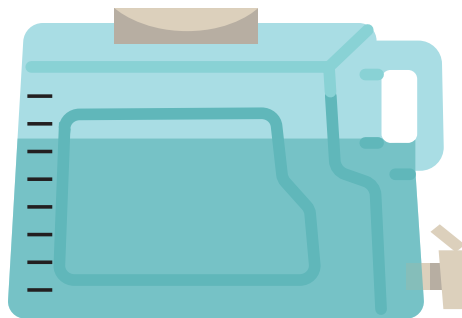

answer: _____

Practice 6.10

Name _____ Date _____

For Problems 3 and 4, shade the empty container to represent the liquid volume. The containers are marked in liters.

3 $1\frac{3}{4}$ liters

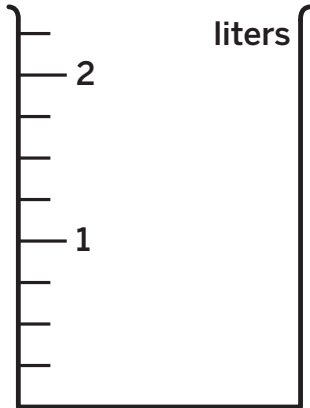

4 4 liters

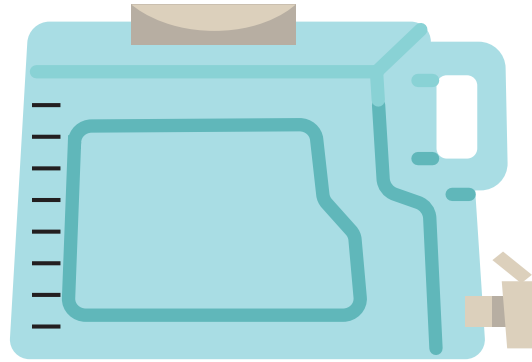

5 Which container has a liquid volume of $3\frac{1}{4}$ liters?

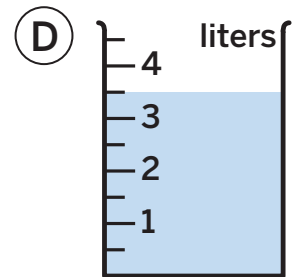
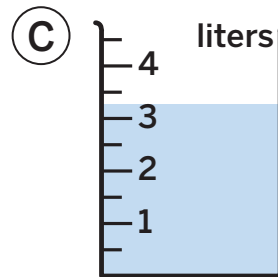
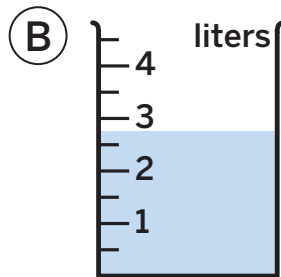
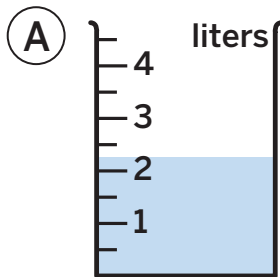

6 Which container has a liquid volume of 5 liters?

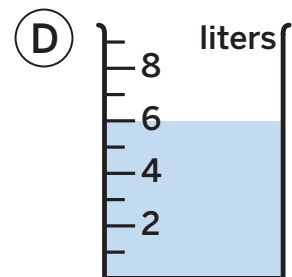
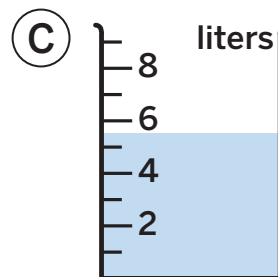
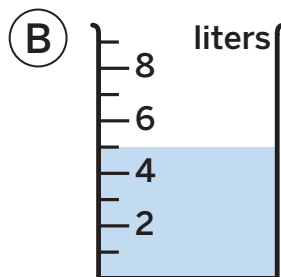
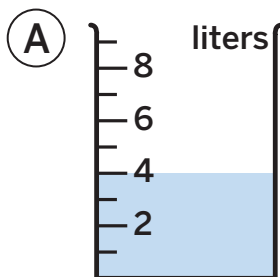

Spiral Review

For Problems 7–14, determine the value of the expression.

7 7×2 _____

8 3×8 _____

9 2×5 _____

10 10×2 _____

11 6×3 _____

12 5×4 _____

13 1×10 _____

14 9×3 _____

For Problems 15 and 16, locate 1 on the number line and label it with a whole number and a fraction.

i Show your thinking.



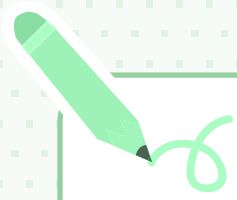

Notes:

Problems Involving Time

✦ Unit Story: Just Stick With It, Sasha

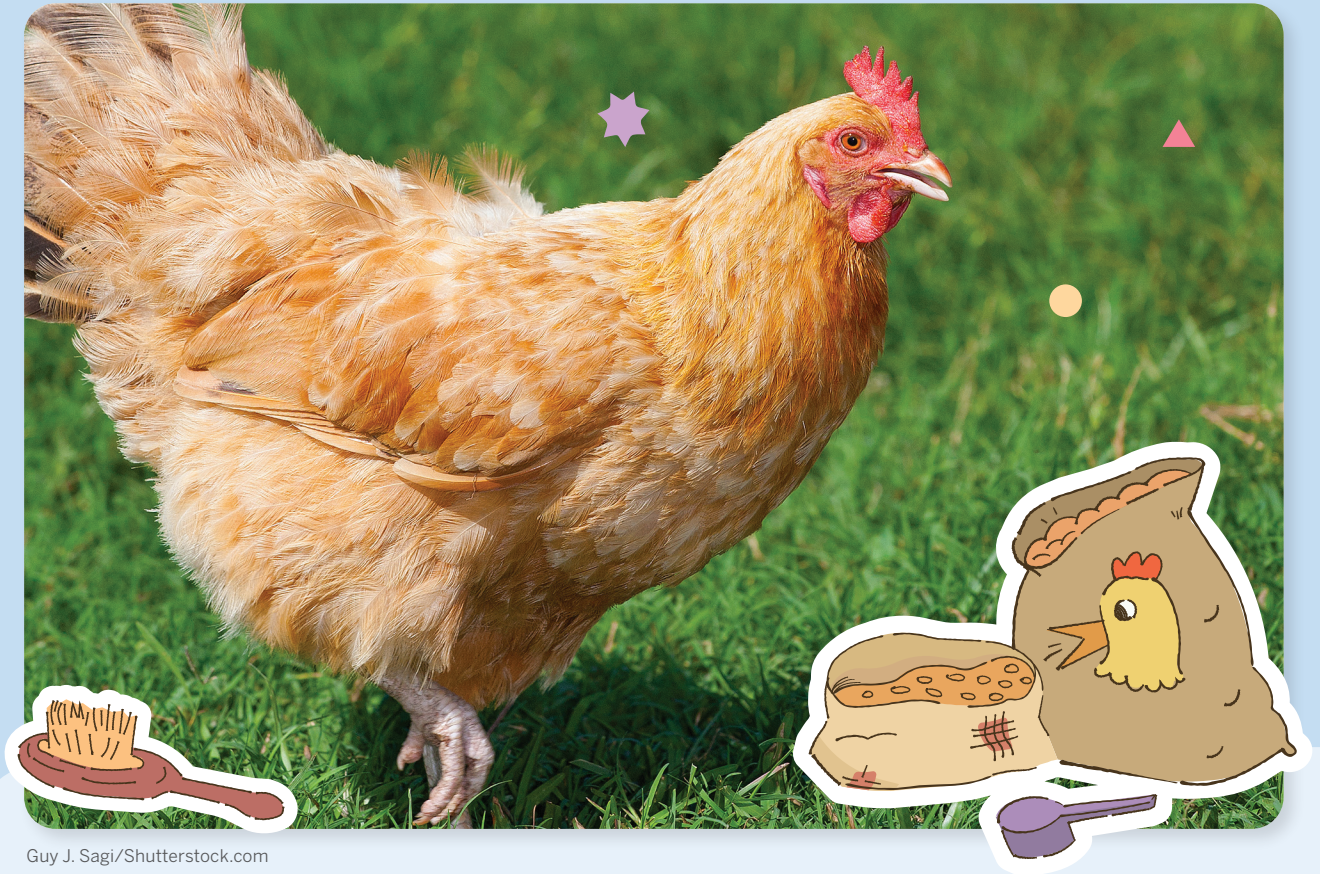

Guy J. Sagi/Shutterstock.com

Sasha spent a lot of time caring for Evelyn.

How much time do you spend each day on a hobby you enjoy?

Hands of Time

Let's tell and write time to the minute.



Warm-Up

1  eyes on teacher

I am a doer of math.
When have you needed to make a schedule like Sasha?

Activity

1 Minute Mastery

2 Sasha will wake up at 6:24 a.m. Draw the hands on the clock to show the time Sasha will wake up.

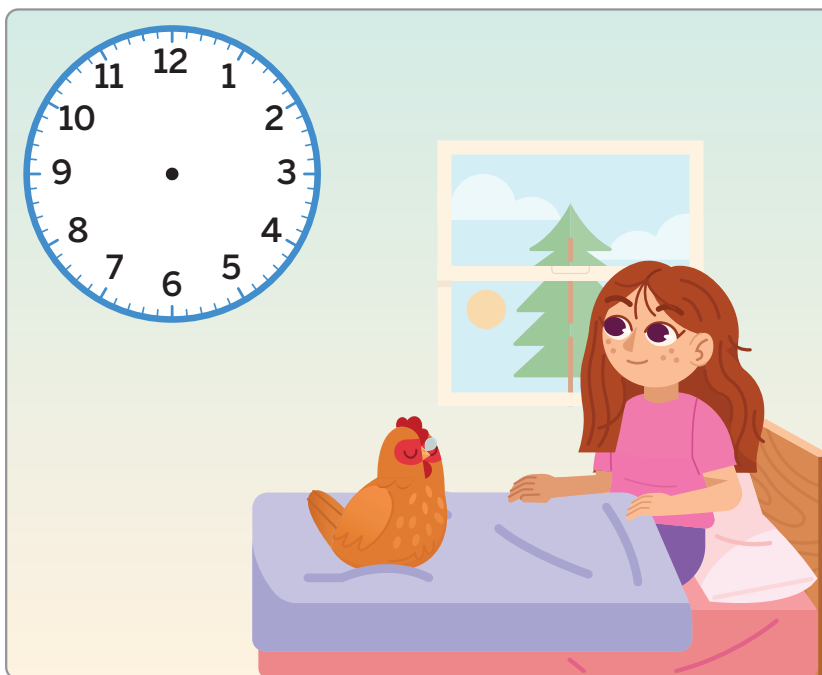

1

Minute Mastery (continued)

3 Design a Challenge

- Use the *Design a Challenge* sheet to choose a daily activity for Sasha and Evelyn and write a time for the activity.
- Represent the time you chose on the clock.
- Trade your *Design a Challenge* sheet with a partner.
- Record your partner's time and draw the hands on the clock to show the time.
- Repeat with a new partner.

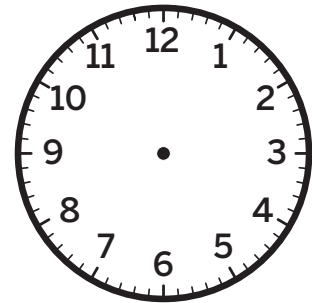

- 3** Record your partner's time and draw the hands on the clock to show the time. Complete as many challenges as you have time for.

Challenge 1

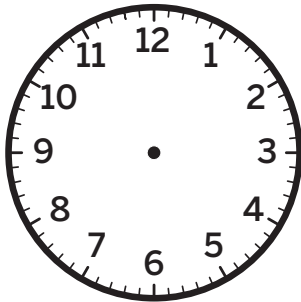

Challenge 2

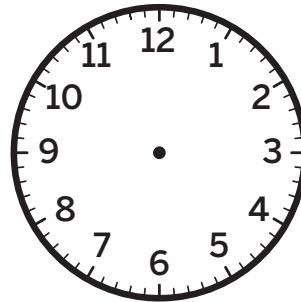

Challenge 3

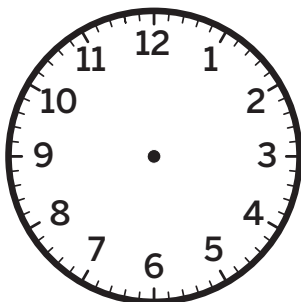

Challenge 4

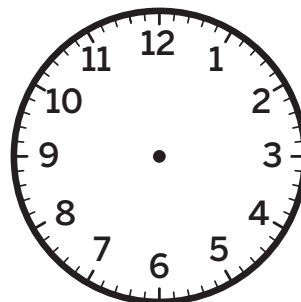

2**Two Hands, One Clock**

- 4** Draw the hands on the clock to show 5:58 so Sasha knows what time to be prepared for dinner with Mrs. Wilson.

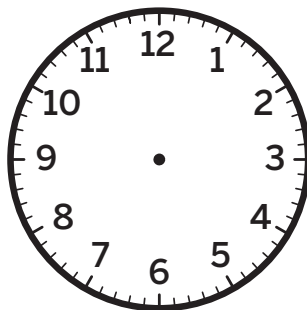

Explain how you know that the clock shows 5:58.

Two Hands, One Clock (continued)

5

Sasha keeps checking the clock to see if it is time for dinner with Mrs. Wilson. Write the time shown on each clock.

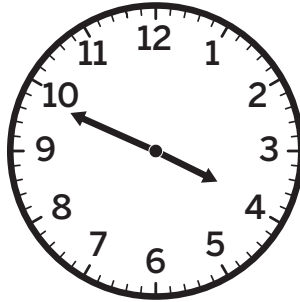

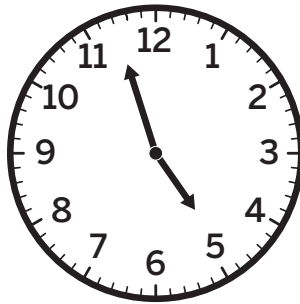

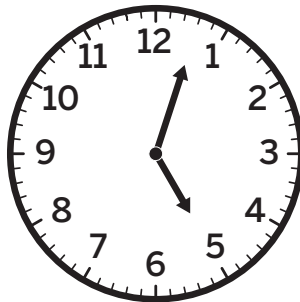

Discuss 

What is similar and different about the positions of the hands?

6

Let's discuss how the hour hand and minute hand are related.

Summary 6.11

Each tick mark around the clock represents 1 minute. The hour hand reaches the next hour when the minute hand reaches 60 minutes. Understanding the structure of the clock and how the hands move can be helpful when determining a strategy to tell time.

Count on from 5:00

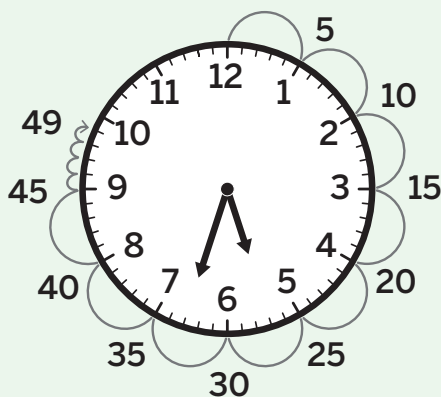

Count back from 6:00

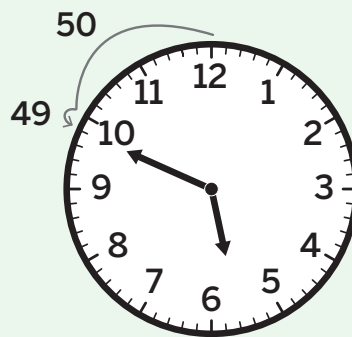

Practice 6.11

1 Which clock shows 10:57?

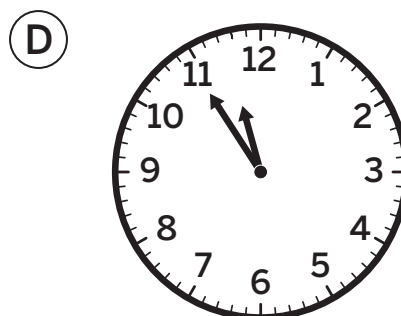
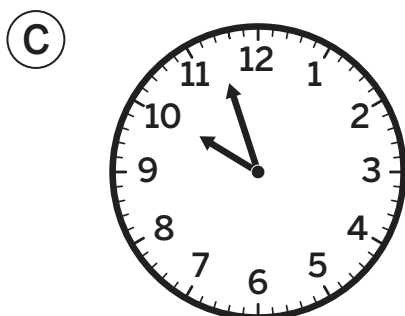
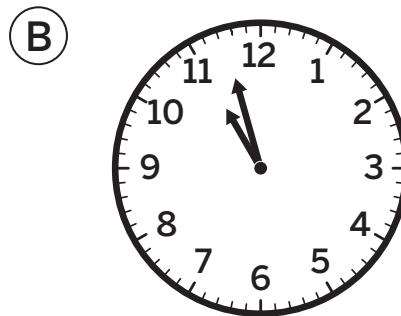
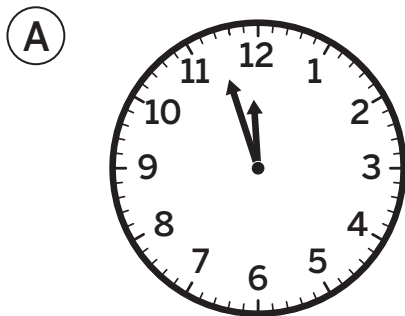

2  What time is shown on the clock?

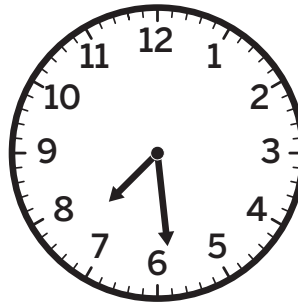

For Problems 3–6, write the time shown on the clock.

3

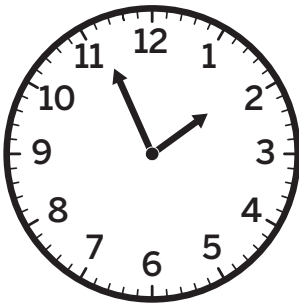

4

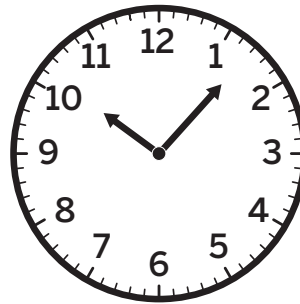

5

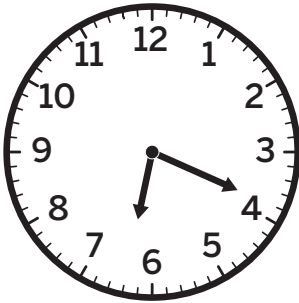

6

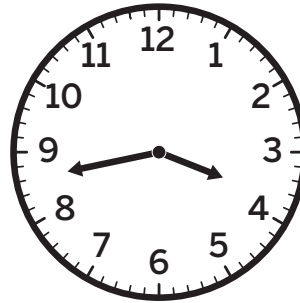

7

Diego drew the hands on the clock and wrote the time 1:00. Did Diego write the correct time? Explain your thinking.



Spiral Review

For Problems 8–11, determine the value of the expression.

8 5×5 _____

9 7×7 _____

10 3×3 _____

11 9×9 _____

12 Here are some clues about a mystery number.

- The number is odd.
- To the nearest hundred, the number rounds to 300.
- To the nearest ten, the number rounds to 320.

Write *all* the numbers that the mystery number could be.

13 Jada thinks of a mystery number and gives these clues.

- The number is even.
- The number rounded to the nearest ten is 670.
- The number is between 660 and 680.

Write *all* the numbers that the mystery number could be.

Chicken Time

Let's determine the times that activities start or end.

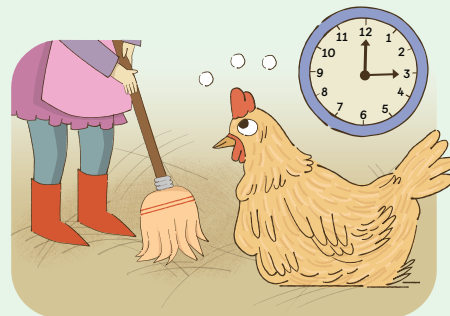

Warm-Up



eyes on teacher



I am a doer of math.

What mistakes did you make today that made you a better time-teller?

Activity

1

Cleaning the Coop

- Shade each of the clocks to match the fraction of time shown in the table. Write the number of minutes that corresponds with each fraction.

quarter past	half hour	quarter to
_____ minutes	_____ minutes	_____ minutes

2 Discuss

Which fraction of time represents the largest amount of time?
Which fraction represents the smallest amount of time?
How do you know?

1

Cleaning the Coop (continued)

Solve the time problems. You can use the clocks if it is helpful.

- 3 Sasha got to Evelyn's coop at 7:27 a.m. It took her a quarter of an hour to clean Evelyn's coop. What time did she finish cleaning the coop?

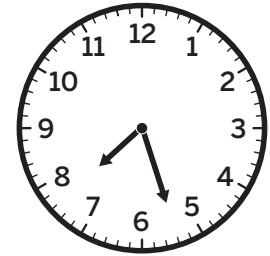

i Show or explain your thinking.

answer: _____

- 4 Sasha finished cleaning Evelyn's coop at a quarter after 7. It took her 32 minutes to clean the coop. What time did Sasha begin cleaning the coop?

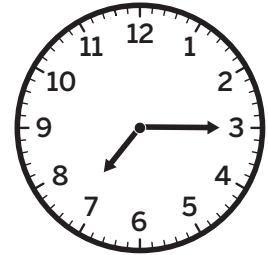

i Show or explain your thinking.

answer: _____

- 5 Discuss 

What was similar and different about Problems 3 and 4?

Cleaning Evelyn

Solve the time problems. You can use the blank clocks if it is helpful.

- 6 It took Sasha 28 minutes to clean Evelyn.
She began cleaning Evelyn at 3:46.
What time did Sasha finish cleaning Evelyn?

i Show or explain your thinking.

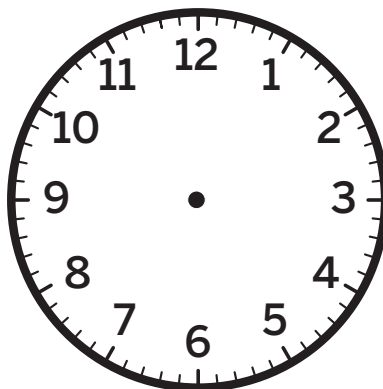

answer: _____

Cleaning Evelyn (continued)

7 It took Sasha 28 minutes to clean Evelyn.

She finished cleaning Evelyn at 6:09.

What time did Sasha begin cleaning Evelyn?

i Show or explain your thinking.

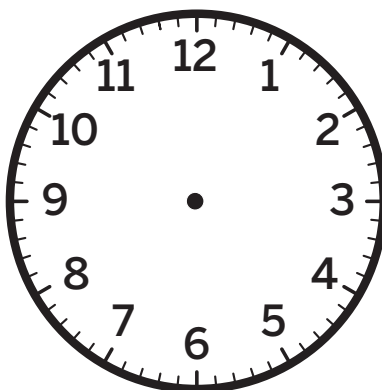

answer: _____

Summary 6.12

When solving problems about time, you can count on or back to determine an unknown end time or start time. Sometimes when counting on or back, you will need to cross the hour. You can use quarter and half hours to help represent time on clocks or in fractional units.

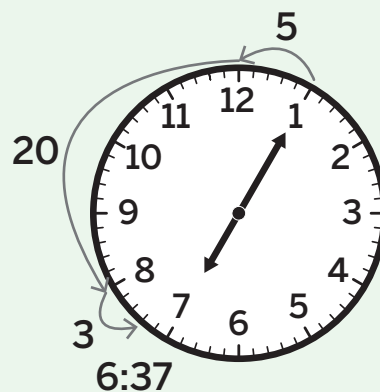
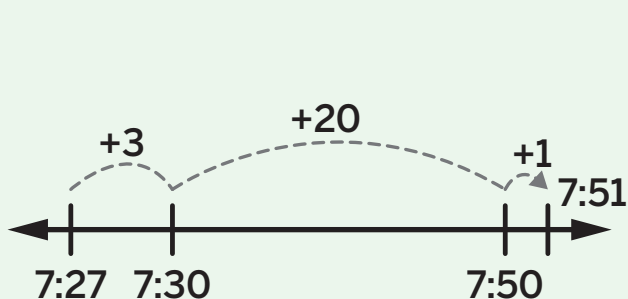

Practice 6.12

- 1 It took Jada 24 minutes to walk her dog. She began her walk at 5:36. What time did she finish her walk?

Use the clock if it is helpful.

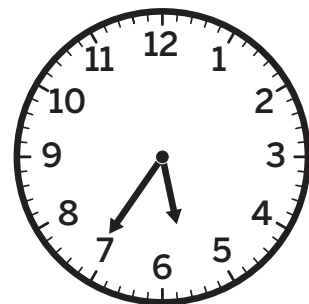

i Show or explain your thinking.

answer: _____

- 2** It took Jada 34 minutes to give her dog a bath. She finished the bath at 4:06. What time did she start the bath?

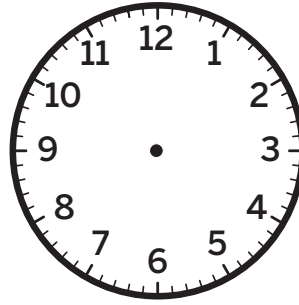

Use the clock if it is helpful.

i Show or explain your thinking.

answer: _____

- 3** It took Jada 25 minutes to make dog treats. She started making the treats at 10:58. What time did she finish making the treats?

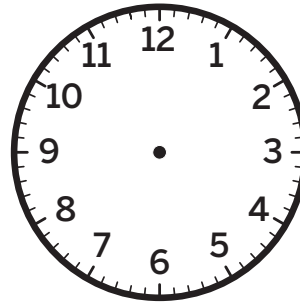

Use the clock if it is helpful.

i Show or explain your thinking.

answer: _____

Practice 6.12

Name _____ Date _____

- 4  It took Jada 22 minutes to eat breakfast. She started her breakfast at 7:15. What time did she finish eating breakfast?

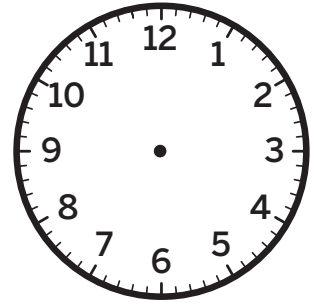

Spiral Review

For Problems 5–8, determine the value of the expression.

5 9×5 _____

6 8×7 _____

7 4×4 _____

8 10×9 _____

- 9 Determine the sum.

$$159 + 421$$

 Show your thinking.

answer: _____

Name _____ Date _____

Fractions of Shape and Time Addition and Subtraction Patterns

🕒 3.MD.1, 3.NBT.2, SMP.1, SMP.2

The Time in Between

Let's take a closer look at elapsed time.

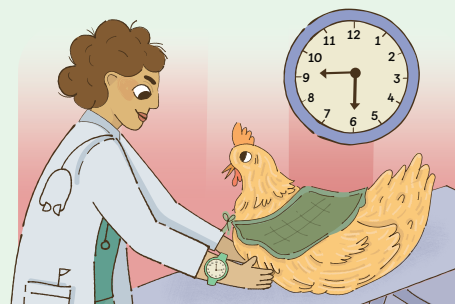

Warm-Up



eyes on teacher

I am a doer of math.

When do you need to know how long something is going to last?

Activity

1

Visiting the Vet

Solve the time problems. You can use the clocks if they are helpful.

1 How long was Sasha and Evelyn's first visit to the vet?

Time the visit began

Time the visit ended

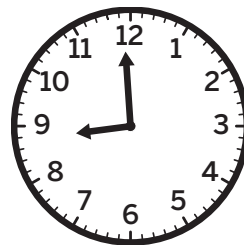
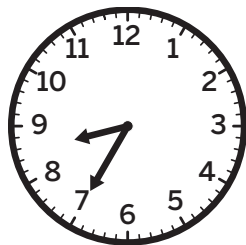

Show or explain your thinking.

answer: _____

1**Visiting the Vet (continued)**

- 2** Sasha made a table logging each visit she took to the vet. Use the information from Problem 1 to complete the first row of the table. Then complete each missing section of the table to show how long she spent at the vet during each visit.

Arrival time	Length of visit	Departure time
8:35	_____ minutes	8:59
9:25	_____ minutes	10:02
11:47	_____ minutes	12:21
2:08	_____ minutes	2:56

3 Discuss 

For Problem 1, how did you determine the amount of time Evelyn was at the vet?

Driving Around Town

Solve the time problems. You can use the clocks if it is helpful.

- 4 How long did it take Sasha to drive from the vet to the store?

Time she left the vet

Time she arrived at the store

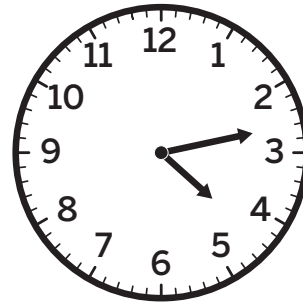
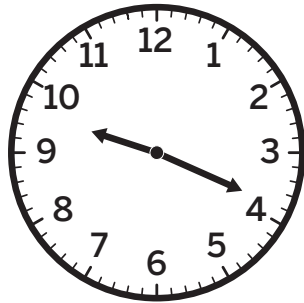

i Show or explain your thinking.

answer: _____

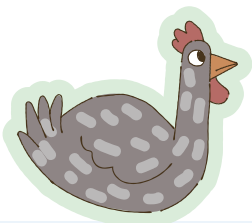

Driving Around Town (continued)

- 5 Sasha headed home after the store but got stuck in traffic. The drive from the store to her house lasted from 4:55 p.m. to 5:49 p.m. How long was the ride home?

 Show or explain your thinking.

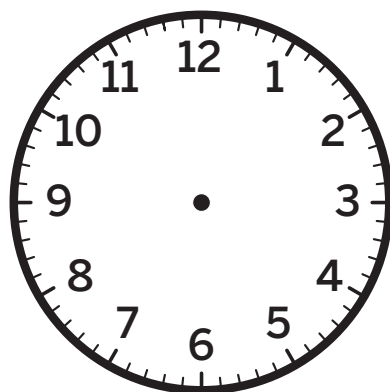

answer: _____



Summary 6.13

When given the start and end times, whether they are in the same hour or different hours, you can count up or count back to determine the elapsed time.

Count up from the start time

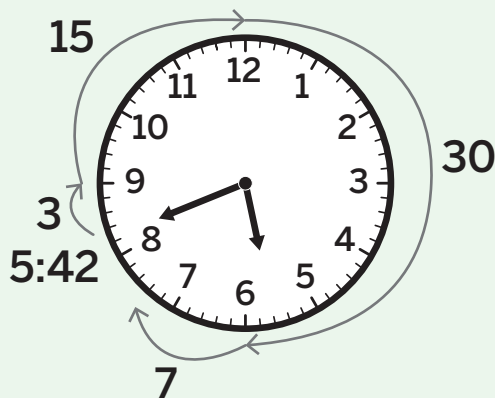

Count back from the end time

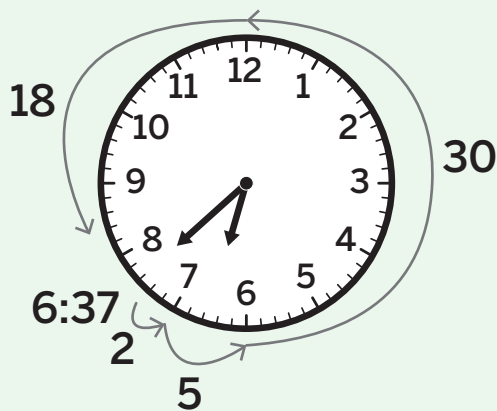

Elapsed time: 55 minutes

Practice 6.13

- 1 How long was Priya's haircut? Use the clocks if it is helpful.

Time the haircut began

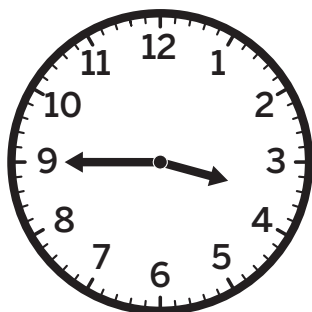

Time the haircut ended

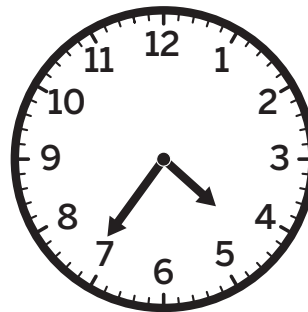

i Show or explain your thinking.

answer: _____

- 2 Han went on a bike ride that lasted from 2:35 p.m. to 3:12 p.m. How long was his bike ride? Use the clock if it is helpful.

i Show or explain your thinking.

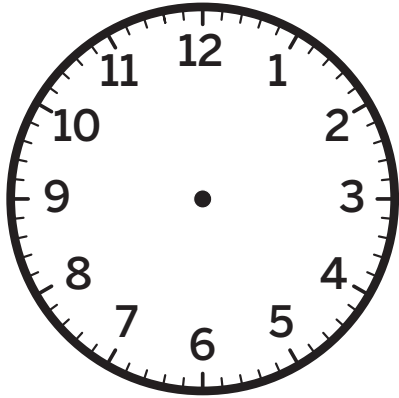

answer: _____

- 3 Clare practiced the piano from 6:06 p.m. to 6:42 p.m. How long did Clare practice the piano? Use the clock if it is helpful.

i Show or explain your thinking.

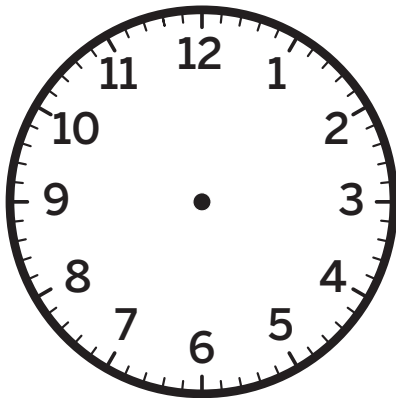

answer: _____

- 4  How long was Diego's swim lesson?

Time the swim lesson began Time the swim lesson ended

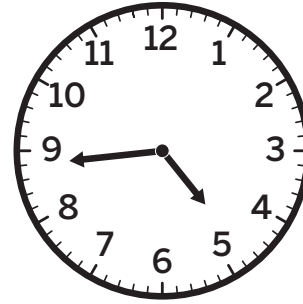

_____ minutes

Spiral Review

For Problems 5 and 6, determine the value of the expression.

5 7×6 _____

6 9×3 _____

- 7 Determine the difference.

$$350 - 137$$

 Show your thinking.

answer: _____

All Kinds of Time

Let's write and solve time problems.

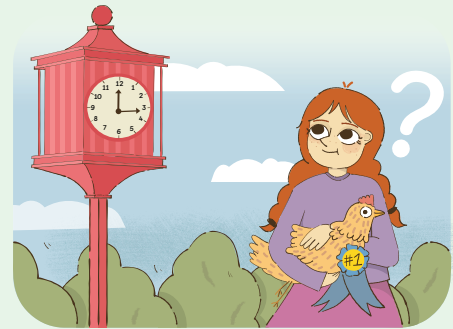

I am a doer of math.

What questions do you have about the math today? Who can you ask to help you answer those questions?

Warm-Up



eyes on teacher

Activity

1

All Together Now!

Hands-On

Solve the time problems. You can use the clocks if it is helpful.

 Show or explain your thinking.

- 1 Priya got off the bus at 4:05 p.m. The bus ride lasted 27 minutes. When did Priya get on the bus?

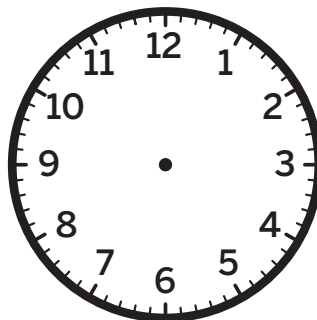

answer: _____

1

All Together Now! (continued)

i Show or explain your thinking.

- 2** The school assembly started at a quarter to 11:00 a.m. and finished at 11:18 a.m. How long was the assembly?

answer: _____

- 3** Clare spent $\frac{3}{4}$ of an hour completing a puzzle. It took Han 52 minutes to complete the same puzzle. They both started their puzzles at 3:30 p.m. What time did they finish? You can use the clock or number line if it is helpful.

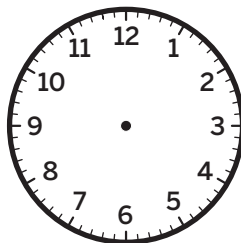

Clare: _____

Han: _____

- 4** Discuss 

How did you identify the unknown in each problem?

Make Your Own Math Problem

- 5 Write and solve a time problem based on Sasha and Evelyn for the unknown you were assigned.

Your unknown: _____

answer: _____

6 **Discuss** 

Are the minutes or times reasonable in the context of your problem? Why or why not?

Summary 6.14

The unknown in a time problem can be the start time, the end time, or the elapsed time. When solving and writing time problems, it is important to consider what times are reasonable.

Start time

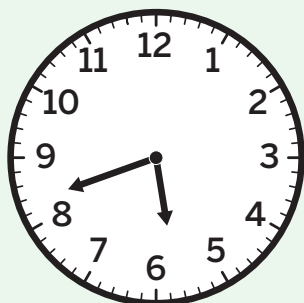

End time



Elapsed time: 55 minutes

Practice 6.14

- 1 Priya's ballet lesson started at 4:25 p.m. The lesson lasted 32 minutes. What time did the lesson end? Use the clock if it is helpful.

i Show or explain your thinking.

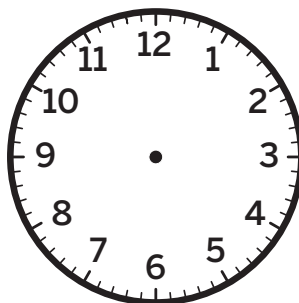

answer: _____

- 2 Han got to the park at 9:35 a.m. and left at 10:22 a.m. How long was Han at the park? Use the clock if it is helpful.

i Show or explain your thinking.

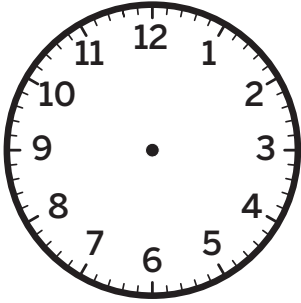

answer: _____

- 3 Write and solve an elapsed-time problem.

i Show or explain your thinking.

answer: _____

Practice 6.14

Name _____ Date _____

- 4  Clare finished her homework at 5:04 p.m. It took her 22 minutes to do her homework. What time did she start her homework?

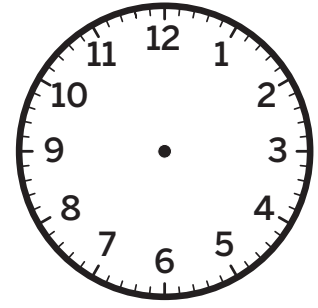

Spiral Review

For Problems 5–8, determine the value of the expression.

5 7×3 _____

6 4×5 _____

7 8×2 _____

8 9×6 _____

For Problems 9 and 10, locate 1 on the number line and label it with a whole number and a fraction.

 Show your thinking.

9



10

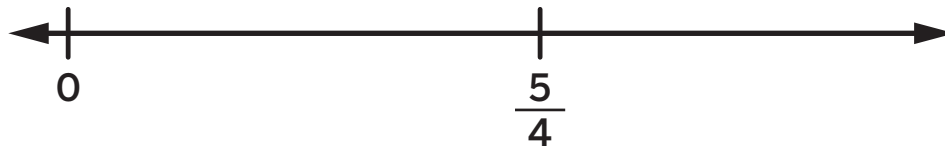

Measurement Problems in Context

✦ Unit Story: Just Stick With It, Sasha

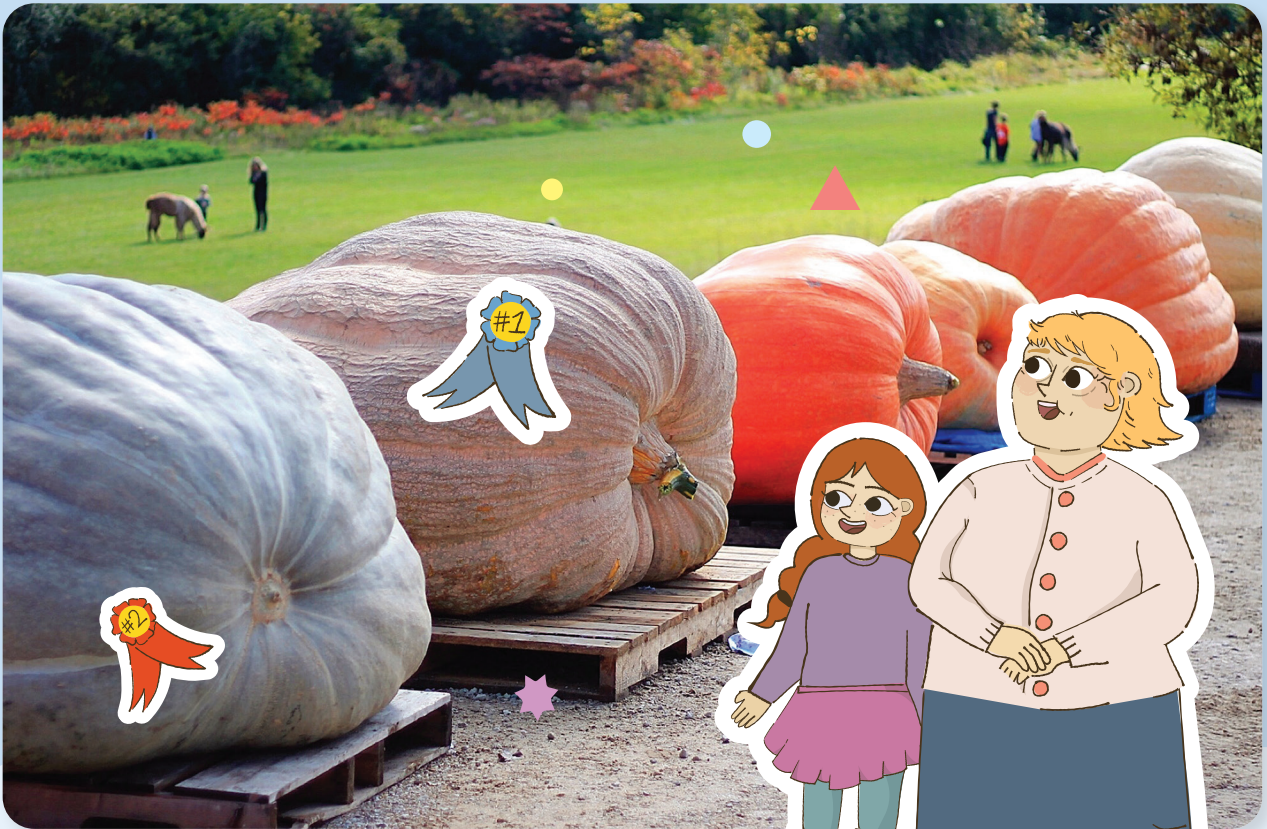

Gretchen Gunda Enger/Shutterstock.com

As Sasha spent time at the county fair, she observed different competitions, including the pumpkin weigh-off.

What are some items you could weigh around the classroom?

Fair Questions

Let's ask questions and solve problems involving liquid volume.



Warm-Up



 eyes on teacher



I am a doer of math.

What are common mistakes that could be made when solving story problems?

Activity

1

Liquid Volume Questions

- 1 Write a mathematical question that could be answered about the pitcher of water and cups.



Paulo Vilela/Shutterstock.com

2 Discuss

What information would you need to solve your mathematical problem?

1**Liquid Volume Questions (continued)**

- 3** Write a mathematical question that could be answered about the amount of liquid in the containers of orange juice. Solve by writing an equation.

Container A**Container B**

equation: _____

At the Farm

Represent each story problem and solve using any strategy.

i Show your thinking.

- 4** Farmer Bill and his daughter Sammy have 24 liters of water stored in their rain barrels for their pumpkin plants. If they have 6 pumpkin plants, how much water does each plant get?

answer: _____

- 5** Farmer Joy has 8 watering cans. If each watering can holds 3 liters of water, how many liters of water does she have in all of her watering cans?

answer: _____

At the Farm (continued)

i Show your thinking.

- 6** Farmer Leslie used 337 liters from his rain barrels to water his giant pumpkins on Day 1. He used 173 liters of water on Day 2. How many liters of water did he use to water his giant pumpkins on Day 1 and Day 2?

answer: _____

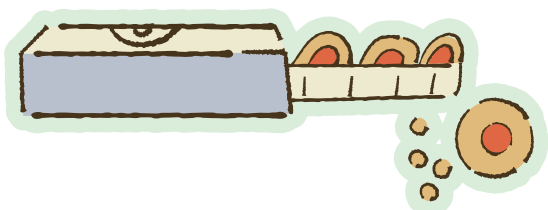

Summary 6.15

You can ask and answer questions about liquid volume using the 4 operations. There are many different representations you can use to show the problem.

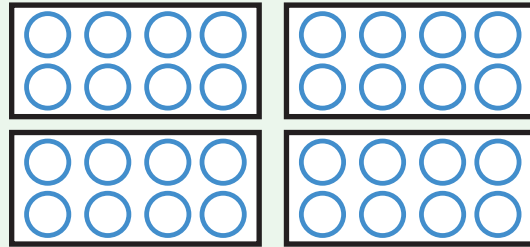
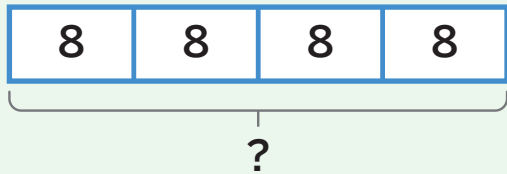

$$4 \times 8 = ?$$

Practice 6.15

- 1 Write 1 mathematical question that could be answered about the milk jug and the drinking glasses.



For Problems 2 and 3, represent the story problem and solve using any strategy.

- 2** Diego's mother evenly splits 21 liters of sports drink into 7 large jugs. How many liters will be in each jug?

i Show your thinking.

answer: _____

- 3** Jada has 7 bottles of lemonade. Each bottle contains 4 liters of lemonade. How many liters of lemonade does Jada have in all?

i Show your thinking.

answer: _____

Practice 6.15

Name _____ Date _____

- 4**  Last week, Han's horse drank 280 liters of water. This week, his horse drank 175 liters of water. How much water did Han's horse drink for both weeks?

_____ liters

Spiral Review

For Problems 5–10, determine the value of the expression.

5 3×4 _____

6 5×7 _____

7 6×6 _____

8 8×8 _____

9 2×9 _____

10 7×6 _____

11 Round 275 to the nearest ten. _____**12** Round 275 to the nearest hundred. _____**13** Round 94 to the nearest hundred. _____**14** Round 94 to the nearest ten. _____

Now Weight

Let's solve problems involving weight.



Warm-Up



eyes on teacher



We are a math community.

How can you make your partner feel heard when they are sharing ideas in math class?

Activity

1

Weight Questions

- 1 Write a mathematical question that could be answered about the weight of the giant pumpkins.



Peter Turner Photography/Shutterstock.com

1**Weight Questions (continued)**

- 2** Write a mathematical question that could be answered about the small pumpkins.



Elisanth/Shutterstock.com

3 **Discuss** 

How are your mathematical questions for Problem 1 and Problem 2 similar and different?

Pig Weigh-Off

Represent each situation and use estimation strategies for Problems 4 and 5. Then solve and write an equation using a symbol for the unknown value.

i Show your thinking.

- 4** Sasha stopped at the pig weigh-off. The winning pig's owner said, "This pig weighs 121 kilograms! That is 439 kilograms less than my smallest bull." How much does his smallest bull weigh?

estimation: _____ equation: _____

answer: _____

- 5** Sasha met another pig farmer at the weigh-off. The farmer said, "I have 3 pigs I want to bring to the fair. Their weights are 116 kilograms, 309 kilograms, and 189 kilograms." What is the difference between the heaviest and lightest pigs?

estimation: _____ equation: _____

answer: _____

2

Pig Weigh-Off (continued)

- 6 The owner of the winning pig shared that the pig gained the same amount of weight each week for 8 weeks. The pig gained 72 kilograms during that time. How many kilograms did the pig gain each week?

equation: _____

answer: _____

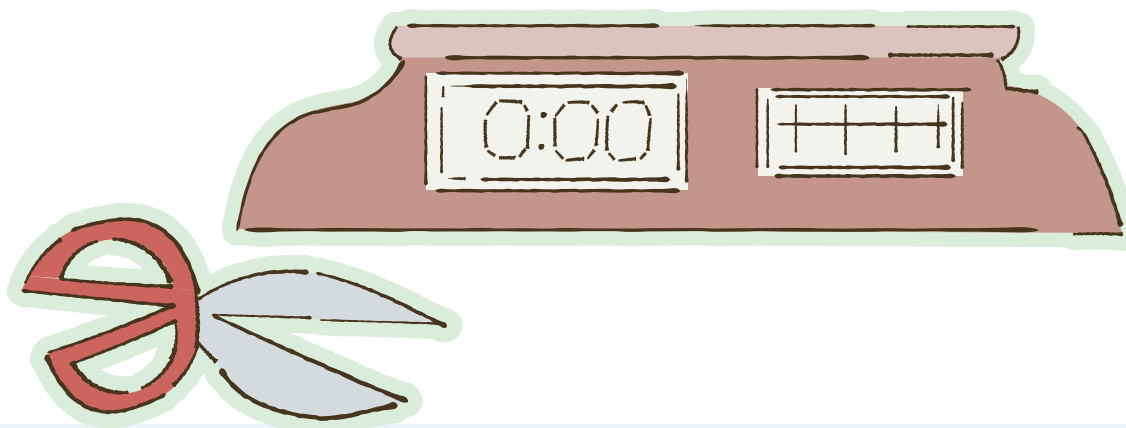

Summary 6.16

You can use the same strategies you are familiar with to help you solve real-world problems about weight.

My pumpkin's weight increased the same amount each day for 6 days. My pumpkin's weight increased 54 kilograms during that time.

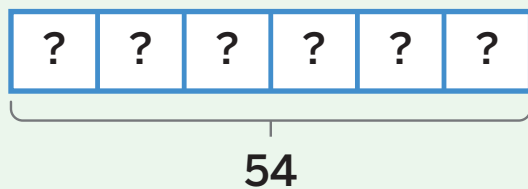

$$6 \times ? = 54$$

Practice 6.16

- 1 Write 2 mathematical questions that could be answered about the watermelons.

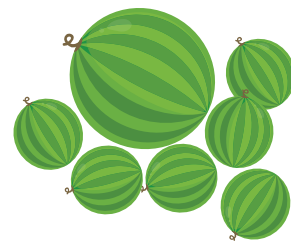

For Problems 2 and 3, represent the story problem and solve using any strategy. Then write an equation using a symbol for the unknown value.

- 2 A farmer has 63 kilograms of hay to divide evenly between 9 hay troughs. How much hay will the farmer put in each trough?

 Show your thinking.

answer: _____

equation: _____

- 3 The weights of a family of gorillas are 109 kilograms, 68 kilograms, and 217 kilograms. What is the difference in weight between the two heaviest gorillas?

 Show your thinking.

answer: _____

equation: _____

- 4  The largest cow at the petting zoo weighs 523 kilograms. This is 152 kilograms more than the smallest cow at the petting zoo. How much does the smallest cow weigh?

_____ kilograms

Spiral Review

For Problems 5–8, determine the value of the expression.

5 5×5 _____

6 3×7 _____

7 9×10 _____

8 5×8 _____

- 9 Determine the sum.
 $593 + 226$

 Show your thinking.

answer: _____

Name _____ Date _____

Number Flexibility to 100 Addition and Subtraction Patterns

3.MD.2, 3.MD.1, 3.OA.3, SMP.2, SMP.6, SMP.7, SMP.8

For Good Measure

Let's solve problems involving measurement and present the solutions.



Warm-Up



eyes on teacher



I am a doer of math.

How can keeping your work organized help you solve math problems?

Activity

1

A Day at the Fair

Solve the story problems about your day at the fair. Then choose 1 problem and create a poster that shows or explains your thinking.



Show or explain your thinking.

1

You arrived at the fair! Entry to the fair is \$9 a person. You went there with 6 other people. How much did it cost your group to enter the fair?

answer: _____

1**A Day at the Fair (continued)**

i Show or explain your thinking.

- 2** You spent 48 minutes at the carnival and left at 12:10 p.m. What time did you get to the carnival?

answer: _____

- 3** You visited a life-size sculpture of a cow made of butter. The butter cow weighs 273 kilograms, which is 277 kilograms less than a cow at the fair. How much does the cow at the fair weigh?

answer: _____

- 4** Before you went home, you stopped for grilled corn on the cob. There were 56 ears of corn arranged in 8 equal rows on the grill. How many ears of corn were in each row?

answer: _____

Summary 6.17

All 4 operations can be used to solve problems involving measurement of time, liquid volume, and weight.

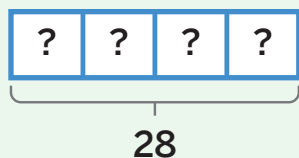

$$4 \times ? = 28$$

$$28 \div 4 = ?$$

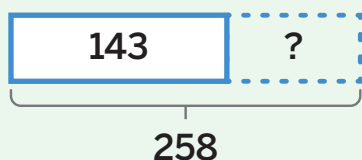

$$143 + ? = 258$$

$$258 - 143 = ?$$

Practice 6.17

For Problems 1–3, represent the story problem and solve using any strategy.

- 1 Jada started playing games at 1:25 p.m. She played games for 44 minutes. What time did she finish playing games?



Show or explain your thinking.

answer: _____

- 2 Diego played the pick-a-lollipop game. There were 72 lollipops arranged in 9 equal rows. How many lollipops were in each row?



Show or explain your thinking.

answer: _____

- 3 Each bundle of ride tickets costs \$6. Han's mother buys Han and each of his 3 friends a bundle of ride tickets. What was the total cost of all the bundles of ride tickets?



Show or explain your thinking.

answer: _____

- 4  Clare got in line for the Ferris wheel at 5:53 p.m. She got off the ride at 6:18 p.m. How long was Clare at the Ferris wheel?

_____ minutes

Practice 6.17

Name _____ Date _____

- 5  The petting zoo has 2 ponies. The weight of the smaller pony is 184 kilograms. This is 109 kilograms less than the larger pony. How much does the larger pony weigh?

_____ kilograms

Spiral Review

For Problems 6–9, determine the value of the expression.

6 8×4 _____

7 5×6 _____

8 3×3 _____

9 2×7 _____

- 10 Determine the difference.
 $546 - 329$

 Show your thinking.

answer: _____

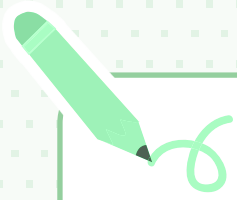

Notes:

Math at Work

Llamas and alpacas come from South America. They are related to camels. An adult alpaca can weigh about 90 kilograms. An adult llama can weigh about 204 kilograms. About how many more kilograms can an adult llama weigh than an adult alpaca?

Large animal veterinarians help take care of the health and wellness of larger animals, such as llamas, alpacas, horses, cows, or sheep. They might measure the weights of animals they care for.



BearFotos/Shutterstock.com. 279photo Studio/Shutterstock.com.

Math in the World

Roosters are male chickens. They crow before sunrise to greet the day and to protect other chickens. If a rooster crows at 5:47 a.m. and then again at 8:13 a.m., how many hours and minutes pass between their crows?



Wassana Panapute/Shutterstock.com.

Math Mindset

How can you use a clock to help solve problems involving time?

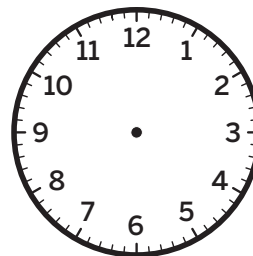

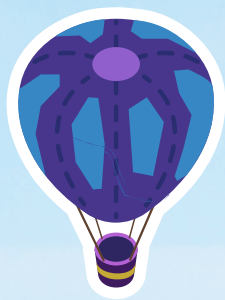

Unit 7

Two-Dimensional Shapes and Perimeter

Big Ideas in This Unit

- CC1 Measuring
- CC2 Addition and Subtraction Patterns
- Number Flexibility to 100
- CC3 Square Tiles
- CC4 Analyze Quadrilaterals

Questions for Investigation

- How can a shape have more than 1 name?
- What does perimeter tell you about a shape?
- How do a shape's attributes relate to its perimeter and area?



Explore: Sorting Shapes

How can you categorize shapes?



Unit Story: Through Piho's Eyes

In this story, a polar bear named Piho gets the opportunity to see and experience parts of the world from the same perspective as her friend Taka, an Arctic tern.



Watch Your Knowledge Grow

This is the math you'll explore in this unit. Rate your understanding to see how your knowledge grows!

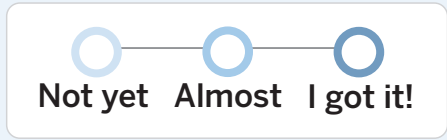

I can . . .	Before	After
Understand that shapes in different categories may share attributes.		
Understand that the shared attributes of different shapes can define a larger category such as quadrilaterals.		
Recognize rhombuses, rectangles, and squares as examples of quadrilaterals.		
Draw examples of quadrilaterals that do not belong to specific categories of shapes.		
Solve real-world problems involving the perimeter of polygons.		
Determine the perimeter of shapes with an unknown side length.		
Draw rectangles with the same perimeter and different areas or same areas and different perimeters.		
Use tiling to show the area of a rectangle.		
Use area models to represent the Distributive Property.		

Reasoning With Shapes

✦ Unit Story: Through Piho's Eyes



beerlogoff/Shutterstock.com

Piho saw many different shapes during her travels.

How could you describe the shapes she saw?

Explore: Sorting Shapes

How can you categorize shapes?



Warm-Up



 eyes on teacher

Discuss  What do you notice? What do you wonder?

Through Piho's Eyes

Unit Story





Sort the shapes into categories. Then create a name for each category based on how you sorted.

- What attributes does each shape in your category have?
- How can you make your category more unique?

Ways to be a mathematician

- 1** I can take my time to think about a challenging problem before trying to solve it.

○ ——— ○ ——— ○
Not yet Almost I got it!



- 2** I can choose the tool that is just right for the problem I am solving.

○ ——— ○ ——— ○
Not yet Almost I got it!



- 3** I can see how ideas are connected and use patterns to help solve problems.

○ ——— ○ ——— ○
Not yet Almost I got it!

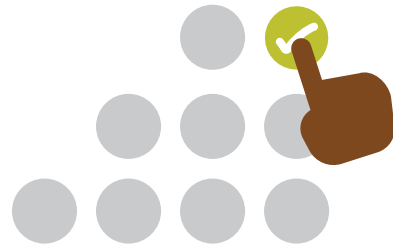

Piho's Shapes

Let's describe and compare shapes.

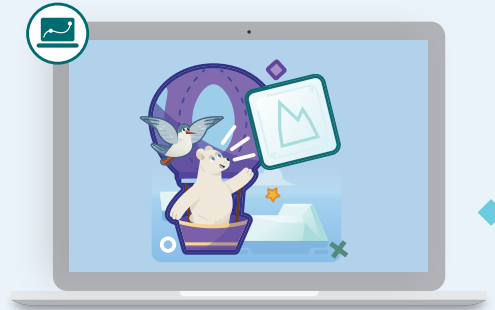

Warm-Up

1

 eyes on teacher

We are a math community.

What different groups do you belong to? Who else belongs to those groups?

Activity

1

Shape Hunt

2

Draw a shape that matches the given clues.

 Draw

0 square corners

some sides of different lengths

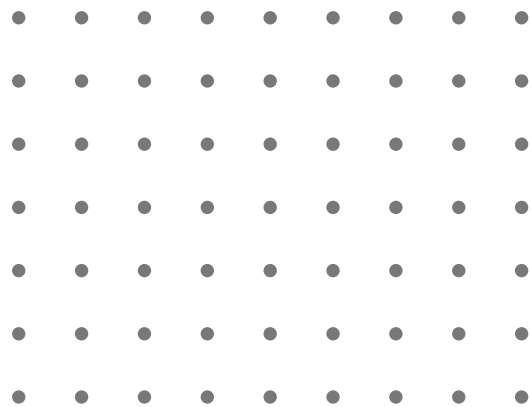

1**Shape Hunt (continued)****2****Discuss** 

Which shapes match the given clues? What do you notice about shapes that match the clues?

0 square corners

some sides of different lengths

Shape A



Shape B



Shape C

**3**

Draw a shape that matches the given clues.

Draw 

more than 3 sides

some square corners

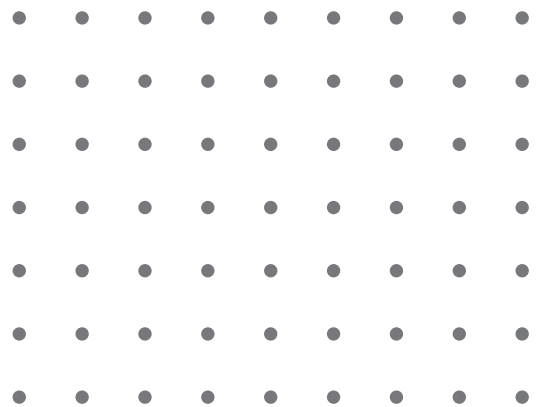
**4**

Let's compare shapes.

Guess My Shape, Piho!

- 5** Circle 1 clue that describes only your shape and none of the other shapes.

Your Shape



Clues	all sides of equal length	square corners	quadrilateral

- 6** A rectangle was added to the collection. Circle 2 clues that, when combined, describe only your shape and none of the other shapes.

Your Shape



Clues	all sides of equal length	square corners	quadrilateral

Describe

How did your thinking change when the rectangle was added?

- 7** Circle 2 clues that when combined describe only your shape and none of the other shapes.

Your Shape



Clues	pentagon	flat shape	0 square corners
	straight sides		fewer than 6 sides

Guess My Shape, Piho! (continued)

- 8** Circle 2 clues that when combined describe only your shape and none of the other shapes.

Your Shape



Clues	straight sides	0 square corners	quadrilateral
	1 pair of sides of equal length		at least 2 sides

9

Your Shape



Shape A



Shape B



Shape C



Write 1 clue that describes your shape and none of the other shapes.

Clue	
-------------	--

Write 1 clue that describes your shape and at least 1 of the other shapes.

Clue	
-------------	--

Summary 7.02

Different shapes can share some of the same attributes. Using precise language can help you describe the defining attributes of shapes.

more than 3 sides

some square corners

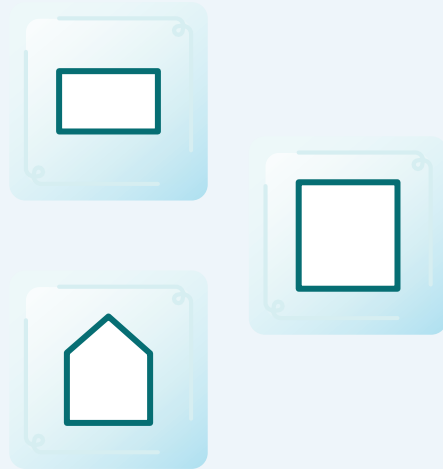

Practice 7.02

1 Here are 2 quadrilaterals.

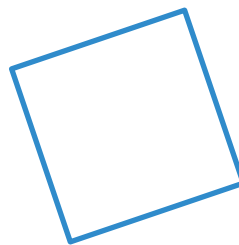
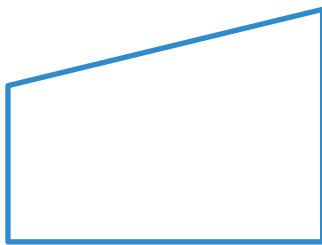

Select *all* the attributes that the quadrilaterals share.

- (A) 4 square corners
- (B) 4 side lengths
- (C) 3 square corners
- (D) 2 square corners
- (E) 2 opposite side lengths are equal

For Problems 2–4, refer to Quadrilaterals A–D.

A

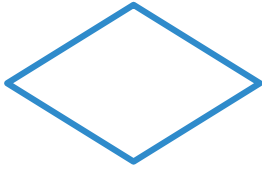

B



C



D



2

Choose 1 of Quadrilaterals A–D to be your shape. Write clues to describe your shape and none of the other shapes.

3

Select 1 attribute Quadrilaterals B and D have in common.

- (A) They have 4 square corners.
- (B) They have 2 opposite sides that are the same length.

4

Name 1 attribute Quadrilaterals C and D share. Then name 1 way they are different.

Spiral Review

i Show your thinking.

5 Determine the sum.

$$474 + 352$$

answer: _____

6 Determine the difference.

$$602 - 371$$

answer: _____

For Problems 7–14, determine the value of the expression.

7 $12 \div 4$ _____

8 9×4 _____

9 8×9 _____

10 $16 \div 4$ _____

11 $30 \div 5$ _____

12 6×8 _____

13 $45 \div 5$ _____

14 7×5 _____

Rectangles, Squares, and Rhombuses

Let's explore what makes certain quadrilaterals what they are.



Warm-Up



eyes on teacher



I can be all of me in math class.

You have a first and last name and maybe a middle name. What does a name mean to you?

Activity

1

Rectangles and Squares

These are rectangles.

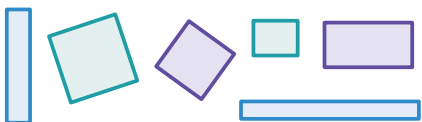

These are *not* rectangles.

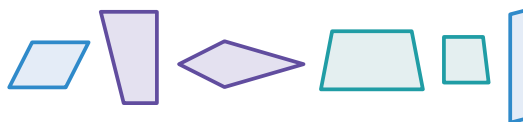

1 Here are Figures A–J. Circle the letters of *all* the rectangles.

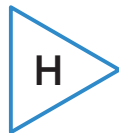
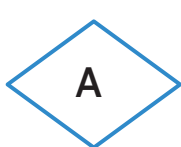

2 List the attributes of a rectangle.

1

Rectangles and Squares (continued)

These are squares.

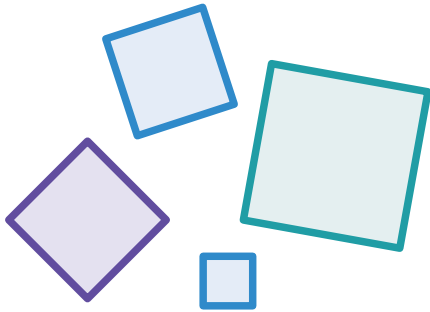

These are *not* squares.

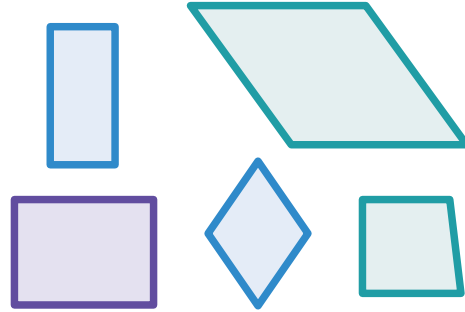

3 Here are Figures A–J again. Circle the letters of *all* the squares.

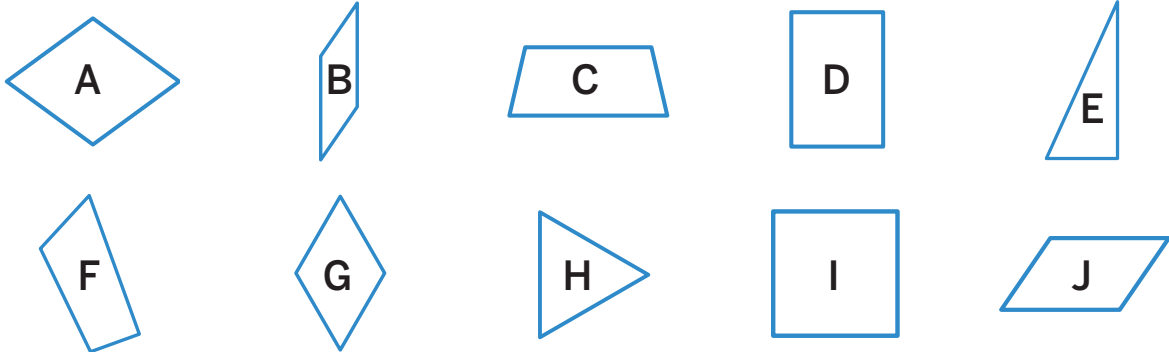

4 List the attributes of a square.

Rhombuses

These are rhombuses.

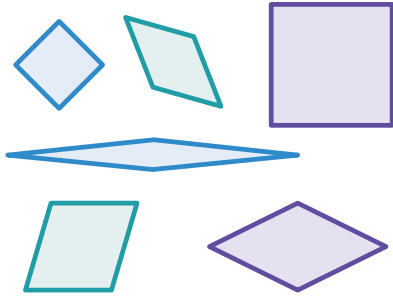

These are *not* rhombuses.

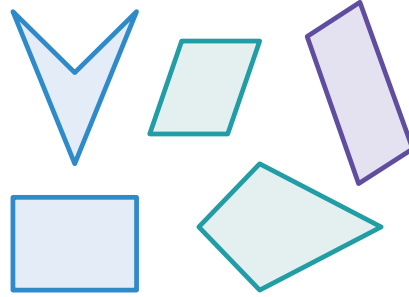

5 Here are Figures A–J again. Circle the letters of *all* the rhombuses.

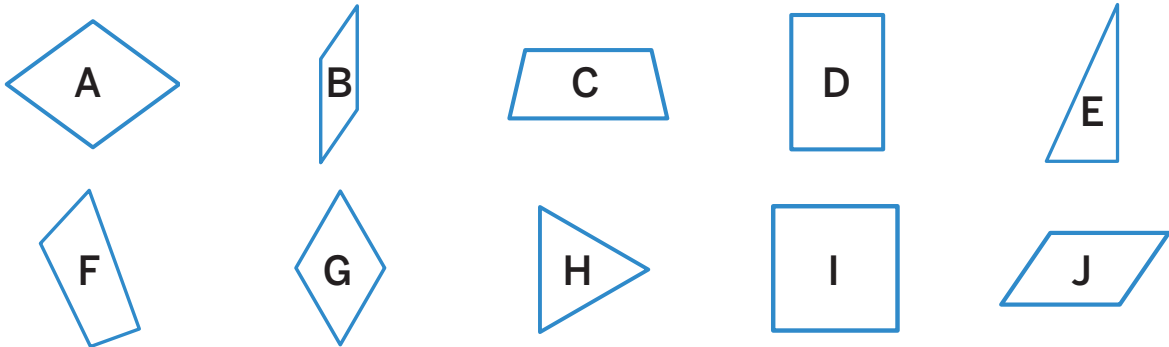

6 List the attributes of a rhombus.

7 **Discuss** 

How are rhombuses similar to and different from other categories of shapes you are familiar with?

Summary 7.03

Rectangles, squares, and **rhombuses** are all quadrilaterals with shared attributes and defining attributes that make them unique.

rectangle



- 4 straight sides
- 4 square corners

square



- 4 straight sides
- 4 square corners
- All sides are the same length

rhombus



- 4 straight sides
- All sides are the same length

rhombuses A quadrilateral with 4 equal-length sides.

Practice 7.03

- 1 Here are Quadrilaterals A–E. Circle *all* the rectangles. Draw an X on *all* the squares. Draw a star on *all* the rhombuses.

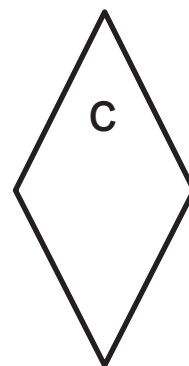
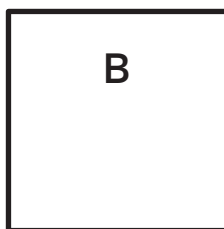
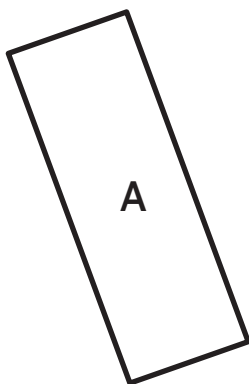

2 Select *all* the attributes of a rectangle.

- (A) 4 unequal side lengths
- (B) 4 straight sides
- (C) 4 square corners
- (D) no square corners

3 Select *all* the attributes of a square.

- (A) 4 equal side lengths
- (B) 4 straight sides
- (C) 4 square corners
- (D) no square corners

4 Han was thinking of a shape. He described the shape as a quadrilateral with 4 equal-length sides. Jada said Han was describing a rhombus. Clare said he was describing a square. Who is correct? Explain your thinking.

Practice 7.03

Name _____ Date _____

- 5  Decide whether each statement is *True* or *False* for this figure.

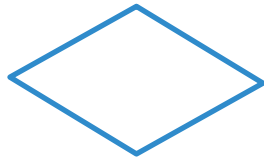

	True	False
The figure is a rhombus.		
It has 4 equal side lengths.		
It has 4 square corners.		
The figure is a square.		
None of its corners are square.		

Spiral Review

For Problems 6 and 7, write 1 fraction that is equivalent to the fraction. Show your thinking on the number line.

6 $\frac{1}{3}$



7 $\frac{1}{4}$



More Quadrilaterals

Let's use the defining attributes of different quadrilaterals to draw and categorize them.

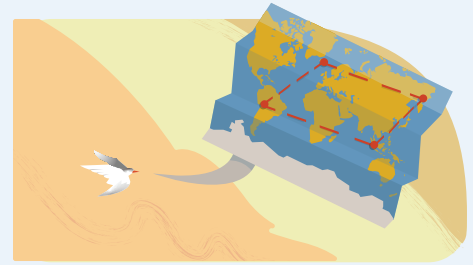

Warm-Up



eyes on teacher



I can be all of me in math class.

How has your thinking changed about what a quadrilateral can look like?

Activity

1

Draw One That Is Not . . .

Draw

1 Draw a quadrilateral that is *not* a square.

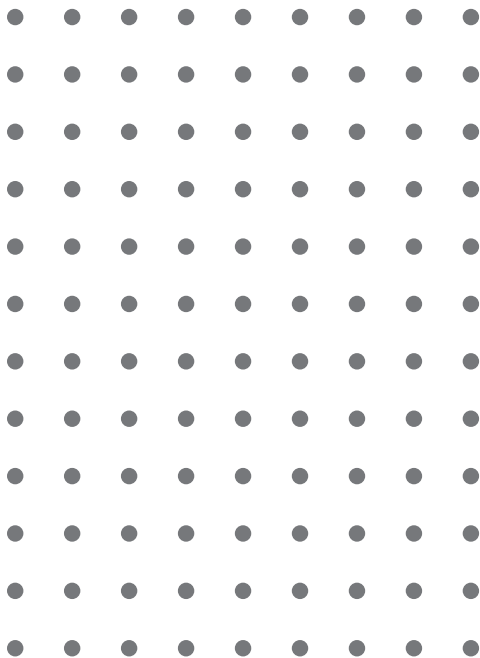

2 Draw a quadrilateral that is *not* a rhombus.

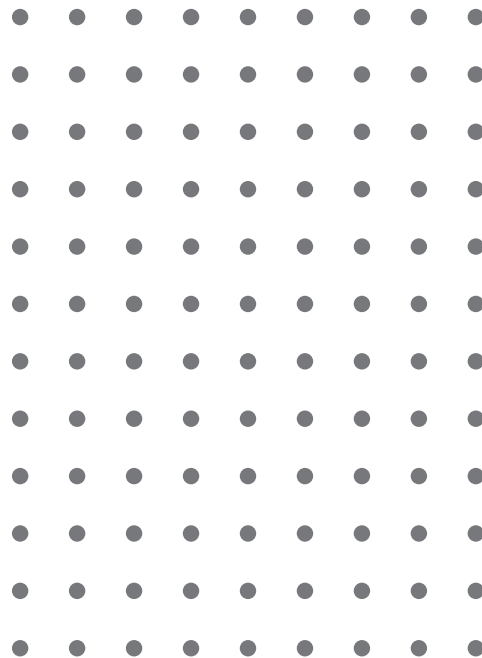

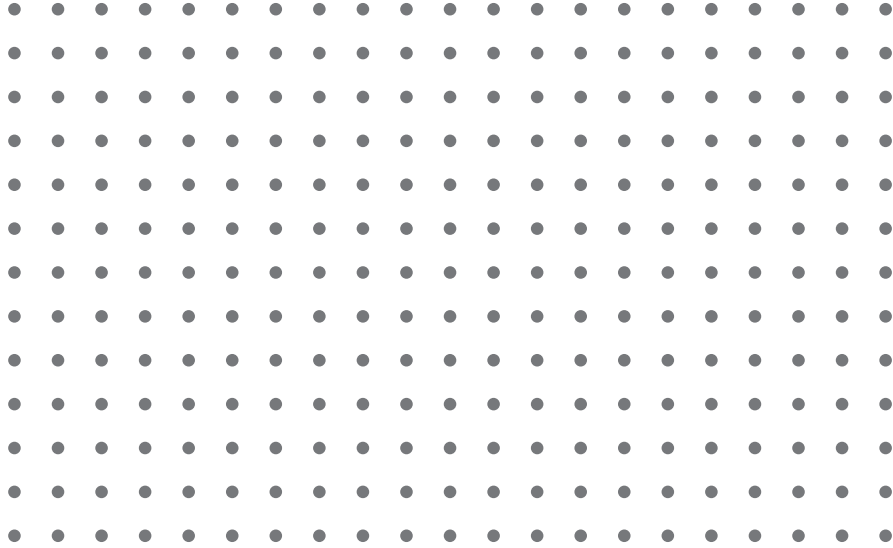
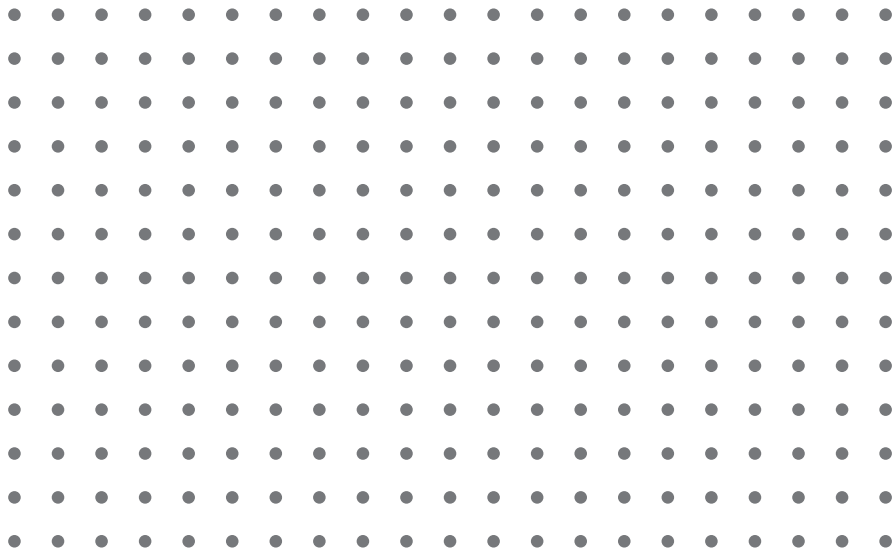
1**Draw One That Is Not . . . (continued)** Draw**3** Draw a quadrilateral that is *not* a rectangle.**4** Draw as many quadrilaterals as you can that are *not* squares, rhombuses, or rectangles.

Categorizing Quadrilaterals

Hands-On

You and your partner will be given a set of cards with different quadrilaterals.

- 5 Look at the 4 categories in the table. Use the categories to sort each of your quadrilaterals. Some shapes may belong in more than 1 category.

Quadrilaterals	Squares
Rectangles	Rhombuses

6 Discuss

Which shapes belong in more than one category? Why can some shapes be called by more than one name?

Summary 7.04

Shapes can belong in different categories because of their shared attributes. The defining attributes of shapes can be helpful in creating examples and non-examples of shapes and in calling them by their most precise name.

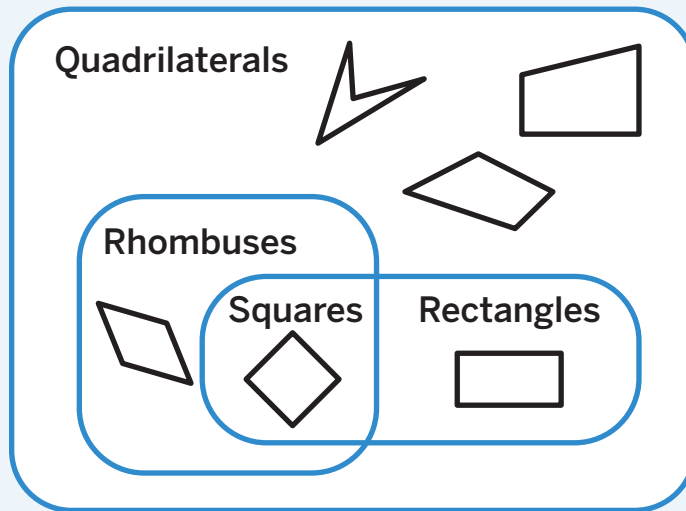

Practice 7.04

- 1 Why can some quadrilaterals be called by more than 1 name?

Use the dot grid for Problems 2 and 3.

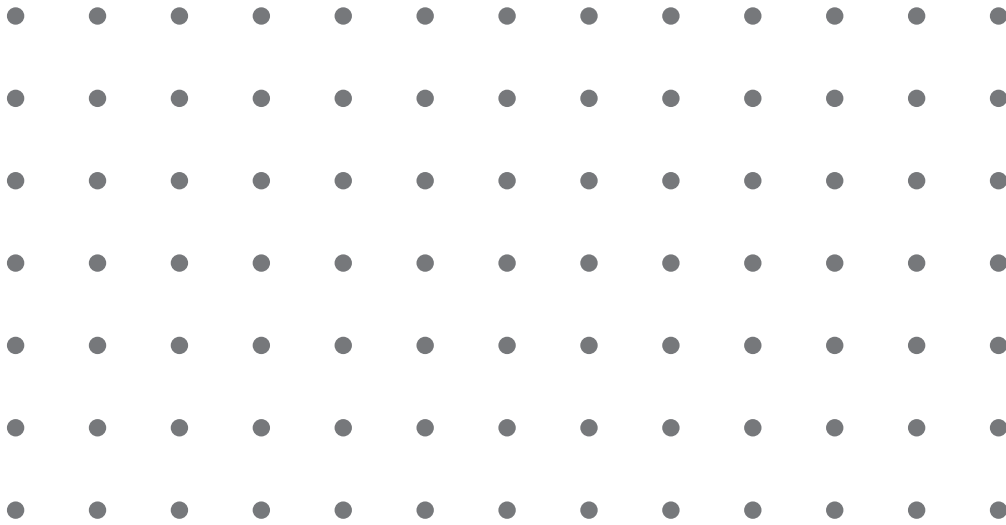

2 Draw a quadrilateral that is *not* a rhombus on the dot grid and label it A.

3 Draw a quadrilateral that is *not* a rectangle on the dot grid and label it B.

4 Diego said he drew a quadrilateral that is not a rectangle. Is Diego correct? Explain your thinking.

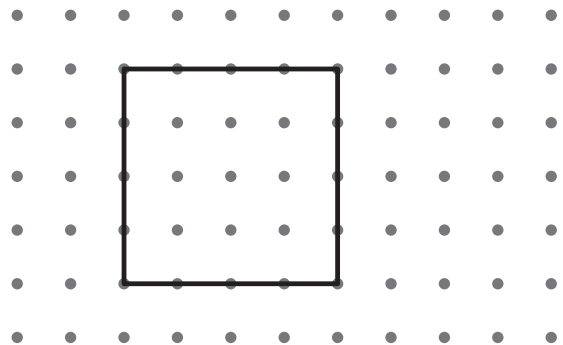

5 Which quadrilateral is *not* a rectangle?

(A)

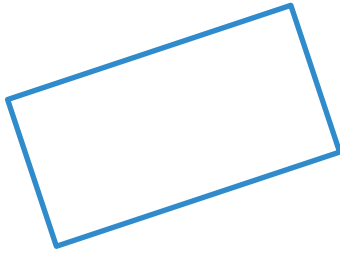

(B)



(C)

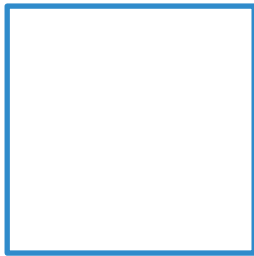

(D)

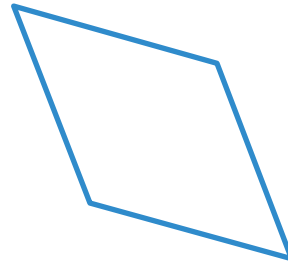

Spiral Review

Use the story problem for Problems 6 and 7.

Each container of slime cost \$9. Jada buys 7 containers of slime. What is the total cost of the slime Jada bought?

6 Write a multiplication equation to represent the problem. Use a ? to represent the unknown value.

7 Solve for the total cost.

 Show your thinking.

answer: _____

Wax Prints

Let's design wax prints using their unique geometric attributes.

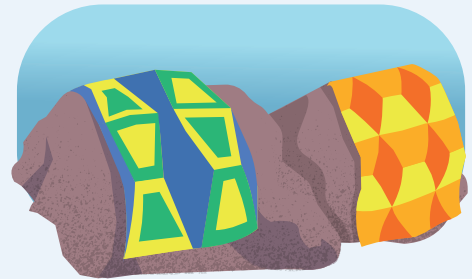

Warm-Up



eyes on teacher



We are a math community.

How can learning about other people's cultures help them feel respected and valued?

Activity

1

Same But Different

Here are some triangles sorted into different groups.

Group A	Group B	Group C	Group D

- Choose 1 group of triangles and describe the triangles in that group.

- Choose another group of triangles and describe the triangles in that group.

Designing a Pattern

Hands-On

You will be given dot paper and a ruler.

- 3 Use the dot paper to design your own wax print pattern. Be sure to:
 - Include *2 different* rhombuses, rectangles, or squares in your pattern.
 - Include *at least* 1 quadrilateral that is *not* a rhombus, rectangle, or square in your pattern.
 - Repeat your pattern *at least* twice to show how it could look on a larger piece of fabric.

Color your wax print design to highlight the quadrilaterals you included.



Summary 7.05

Shapes in the same category can look different and have different attributes.

Triangles with
3 equal side lengths



Triangles with
1 square corner

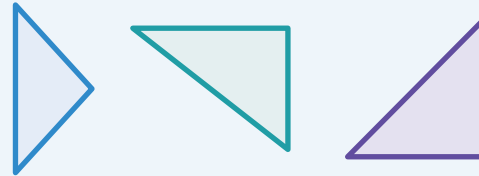

Practice 7.05

Use the image for Problems 1 and 2.

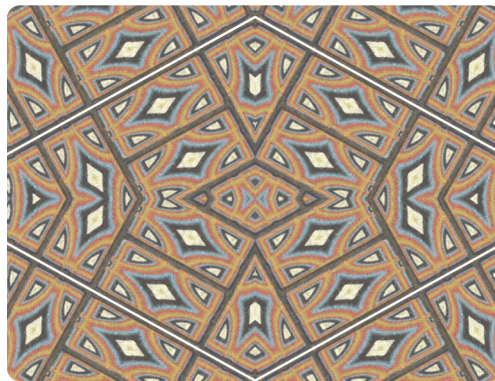

"African Bricks In Kaleidoscope" by Piotr Siedlecki via PublicDomainPictures.net. CC0 1.0.

- 1 Circle 1 rhombus in the pattern.
- 2 Draw a box around 1 quadrilateral in the pattern that is *not* a rhombus. Explain how you know it is not a rhombus.

For Problems 3–6, use the quadrilaterals that have been sorted into 2 groups.

Group A

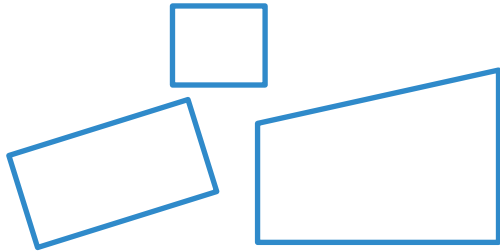

Group B

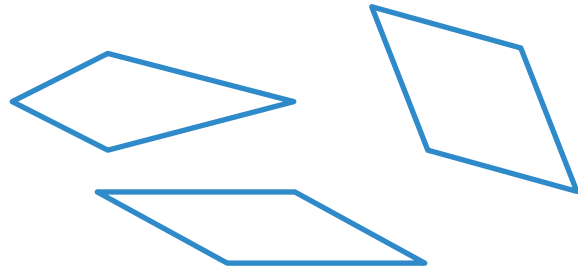

3 Describe the quadrilaterals in Group A.

4 Describe the quadrilaterals in Group B.

5 On the grid, draw a quadrilateral that would *not* belong in Group A or B.

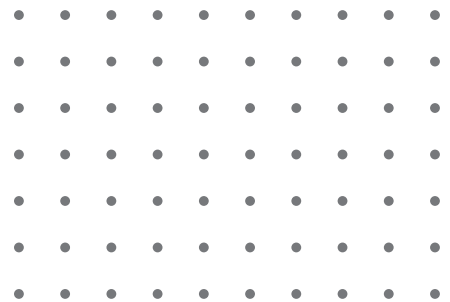

6 Which quadrilateral would belong in Group B?

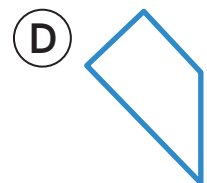
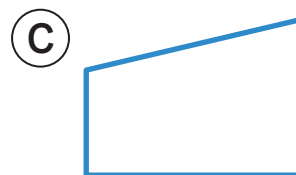
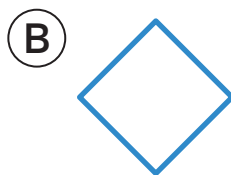

Spiral Review

7 Determine the sum.

$$325 + 317$$

 Show your thinking.

answer: _____

8 Determine the difference.

$$528 - 448$$

 Show your thinking.

answer: _____

For Problems 9–14, determine the value of the expression.

9 $63 \div 9$ _____

10 6×4 _____

11 8×8 _____

12 $54 \div 6$ _____

13 $45 \div 5$ _____

14 7×7 _____



Notes:

What Is Perimeter?

 Unit Story: Through Piho's Eyes



Don Mammoser/Shutterstock.com

Piho visited places all over the world where shapes are used in many ways.

What is an unexpected place you have noticed shapes around you?

Distance Around Shapes

Let's measure the distance around shapes.

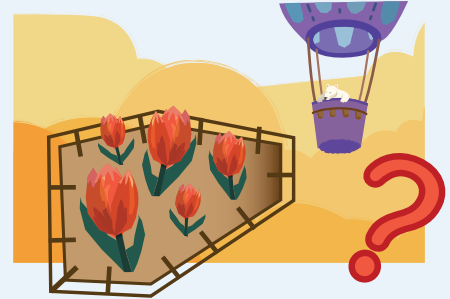

Warm-Up



eyes on teacher



I can be all of me in math class.

You explored a new idea today.
What do you do to help yourself understand new math ideas?

Activity

1

Building Garden Beds

Hands-On

Your group will be given paper clips and a paper with 4 shapes representing Piho's garden beds.

- 1 Use the paper clips to measure the total length of wood around each shape. Record each measurement in the table. Draw sketches if it is helpful.

Shape A	Shape B
_____	_____
Shape C	Shape D
_____	_____

1**Building Garden Beds (continued)**

- 2** For which garden bed will Piho need the most wood to build?

- 3** **Discuss** 

Was your prediction about which bed requires the most wood correct? Why or why not?

Measuring Perimeter

Determine the perimeter of each shape. The distance between 2 tick marks is 1 unit.

i Show your thinking.

4

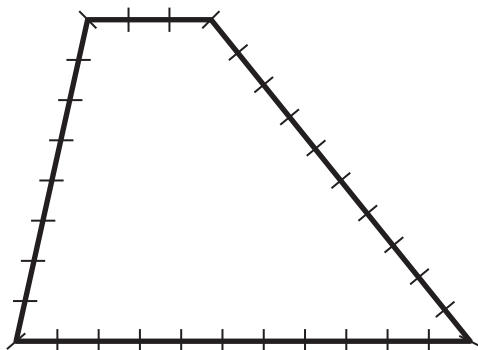

answer: _____

5

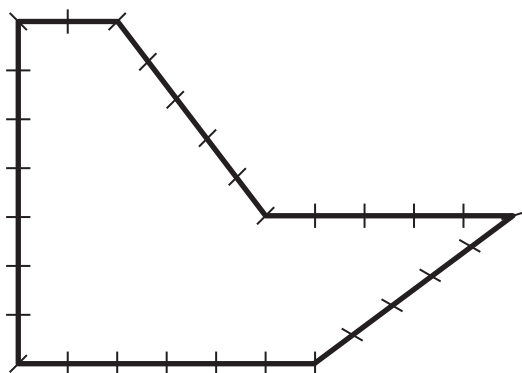

answer: _____

Measuring Perimeter (continued)

 Show your thinking.

6

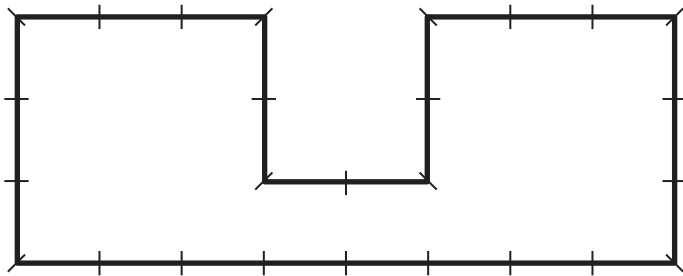

answer: _____

7



answer: _____

- 8 Choose 1 shape from Problems 4–7. Explain how you determined the perimeter of the shape.

Summary 7.06

Perimeter is the total length of the boundary of a two-dimensional shape. You can measure perimeter by counting or calculating the total length of all the sides of a shape.

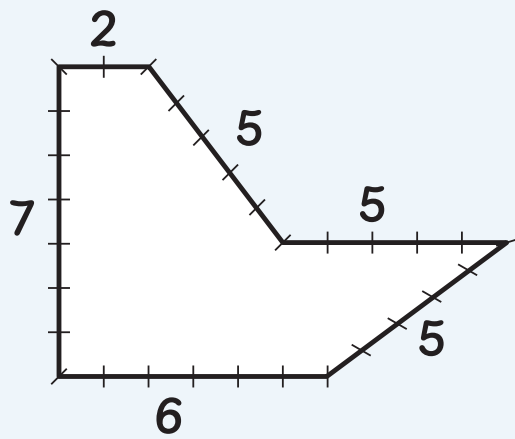

$5 + 5 + 5 + 2 + 7 + 6 = 30$,
so the perimeter is 30 units.

perimeter The total length of the boundary of a two-dimensional shape.

Practice 7.06

For Problems 1 and 2, determine the perimeter of the shape. The distance between 2 tick marks is 1 unit.

 Show or explain your thinking.

1

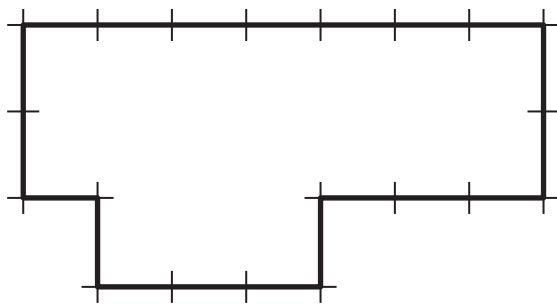

answer: _____

i Show or explain your thinking.

2

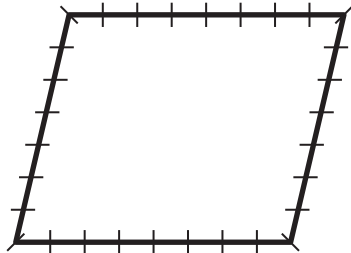

answer: _____

3

Diego says the perimeter of the shape is 12 units. Do you agree? Explain your thinking.

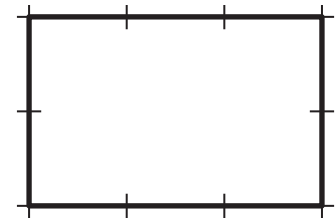

4

i What is the perimeter of the shape? The distance between 2 tick marks is 1 unit.

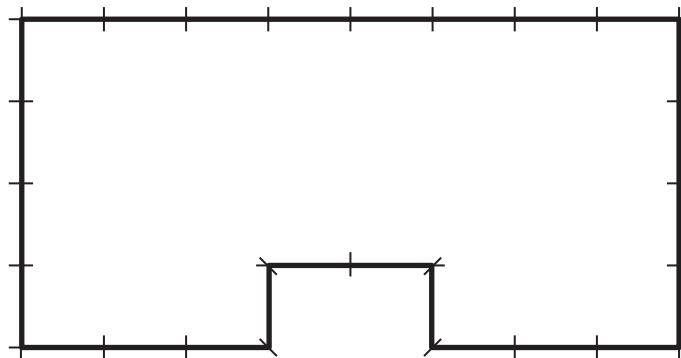

(A) 22 units

(B) 26 units

(C) 24 units

(D) 28 units

5 Which shape does *not* have a perimeter of 16 units? The distance between 2 tick marks is 1 unit.

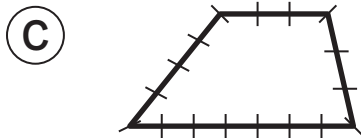
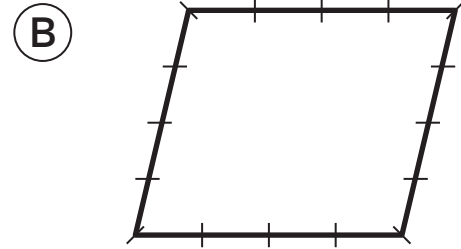
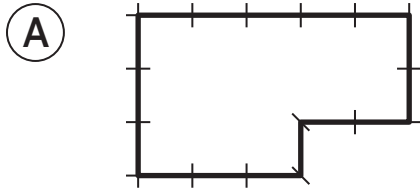

Spiral Review

6 Determine the difference.
461 – 229

Show your thinking.

answer: _____

For Problems 7–10, determine the value of the expression.

7 9×3 _____

8 7×4 _____

9 5×8 _____

10 9×6 _____

Perimeters of Different Shapes

Let's explore the perimeters of different shapes.

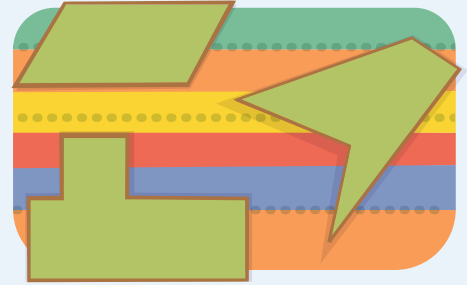

Warm-Up



eyes on teacher



We are a math community.
What differences do you find and appreciate in someone else's work?

Activity

1

All Kinds of Shapes

Determine the perimeter of each shape. The horizontal and vertical distance between any 2 dots is 1 unit.



Show or explain your thinking.

1

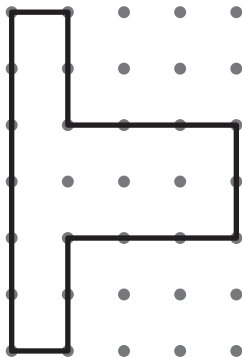

answer: _____

1

All Kinds of Shapes (continued)

 Show or explain your thinking.

2

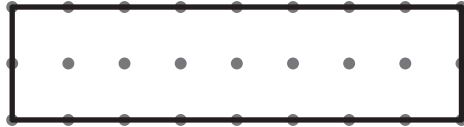

answer: _____

3

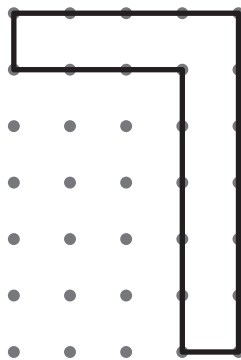

answer: _____

4

Discuss 

What is similar and different about the shapes in Problems 1–3?

Creating Your Own Shapes

Draw 2 different shapes for each given perimeter. Be prepared to explain your thinking.

5 12 units

 Draw

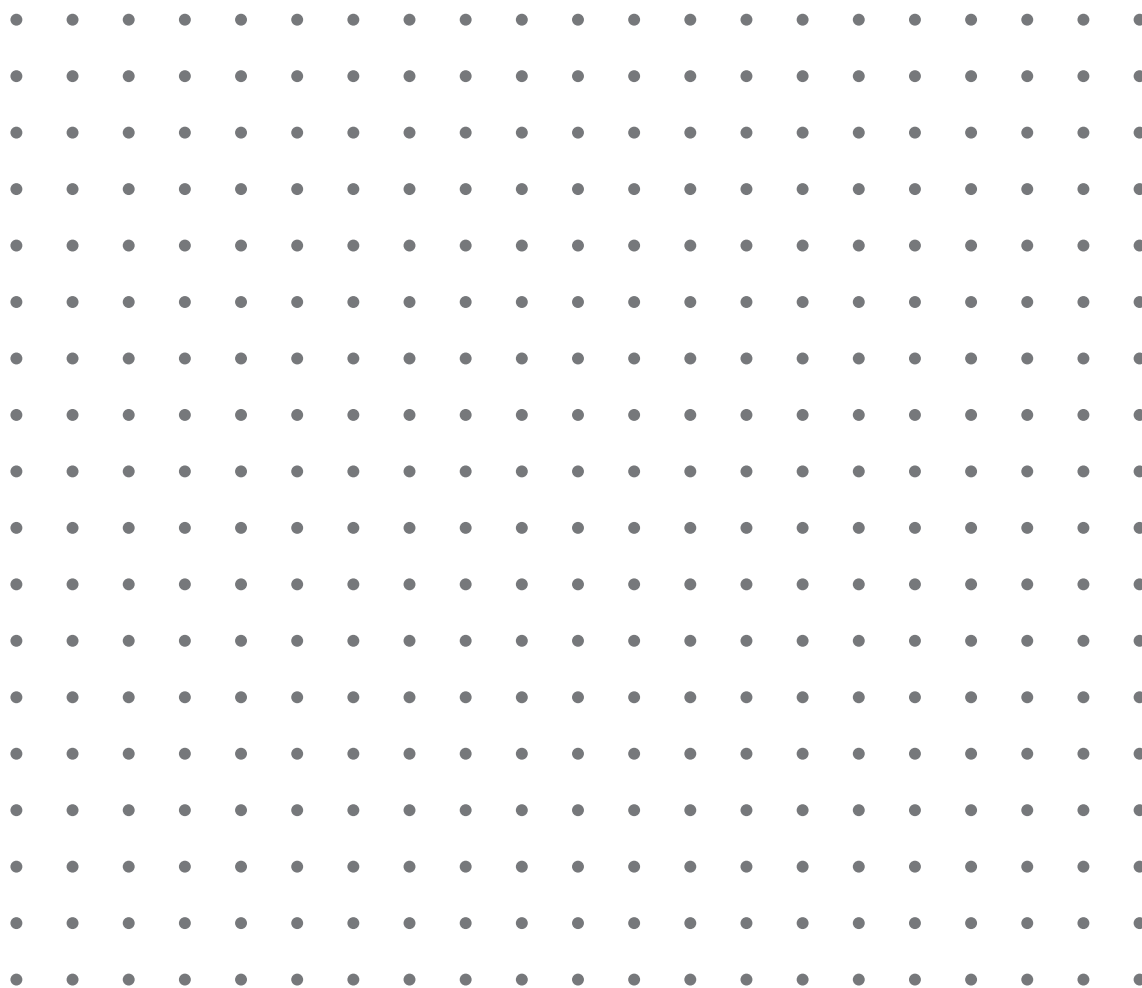

Creating Your Own Shapes (continued)

6 24 units

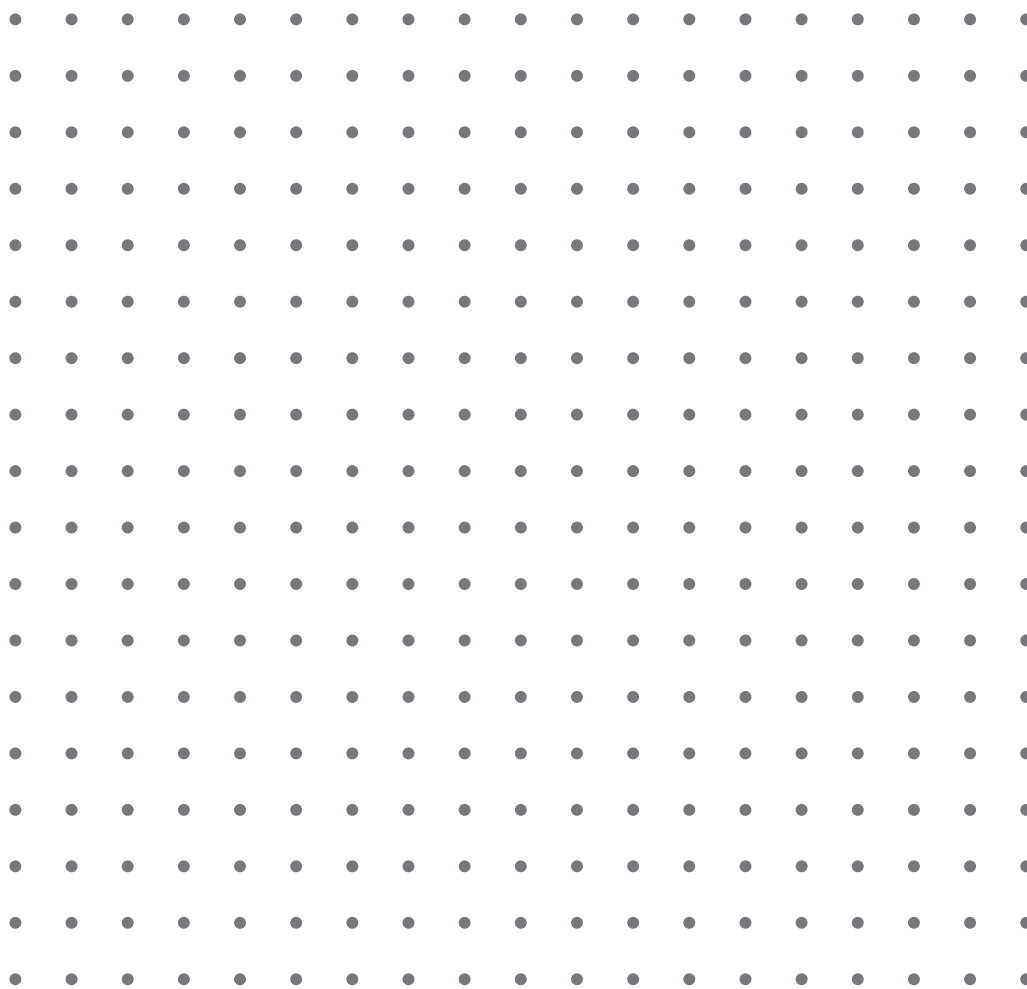
 Draw7 Discuss 

What strategy did you use to draw your second shape in Problems 5 and 6?

Summary 7.07

When comparing the perimeter of shapes, it is important to measure the length of each side. 2 shapes that look different can have the same perimeter if the total length of their sides is the same.

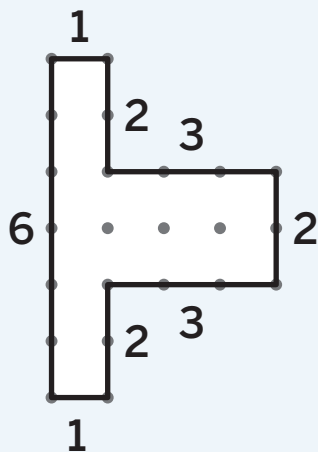

$$1 + 1 + 2 + 2 + 2 + 3 + 3 + 6 = 20 \text{ units}$$

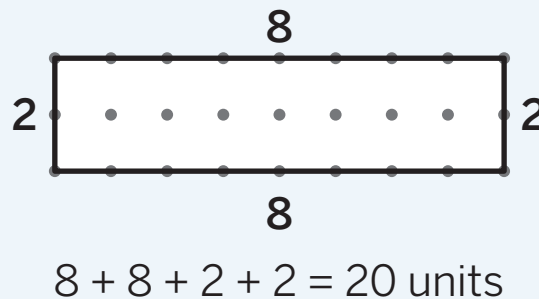

Practice 7.07

- 1 Draw 2 different shapes with a perimeter of 18 units.

 Draw

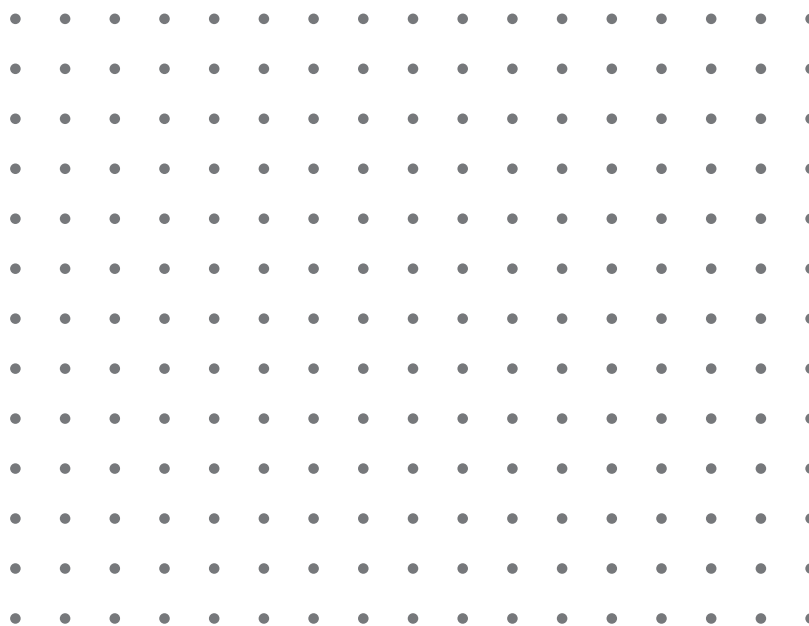

Use the information for Problems 2 and 3.

Clare wants to install a garden with a perimeter of 16 units.

- 2** Draw as many different possible shapes Clare could use for her garden.

 Draw

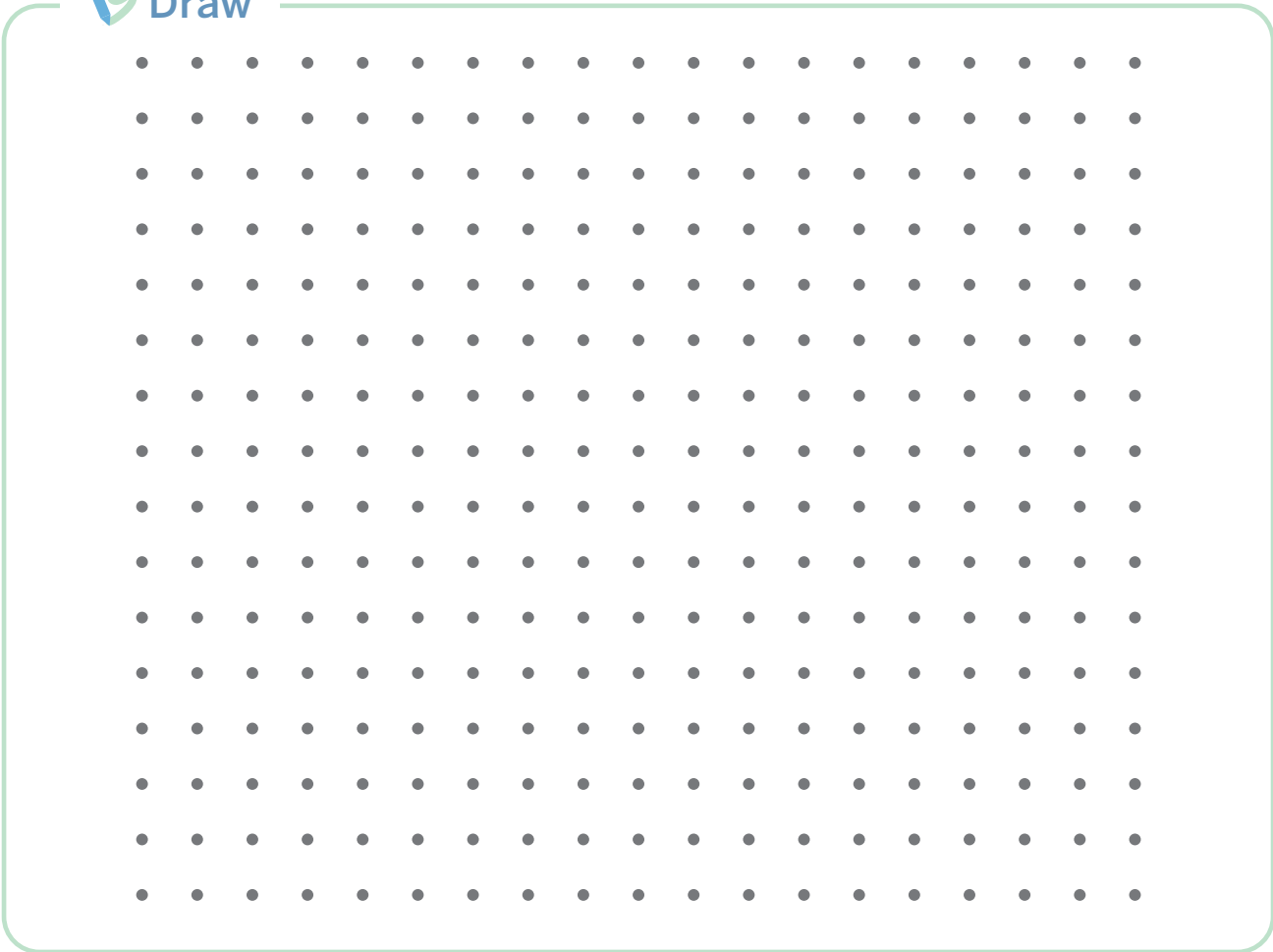

- 3** Could Clare use this shape? Explain your thinking.

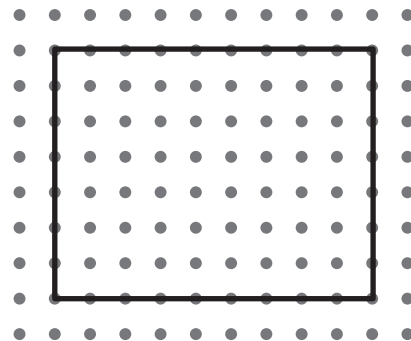

4  Select *all* the shapes with a perimeter of 30 units.

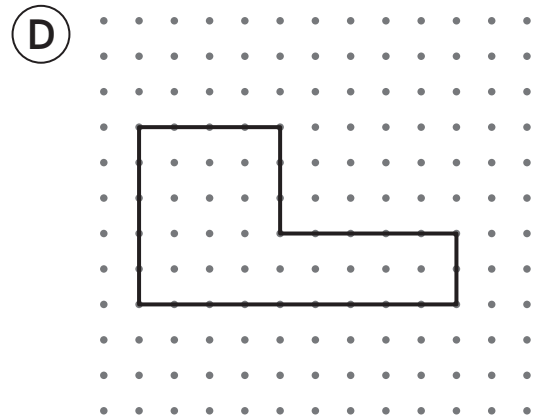
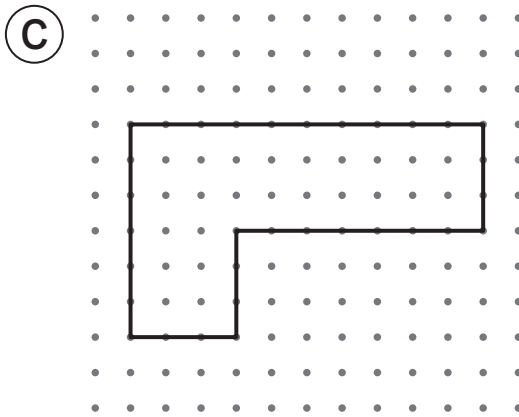
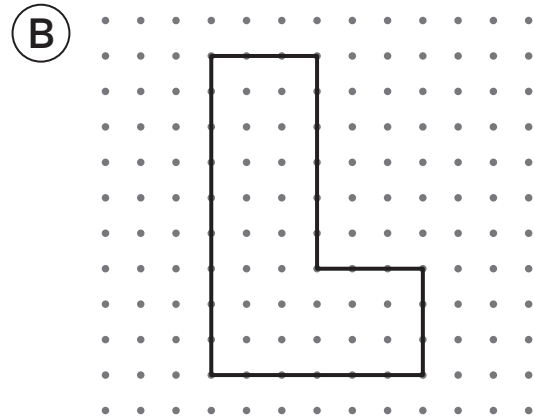
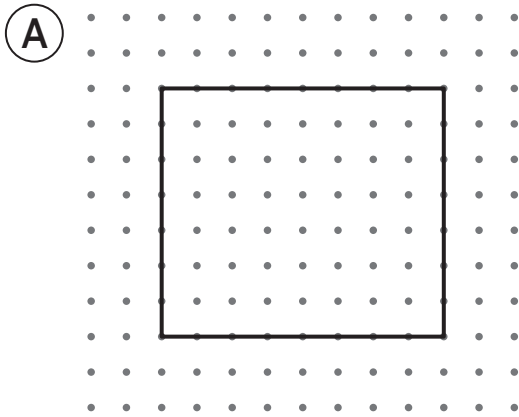

Spiral Review

For Problems 5–12, determine the value of the expression.

5 $15 \div 5$ _____

6 9×6 _____

7 3×9 _____

8 $16 \div 8$ _____

9 $30 \div 6$ _____

10 4×8 _____

11 $40 \div 5$ _____

12 7×7 _____

Fencing the Field

Let's determine the perimeters of shapes.



Warm-Up

1

eyes on teacher

I can be all of me in math class.

Piho observed shapes around the world. What shapes do you observe in your community?

Activity

1

Perimeters of Shapes

Determine the perimeter of each shape.

Show or explain your thinking.

2

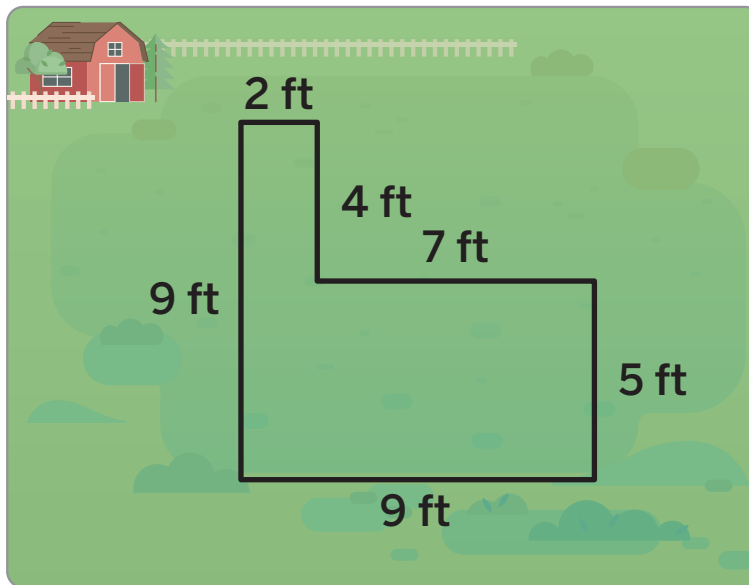

answer: _____

1**Perimeters of Shapes (continued)**

Show or explain your thinking.

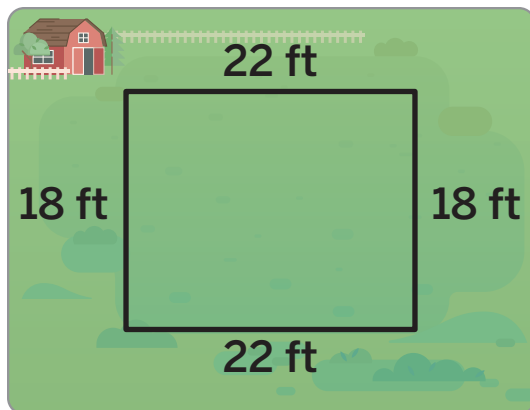
3

answer: _____

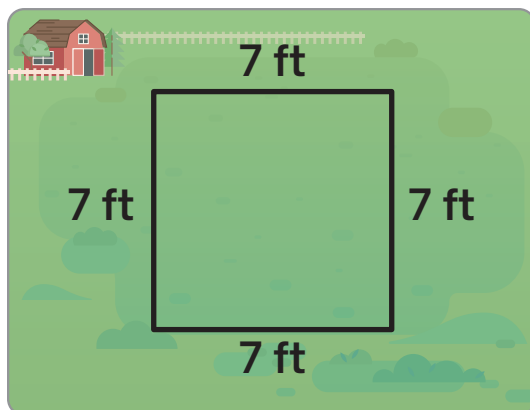
4

answer: _____

4**Discuss**

How did you determine the perimeter?

Something Is Missing

- 5** Determine the perimeter of the shape.

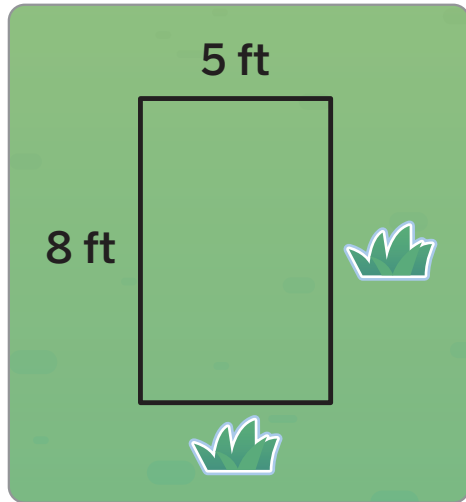

answer: _____

- 5** Discuss 

How did you determine the perimeter?

- 6** Info Gap: You and your partner will be given a set of shapes with labeled side lengths.

1. Look at your card, but do not show it to your partner.
2. **Partner 1:** Ask your partner, “Which side length would you like to know for Shape A?”
3. **Partner 2:** If you need more information to determine the perimeter, repeat Step 2.
4. If you do not need another clue, determine the perimeter.
5. Switch roles and repeat for Shapes B–F, switching roles after each problem.

Something Is Missing (continued)

- 6** Determine the perimeter of each shape using the Info Gap routine.



answer: _____

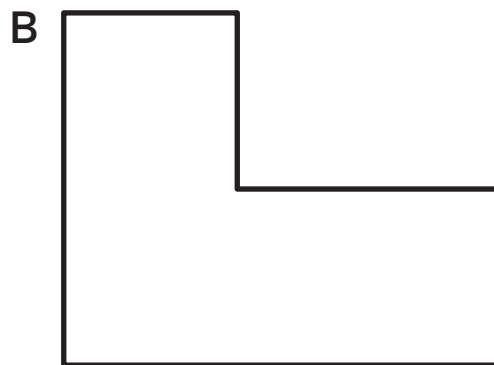

answer: _____

C This is a square.

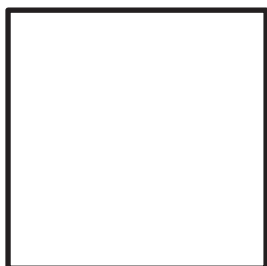

answer: _____

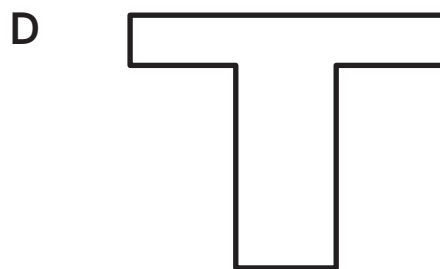

answer: _____



answer: _____



answer: _____

- 7** Let's discuss Diego's work.

Summary 7.08

You can use what you know about a shape's attributes to determine unknown side lengths. You can use multiplication to calculate the perimeter by grouping sides with the same length.

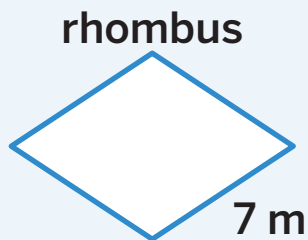

A rhombus has 4 equal sides.
So, each side is 7 meters long.

$$4 \times 7 = 28$$

The perimeter is 28 meters.

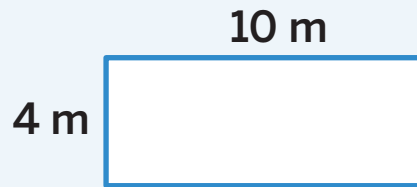

Opposite sides of a rectangle are equal. So, two sides are 4 meters long and two sides are 10 meters long.

$$4 + 4 + 10 + 10 = 28$$

The perimeter is 28 meters.

Practice 7.08

For Problems 1–3, determine the perimeter of the shape.

 Show your thinking.

1

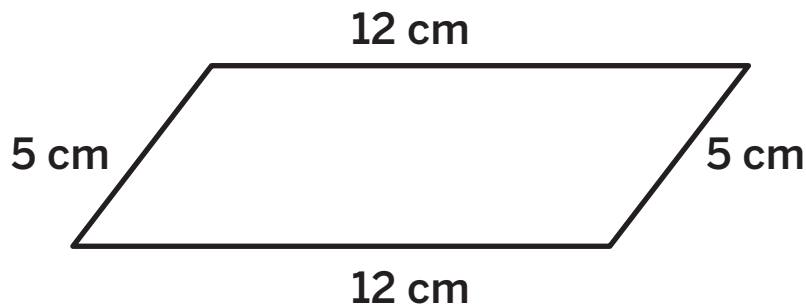

answer: _____

2

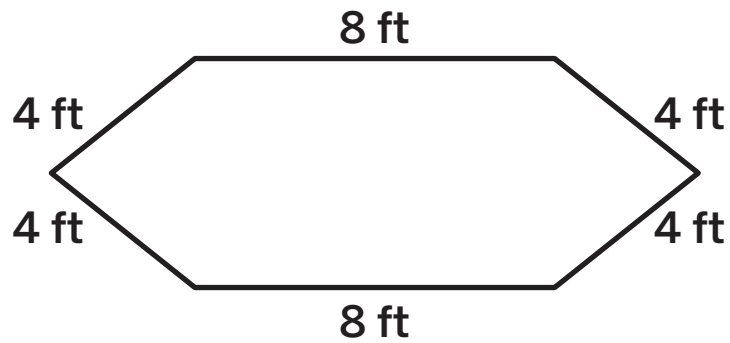

answer: _____

3

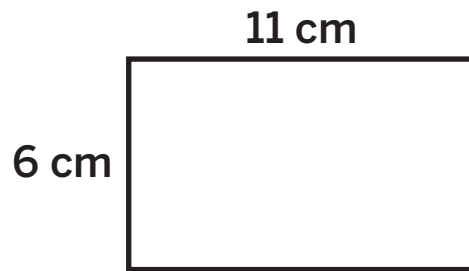

answer: _____

4

 All sides of the shape have the same length. What is the perimeter of the shape?

- (A) 11 centimeters
- (B) 24 centimeters
- (C) 30 centimeters
- (D) 36 centimeters

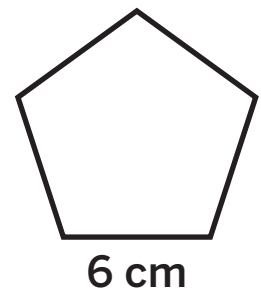

Spiral Review

5 Determine the sum of 358 and 162.

 Show your thinking.

answer: _____

For Problems 6–13, determine the value of the expression.

6 2×4 _____

7 7×6 _____

8 5×6 _____

9 3×4 _____

10 $16 \div 4$ _____

11 $27 \div 3$ _____

12 $72 \div 9$ _____

13 $50 \div 5$ _____

Solving Perimeter Problems

Let's solve problems that involve perimeter.

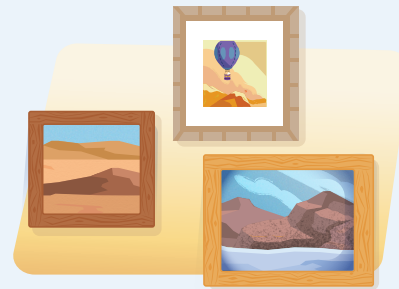

Warm-Up



eyes on teacher



We are a math community.

How do you support your classmates as math thinkers and problem solvers?

Activity

1

Missing Measurements

Determine the lengths of the unlabeled sides. Add the labels to the diagrams.



Show or explain your thinking.

- 1 The pentagon has a perimeter of 32 centimeters.

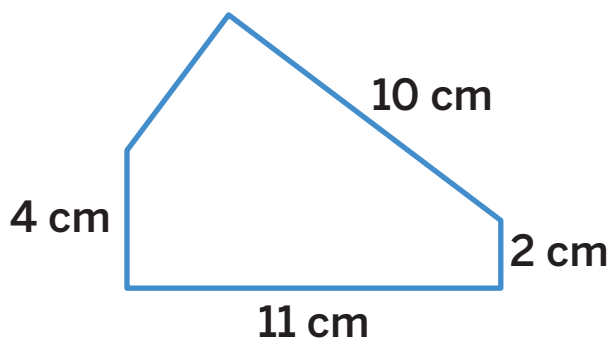

1**Missing Measurements (continued)****Show or explain your thinking.****2**

The rectangle has a perimeter of 56 feet.

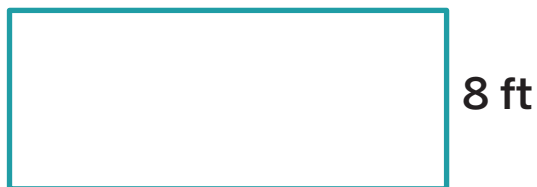
**3**

The pentagon has 5 equal sides and a perimeter of 65 inches.

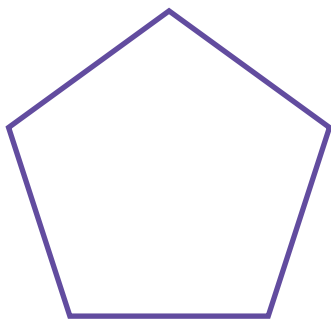
**4****Discuss**

Choose 1 shape. Explain how you determined the unknown side lengths.

2

More Missing Measurements

After returning home from her travels, Piho drew pictures of some of the places she visited to remember her travels. For each picture, she built a frame to keep the pictures safe. Help Piho build her frames by representing and solving each problem.

- 5 For her drawing of the Angkor Wat temple in Cambodia, Piho glued pieces of wood together to create a 36-centimeter by 21-centimeter rectangular frame. What is the total length of wood Piho used to build the frame?

 Show or explain your thinking.

answer: _____

More Missing Measurements (continued)

- 6 To remember her trip to Antarctica, Piho wanted a frame for her picture of Scott's Hut. Piho had 38 inches of wood to create a rectangular frame. She cut 2 sides of the frame that each had a length of 7 inches. She then used the rest of the wood to cut the remaining 2 sides of the frame. What is the length of each remaining side?

 Show or explain your thinking.

answer: _____

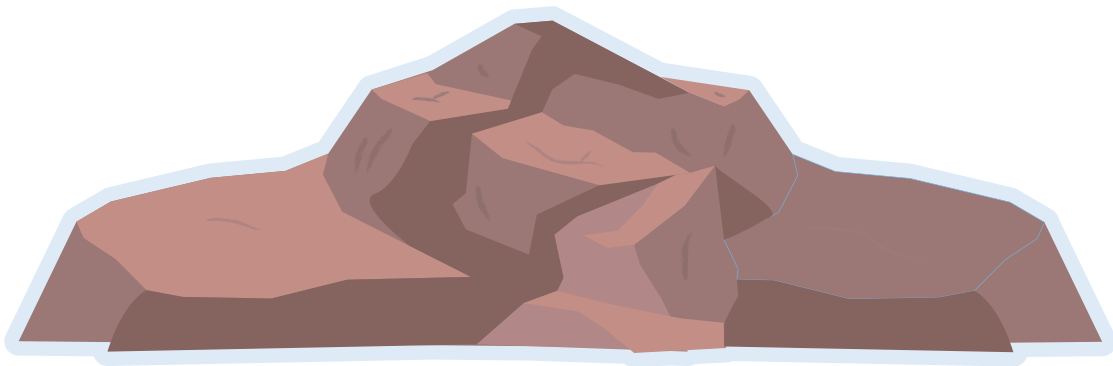

Summary 7.09

You can determine a shape's unknown side lengths if you know the perimeter, some of the side lengths, and the shape's defining attributes.

The perimeter of the rectangle is 24 feet.

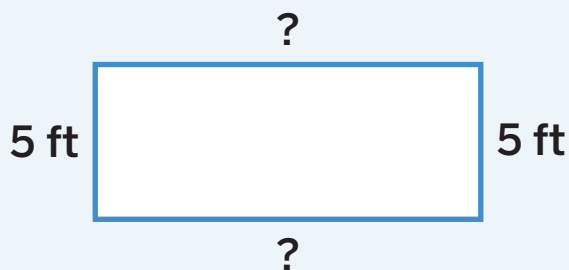

$$2 \times 5 = 10$$

$$24 - 10 = 14$$

$$2 \times ? = 14$$

$$? = 7$$

Practice 7.09

- 1 Priya has a square flower garden in her yard. The border around the garden is 32 feet long. How long is each side of her flower garden?

 Show or explain your thinking.

answer: _____

- 2 The hexagon has 6 equal-length sides and a perimeter of 96 centimeters. What is the length of each side?

i Show or explain your thinking.

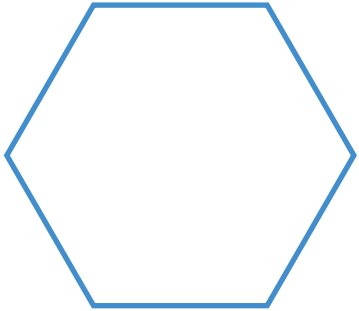

answer: _____

- 3 A rectangle has a perimeter of 50 inches. Determine the lengths of the unlabeled sides. Add the labels to the rectangle.

i Show or explain your thinking.

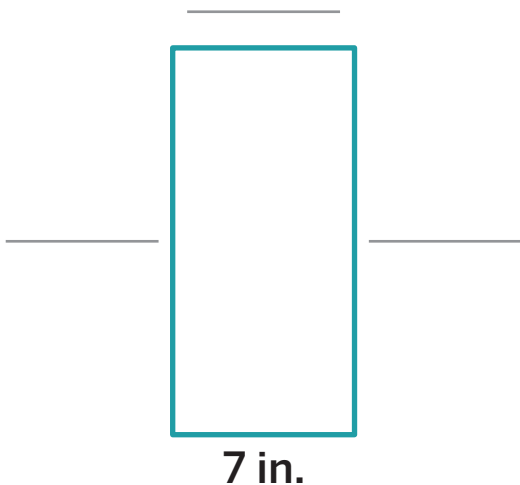



Notes:

Expanding on Perimeter

✦ Unit Story: Through Piho's Eyes



SKYEX DRONE/Shutterstock.com

When Piho returned to Greenland, she saw her home from a new perspective.

When have you looked at a math concept from a new or different perspective?

In the Real World

Let's solve problems involving the perimeter and area of rectangles.

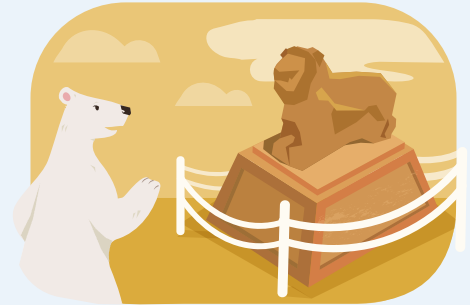

Warm-Up



eyes on teacher



We are a math community.

How can listening to others' viewpoints help our community of math learners?

Activity

1

The Lion Sculpture

During one of her stops, Piho visited a sculpture of a lion. The sculpture was on a rectangle of stone that was surrounded by a rope barrier. One side of the rectangle measured 20 meters. Another side measured 8 meters.

- 1 What is the total length of the rope barrier around the lion sculpture?



Show or explain your thinking.

answer: _____

1**The Lion Sculpture (continued)**

- 2 What is the area in square meters of the rectangle stone the lion sculpture sits on?

 Show or explain your thinking.

answer: _____



Info Gap: A Carpet and a Mural

Hands-On

Your group will be given a set of clues about a carpet and a mural.

1. Place all the mural cards facedown in a pile.
2. Divide the carpet cards among your group members. Look at your cards, but do not show them to your group.
3. The person holding Carpet clue 1:
 - Read the information on the card. Then place the card faceup in front of the group.
 - Ask the group, “How can the information on the card help us solve the problem? Do we need another clue?”
4. If your group does not need another clue, solve the problem.
5. If your group needs more information to solve the problem, repeat Step 3 with each card in numerical order until you have enough information to solve the problem or all the cards have been read aloud.
6. Repeat Steps 2–5 with the mural cards.

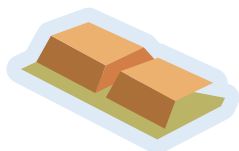

Info Gap: A Carpet and a Mural (continued)

- 3 Use the carpet clues to determine the perimeter of the carpet.

 Show or explain your thinking.

answer: _____

- 4 Use the mural clues to determine the area of the mural.

 Show or explain your thinking.

answer: _____

Summary 7.10

Perimeter and area are measurable attributes of rectangles. Perimeter is the total length of the boundary of a rectangle. Area is the number of square units that cover a rectangle.

A shop owner is hanging lights around the front window of her store.

The total amount of glass covering the window represents the **area** of the window.

$$5 \times 5 = 25, \text{ so} \\ 25 \text{ square feet}$$

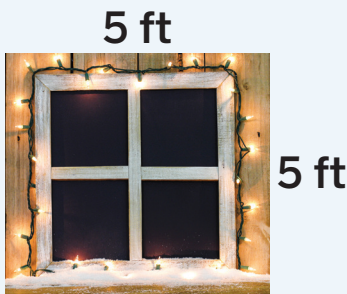

laura.h/Shutterstock.com

The total length of hanging lights represents the **perimeter** of the window.

$$5 + 5 + 5 + 5 = 20, \text{ so} \\ 20 \text{ feet}$$

Practice 7.10

- 1 Identify whether each of the expressions could represent the area of a garden that measures 36 square feet.

	Yes	No
9×4		
$6 + 6 + 6 + 6$		
$(9 \times 2) + (4 \times 2)$		
6×6		
6×9		
2×18		

- 2 A bedroom has a length of 14 feet and a width of 12 feet. Select *all* the expressions that could represent the perimeter of the bedroom.

- (A) 12×14 (B) $12 + 12 + 14 + 14$
(C) $(12 \times 2) + (14 \times 2)$ (D) $(2 \times 7) + (2 \times 6)$
(E) $12 + 14$ (F) $(2 \times 14) + (2 \times 12)$

- 3**  One side of a rectangular garage measures 9 feet. Another side measures 11 feet. What is the area of the garage in square feet?

_____ square feet

Use the information for Problems 4 and 5.

**A rectangular library table has an area of 60 square feet.
The long side of the table measures 10 feet.**

 **Show or explain your thinking.**

- 4** Determine the length of the short side of the table.

answer: _____

- 5** Determine the perimeter of the table.

answer: _____

Spiral Review

For Problems 6–10, complete the statement using $<$, $>$, or $=$.

6 $\frac{3}{8}$ _____ $\frac{3}{6}$

7 $\frac{9}{10}$ _____ $\frac{9}{3}$

8 $\frac{4}{5}$ _____ $\frac{2}{5}$

9 $\frac{9}{10}$ _____ $\frac{11}{10}$

10 $\frac{4}{3}$ _____ $\frac{3}{4}$

For Problems 8–15, determine the value of the expression.

11 $40 \div 8$ _____

12 $33 \div 3$ _____

13 $48 \div 12$ _____

14 $12 \div 2$ _____

15 10×9 _____

16 8×6 _____

17 6×3 _____

18 3×3 _____

Perimeters and Areas

Let's explore the perimeters and areas of rectangles.

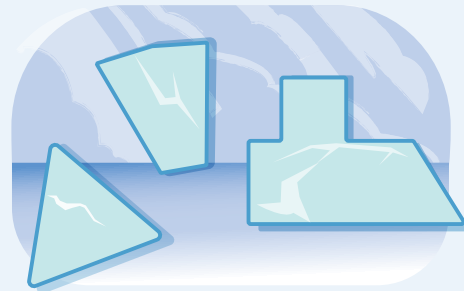

Warm-Up



eyes on teacher



We are a math community.

How do you use the space around you to help everyone do their best work?

Activity

1

More Rectangles

Determine the perimeter and area of each rectangle.

Show your thinking.

1

5 cm

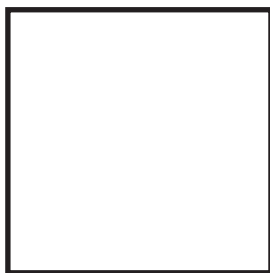

5 cm

perimeter: _____

area: _____

1**More Rectangles (continued)**

Determine the perimeter and area of each rectangle.

 Show your thinking.

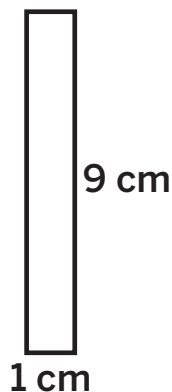
2

perimeter: _____

area: _____

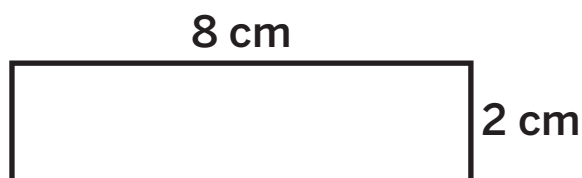
3

perimeter: _____

area: _____

4**Discuss** 

What do you notice about the perimeters and areas of the rectangles?

A Perimeter of 16

Draw 3 different rectangles with a perimeter of 16. Label the side lengths of each rectangle. Then determine each area.

 Draw

5 Rectangle 1

area: _____

6 Rectangle 2

area: _____

A Perimeter of 16 (continued) Draw

7 Rectangle 3

area: _____

8 Discuss 

Is the class conjecture you made true? How do you know? Are there any examples that show your conjecture is false?

Summary 7.11

Rectangles with the same perimeter can have different areas.

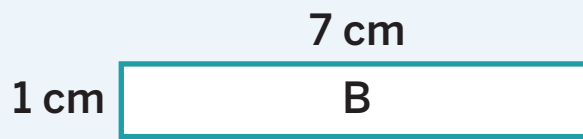
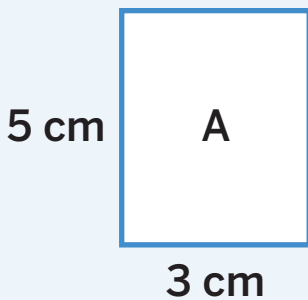

Perimeter of Rectangle A: 16 cm

Perimeter of Rectangle B: 16 cm

Area of Rectangle A: 15 square centimeters

Area of Rectangle B: 7 square centimeters

Practice 7.11

- 1 Draw 2 rectangles with a perimeter of 24 units but different areas.

 Draw

A large, empty rounded rectangle with a light green border, intended for drawing two rectangles with a perimeter of 24 units but different areas.

Practice 7.11

Name _____ Date _____

- 2 Draw 2 different rectangles with a perimeter of 18 units. Then write the area inside the rectangle.

 Draw

For Problems 3–5, determine the perimeter and area of the rectangle.

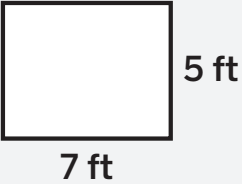
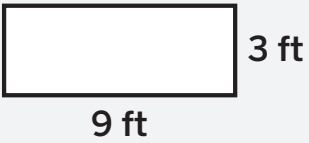
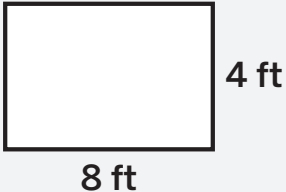
		Perimeter	Area
3			
4			
5			

6 Which 2 rectangles have the same perimeter?

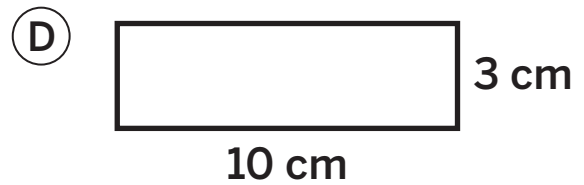
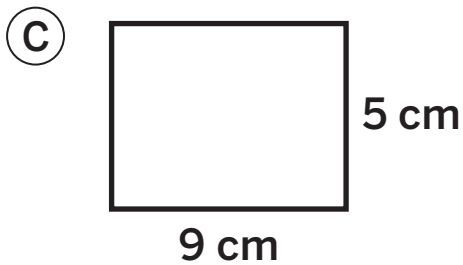
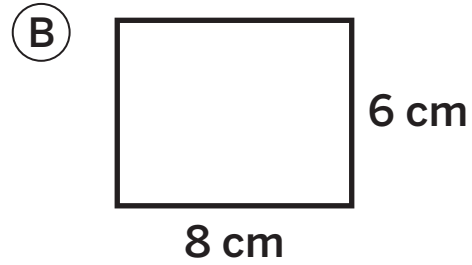
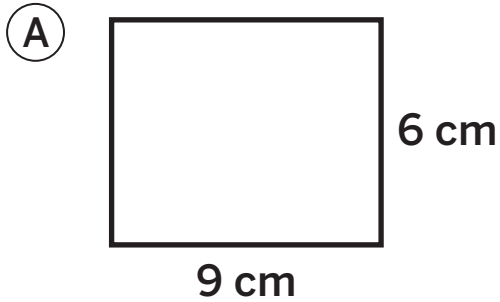

Spiral Review

For Problems 7 and 8, evaluate the expression.

 Show or explain your thinking.

7 $828 + 84$

answer: _____

8 $828 - 84$

answer: _____

For Problems 9–12, determine the value of the expression.

9 7×12 _____

10 $56 \div 8$ _____

11 4×5 _____

12 $24 \div 2$ _____

Unique Unicorns

Let's create different rectangles with the same area.

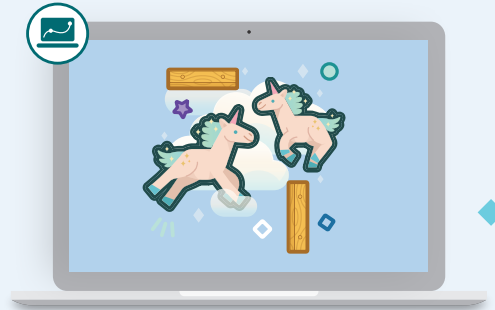

Warm-Up

1

eyes on teacher

I am a doer of math.

Why might it be helpful to share a mathematical idea even if you are not sure that it will work?

Activity

1

Magical Meadow

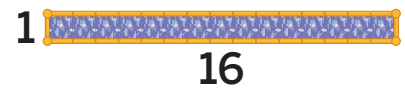

2

Create 2 different rectangle pens that each have an area of 16 square units.

Draw

2

Justify

How do you know your rectangles are different from the given rectangle?

1**Magical Meadow (continued)**

- 3** Create 2 different rectangle pens that each have an area of 12 square units.



 Draw



- 4** Let's compare rectangle pens.

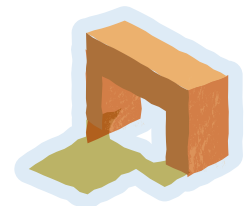

2

All the Ways

- 5** Create as many rectangle pens as you can with an area of 20 square units. Represent each pen with a multiplication expression. Draw rectangles if it is helpful.

Expressions



Summary 7.12

Rectangles with the same area can have different perimeters.

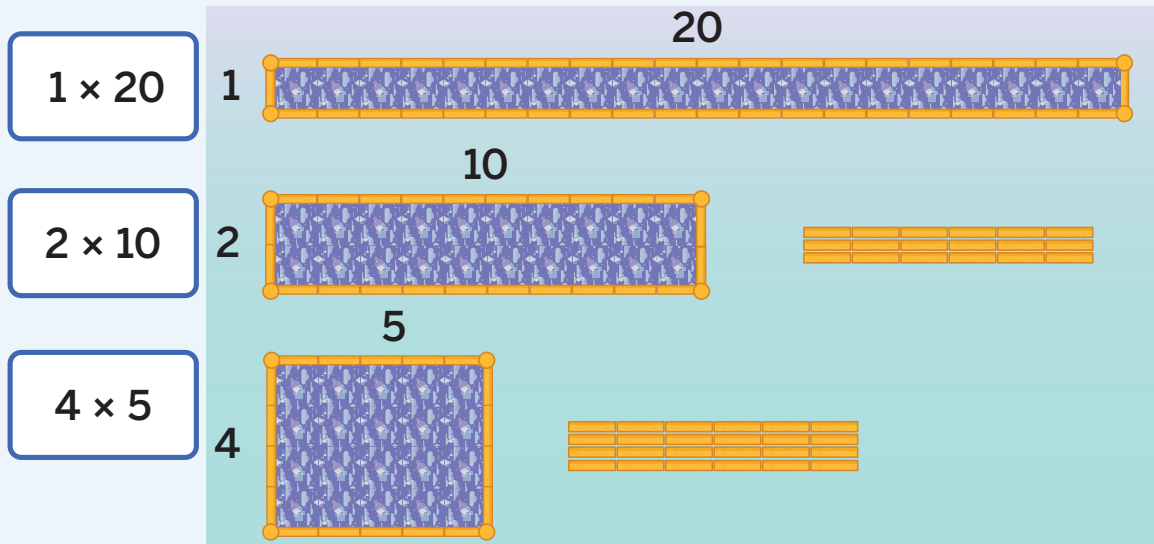

Practice 7.12

- 1 Draw 2 rectangles that have an area of 36 square units and different perimeters.

 Draw

A large grid of 20 columns and 15 rows of dots, intended for drawing rectangles with an area of 36 square units.

Practice 7.12



Name _____ Date _____

- 2 Draw 2 different rectangles that have an area of 18 square units. Then write the perimeter inside the rectangle.

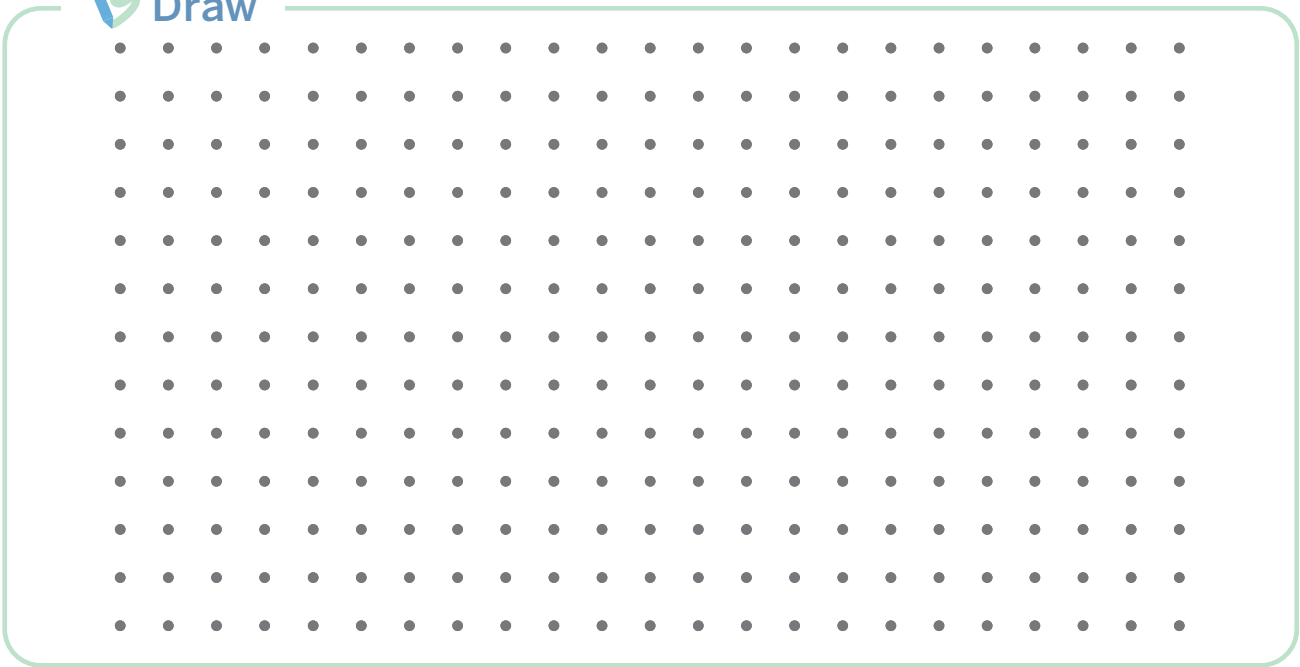
 Draw



For Problems 3–5, determine the perimeter and area of the rectangle.

		Perimeter	Area
3	 6 ft 5 ft		
4	 15 ft 2 ft		
5	 10 ft 3 ft		

Practice 7.12

Name _____ Date _____

6  Select 2 rectangles that have the same area and different perimeters.

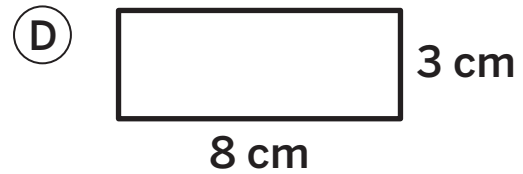
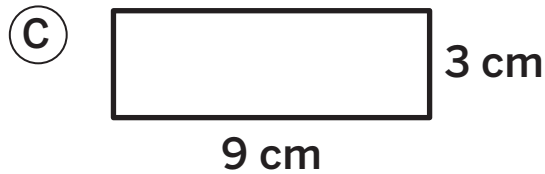
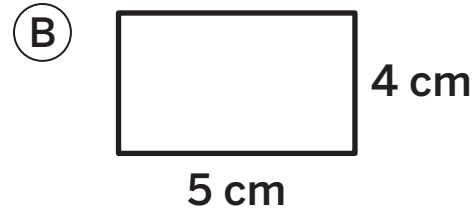
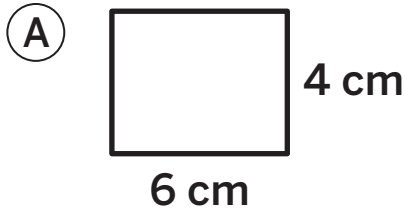

Spiral Review

For Problems 7 and 8, evaluate the expression.

 Show or explain your thinking.

7 $209 + 623$

answer: _____

8 $623 - 209$

answer: _____

For Problems 9–12, determine the value of the expression.

9 9×5 _____

10 6×6 _____

11 $81 \div 9$ _____

12 $15 \div 3$ _____

Designing a Tiny House

Let's apply what we know about area and perimeter to design a tiny house.

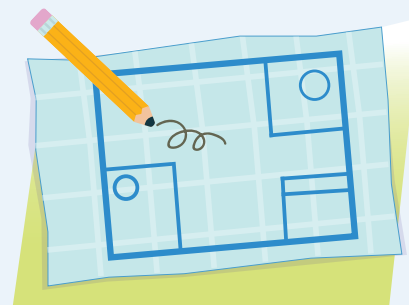

Warm-Up



eyes on teacher



I can be all of me in math class.

Piho realizes that her home is special. What makes you proud of the place where you live?

Activity

1

Mini Mansion

You will be given a handout.

1 Create a design for your tiny house. Your house must include:

- A bedroom and a living room with the same area but different perimeters
- A bed with a side length of 6 feet in the bedroom
- A kitchen that is *not* a quadrilateral, and *includes*:
 - Countertops with a perimeter of 12 feet in the kitchen
 - A fridge that is 2 feet wide by 2 feet long
- A square bathroom
- A couch with an area of 15 square feet in the living room

Use the grid in your handout to create your final design.

1**Mini Mansion (continued)**

- 2** Record the perimeter and area of each feature that is listed.

Feature	Perimeter	Area
bedroom		
bed		
kitchen		
fridge		
countertops		
bathroom		
living room		
couch		

- 3** **Discuss** 

How did you decide where and how to place the couch, bed, and fridge in your tiny house?

Summary 7.13

Perimeter and area are important measurements to consider when designing spaces.

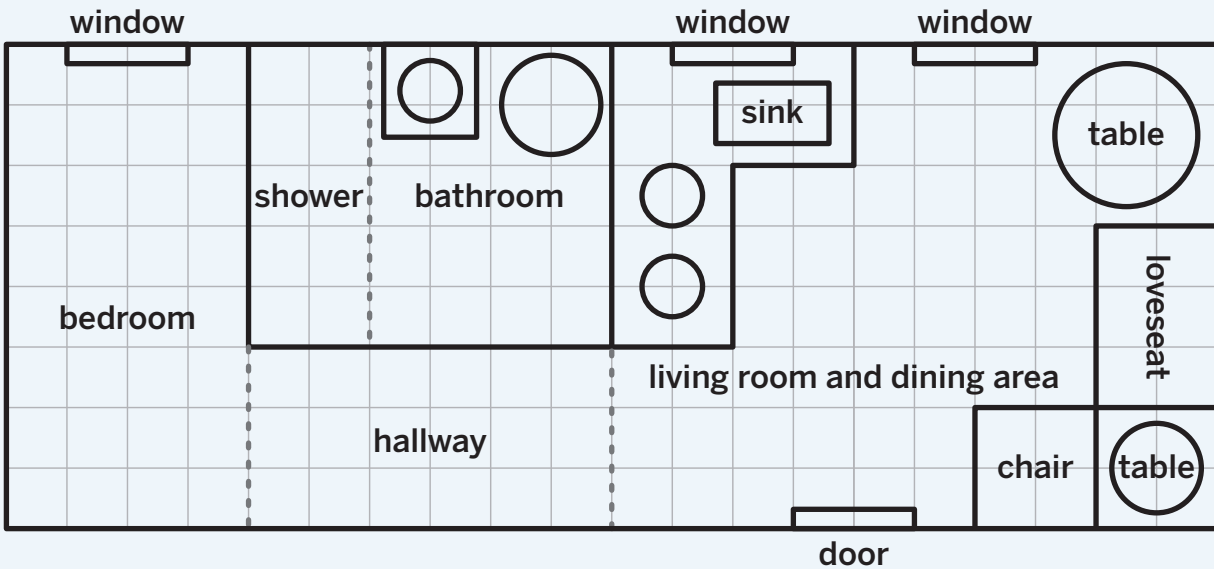

Practice 7.13

Use the design of the tiny house for Problems 1 and 2.

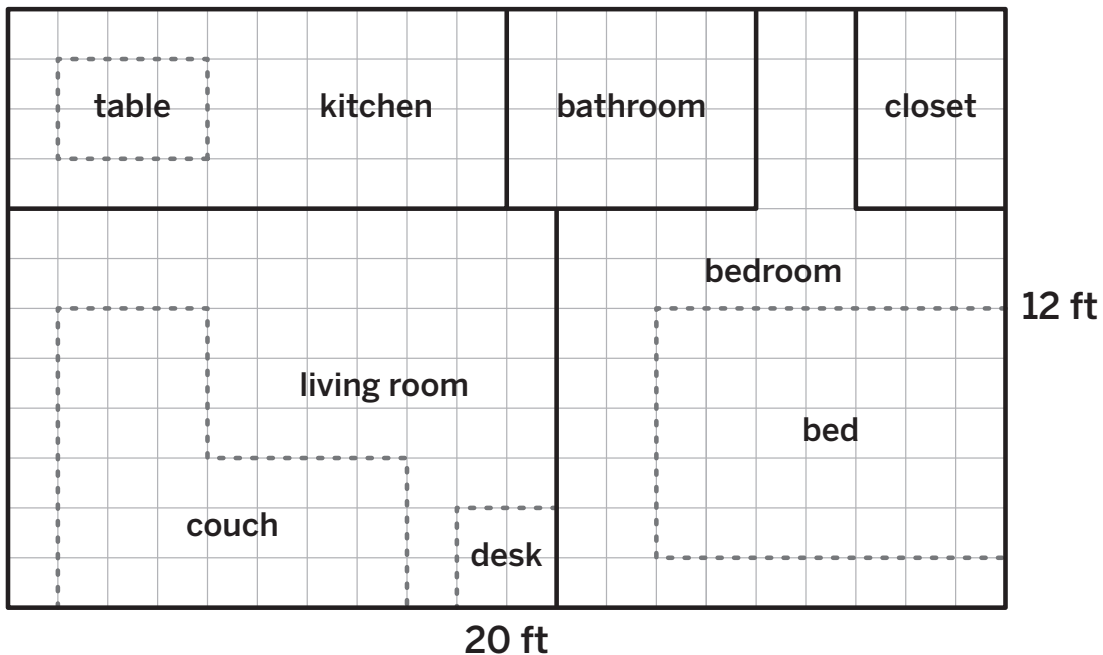

- 1 Record the perimeter and area of each feature.

Feature	Perimeter	Area
table		
kitchen		
couch		
living room		
desk		
bathroom		
closet		
bedroom		
bed		

- 2  Which of the following statements are true? Select *all* that apply.

- (A) The area of the bathroom is greater than the area of the closet.
- (B) The perimeter of the living room is greater than the area of the living room.
- (C) The area of the bed is smaller than the perimeter of the couch.
- (D) The perimeter of the bed is smaller than the perimeter of the couch.

Spiral Review

For Problems 3–6, match the unit fraction with an equivalent non-unit fraction.

Unit fraction

Non-unit fraction

3

$\frac{1}{2}$

_____ $\frac{2}{10}$

4

$\frac{1}{4}$

_____ $\frac{2}{6}$

5

$\frac{1}{5}$

_____ $\frac{2}{8}$

6

$\frac{1}{3}$

_____ $\frac{5}{10}$

For Problems 7–16, determine the value of the expression.

7

3×5 _____

8

$81 \div 9$ _____

9

6×5 _____

10

$54 \div 9$ _____

11

8×4 _____

12

$56 \div 7$ _____

13

7×9 _____

14

$35 \div 7$ _____

15

8×7 _____

16

$65 \div 5$ _____

Math at Work

What is a city, state, or country you have traveled to or would like to travel to? Why would you choose that place?

Travel agents help people plan trips around the world. They might use shapes to describe interesting places for tourists to visit. They might use perimeter or area to show how far a tourist might need to walk from one place to another.



TetianaKtv/Shutterstock.com.
Inspiration GP/Shutterstock.com.

Math in the World

Many buildings in Strasbourg, France are decorated in patterns that use different shapes. What shapes are on this building? How can you describe them?



SvetlanaSF/Shutterstock.com.

Math Mindset

Do all rectangles with the same perimeter also have the same area?
Why or why not?